



CREASHADE
SUN SHADING SOLUTIONS



Creating healthy spaces



Louvre panels & grilles

Contents

INTRODUCTION

Contents	2
RENSON® Corporate Identity	3
General	4
Definitions	5
Louvre selector guide	6
Watertightness tests (HEVAC-test)	8
Service	10
Options	11

BUILT-IN WALL LOUVRES ALUMINIUM

411	Wall louvre, standard series, pitch 33	12
412	Wall louvre with chevron section blades, pitch 20	14
421	Wall louvre, heavy-duty series, pitch 50	15
422	Wall louvre with chevron section blades, heavy-duty series, pitch 33	16
425	Wall louvre, extra-heavy-duty series	17
427	Wall louvre, extra-heavy-duty series, with adjustable blades	18
451	Wall louvre, heavy-duty series, pitch 66	20
452	Wall louvre, heavy-duty series with chevron section blades, pitch 66	21
452V	Wall louvre, heavy-duty series with vertical chevron section blades, pitch 66	21
453	Wall louvre, heavy-duty series, with aluminium coil blades, pitch 65	22
480	High-airflow wall louvres, pitch 60	23
481	Wall louvre, heavy-duty series, pitch 50	24
491	"Storm" wall louvre, pitch 33	25
511	Wall louvre, galvanised steel, pitch 34	26
521	Wall louvre, heavy-duty series, galvanised steel, pitch 50	27
621	Wall louvre, stainless steel, pitch 50	28

SURFACE-MOUNTED LOUVRES ALUMINIUM

431	Surface-mounted wall louvre, pitch 33	29
432	Surface-mounted, glazed-in louvre with frame	31
433	Pressure-relief damper	32

GLAZED-IN LOUVRES ALUMINIUM

414	Glazed-in louvre, pitch 33	33
414VA	Controllable louvre	35
414THF	Thermally insulated window grille	36
415	Glazed-in louvre with chevron section blades, pitch 20	37
415VA	Controllable louvre with chevron section blade	38
424	Glazed-in louvre, heavy-duty series, pitch 50	39
428	Glazed-in louvre with chevron section blades, heavy-duty series, pitch 95	40
483	High-airflow glazed-in louvre, pitch 60	41
484	Glazed-in louvre, heavy-duty series, pitch 50	42
494	Glazed-in louvre, heavy-duty series, pitch 50	43
425GL	Glazed-in louvre, extra-heavy-duty series	44
427GL	Glazed-in louvre with adjustable blades, extra-heavy-duty series	45

ACOUSTIC LOUVRES ALUMINIUM

445/86	Acoustic wall louvre	46
446/150	Acoustic wall louvre	48

446/225	Acoustic wall louvre	48
446/300	Acoustic wall louvre	48
447/150	Acoustic wall louvre	50
447/225	Acoustic wall louvre	50
468AK/1	Interior acoustic wall louvre	52

BURGLARPROOF LOUVRES ALUMINIUM

421WK2	Buglarproof louvre class WK2	53
431WK2	Buglarproof louvre class WK2	54
423	Buglarproof louvre class WK4	55

LOUVRE BOX ALUMINIUM

440	Turret	56
-----	--------	----

CONTROLLABLE CAVITY WALL LOUVRES ALUMINIUM

442	Cavity wall ventilator	57
441	Register with frame	58
4032	Register to fix	59
XD	Controllable internal louvres	60

CIRCULAR PUNCHED GRILLES ALUMINIUM

435R	Circular built-in punched grille	61
436	Punched grille	62

VENTILATION GRILLES ALUMINIUM

381	Built-in ventilation grille	63
-----	-----------------------------	----

FLOOR GRILLES ALUMINIUM

311	Convactor grille	64
371	Floor grille, heavy-duty series	65

LINEAR BAR GRILLES ALUMINIUM

392	Linear bar grille	66
394	Linear bar grille for self-assembly	67

DOOR GRILLES ALUMINIUM

461	Door grille	68
461AK Silendo®	Acoustic door grille for residential sector	69
Invisido® 469	Acoustic door grille for residential sector	70
468AK/2	Acoustic door grille	71

FIRE-RESISTANT LOUVRES

Incendo® 464	Fire-resistant louvre with angled blades	72
465	Fire-resistant louvre with angled blades	73
466	Fire-resistant louvre with horizontal blades	74

ROUND LOUVRES ALUMINIUM

411R	Round wall louvre	76
412R	Round wall louvre with chevron section blades	77
421R	Round wall louvre, heavy-duty series	78
431R	Round louvre without frame	79
414R	Round glazed-in louvre	80
415R	Round louvre with chevron section blade	81

References	82
------------	----

Why choose Renson® louvres?

- Renson® innovates. Having an in-house R&D team
- Renson® widens. Offering the widest range of louvres
- Renson® integrates. through vertical integration
- Renson® specializes. Since 1909 and is represented worldwide

The acoustic properties of the Renson®-blades have been tested by the internationally recognized laboratory, IFT Lab Rosenheim (Germany)

Water resistance tested by BSRIA laboratories.





Material

All louvres in this brochure have been manufactured from aluminium-profiles **AlMgSi 0,5** (according EN 12020-2).

Light, strong & durable

Aluminium is a very light metal, about one third of the weight of steel. This evolves in a lighter product, more efficient use of transport, high loading capacity, lower material usage...

Anti-corrosion

The finished aluminium louvre is very rust and corrosion persistent. In order to improve this persistency, the louvre can be anodized or powder-coated. On top of that, aluminium is UV- resistant and can easily handle fluctuation in temperature.

100% recyclable

Aluminium is 100% recyclable without loss of quality. The energy used to fuse the product takes only about 5% of the energy used to produce the original product. Did you know that 75% of the produced aluminium is still circulating the world?



Finishing

Anodized in satin/bronze colour (20 micron) or powder-coated in any RAL or Syntha Pulvin colour (40 micron).

Maintenance

The only maintenance required is cleaning of the louvre.

Warranty

Renson Ventilation nv provides a 10 year warranty on the aluminium parts of the product related to mechanical strength and colour. A 5 year warranty is applicable on the gloss of the powder-coated profiles and the rubber & synthetic elements.

Packing

Louvres will be packed in a transparent plastic foil. In case the louvre is larger than 500 mm on one side, expanded polystyrene will be added on the framework as protection. For very large louvres, an additional carton packaging ensures the right protection.



Geometric terms for louvres

Visual free area = determined by the ratio between the visual distance between two blades (A) and the blade pitch (C).

Physical free area = determined by the ratio between the smallest gap between two blades (B) and the blade pitch (C). Owing to peripheral effects and assembly, a maximum deviation of 5% must be considered.

Remark: The top and bottom blades are not taken into account in the two free area definitions.

All louvre characteristics can be calculated making use of free software available on the website <http://uk.renson.eu/industrial-louvres-UK.html>

Airflow

K-factor = a value describing aerodynamic resistance to airflow. Contrary to the free area, this value describes the link between the airflow through the louvre and the pressure drop over it.

C_e = entry loss coefficient = a value describing the aerodynamic channelling of the airflow on entry. This value represents the ratio between the actual airflow compared with the theoretical airflow.

C_d = discharge loss coefficient = a value describing the aerodynamic channelling of the airflow on discharge. This value represents the ratio between the actual airflow compared with the theoretical airflow.

Acoustic terms

dB(a) = the decibel (dB) in this brochure is used to characterize the noise reduction of a louvre. The A-weight (dB(a)) shows that the acoustic tests have been taken out according to the sensitivity of the human sound spectrum.

$D_{n,e,w}$ = weighted, element-normalized sound level difference, used to characterise a single element like louvres.

R_w (C;Ctr) = weighted sound reduction index, used to characterise glazing, brick walls, wall louvres, etc.

C = *spectrum correction term* for pink noise, always added to R_w or $D_{n,e,w}$ when the source of the noise is, for example, fast-moving traffic.

C_{tr} = *spectrum correction term for traffic noise*, always added to R_w or $D_{n,e,w}$ when the source of the noise is, for example, urban traffic.

Frequency = pitch expressed in Hertz (Hz), or the number of vibrations per second.

IP-class = *international protection rating, protection rate to classify intruding objects and water penetration. Distance to the electrical installation is measured from the outside surface of the louvre.*

Remark: in order to select the correct louvre for your application please refer to local building regulations.

Building technical terms







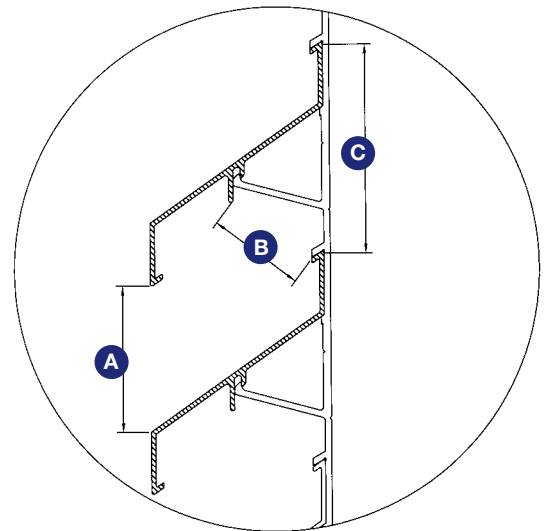



Wall anchor = aluminium bar used to mount and fix louvre to the wall.

Flange = part of the louvre visible on the front.

Aluminium extrusion = technique to shape an aluminium element by pressing it through a mold.





Family		Airflow								Page
Blade type Linus	Louvre type	Product type	Blade pitch	Physical free area	K-factor (supply)	K-factor (discharge)	Coeffi- cient C _e	Coeffi- cient C _d		
V20-blade	Built-in wall louvres	 412	20	39	33,8	33,8	0,172	0,172	14	
V20-blade	Built-in wall louvres	 412R	20	39	33,8	33,8	0,172	0,172	77	
V20-blade	Glazed-in louvres	 415	20	39	33,8	33,8	0,172	0,172	37	
V20-blade	Controllable glazed-in louvres	 415/VA	20	n.a.	n.a.	n.a.	n.a.	n.a.	38	
V20-blade	Round glazed-in louvres	 415R	20	39	33,8	33,8	0,172	0,172	81	
L.033.01	Built-in wall louvres	411	33,3	45	23,56	25,51	0,206	0,198	12	
L.033.07	Built-in wall louvres	411R	33,3	40,5	23,56	25,51	0,206	0,198	76	
L.033.01	Glazed-in louvres	414	33,3	45	23,56	25,51	0,206	0,198	33	
L.033.07	Round glazed-in louvre	414R	33,3	40,5	23,56	25,51	0,206	0,198	80	
L.033.01	Glazed-in louvres	414/D	33,3	n.a.	n.a.	n.a.	n.a.	n.a.	35	
L.033.01	Controllable glazed-in louvre	414/VA	33,3	n.a.	n.a.	n.a.	n.a.	n.a.	35	
L.033.01	Glazed-in louvres	414THF	33,3	n.a.	33,56	25,51	0,206	0,198	36	
L.033.01	Surface-mounted louvres	431	33,3	45	23,56	25,51	0,206	0,198	29	
L.033.01	Surface-mounted louvres	431R	33,3	45	23,56	25,51	0,206	0,198	79	
L.033.01	Controllable internal louvres	432	33,3	45	23,56	25,51	0,206	0,198	31	
L.033.01	Louvre box	440/11	33,3	45	23,56	25,51	0,206	0,198	56	
L.033.08	Built-in wall louvres	 491	33,3	26	123,5	118,1	0,09	0,092	25	
L.033.08	Glazed-in louvres	 494	33,3	26	123,5	118,1	0,09	0,092	43	
L.033V	Built-in wall louvres	422	33,3	43	61,04	61,04	0,128	0,128	16	
L.033V	Glazed-in louvres	428	33,3	43	61,04	61,04	0,128	0,128	40	
L.050.00	Built-in wall louvres	421	50	49	12,57	8,91	0,282	0,335	15	
L.050.00	Round built-in wall louvres	421R	50	47	12,57	8,91	0,282	0,335	78	
L.050.00	Louvre box	440/21	50	49	12,57	8,91	0,282	0,335	56	
L.050.00	Glazed-in louvres	424	50	49	12,57	8,91	0,282	0,335	39	
L.050HF	Built-in wall louvres	481	50	60	8,75	8,45	0,338	0,344	24	
L.050HF	Glazed-in louvres	484	50	60	8,75	8,45	0,338	0,344	42	
L.050W	Built-in wall louvres	L.050W	50	57	10,47	16,50	0,310	0,246		
L.060HF	Built-in wall louvres	480	60	76	5,59	5,62	0,423	0,422	23	
L.060HF	Glazed-in louvres	483	60	76	5,59	5,62	0,423	0,422	41	
L.066.01	Built-in wall louvres	451	66	49	12,71	11,77	0,280	0,291	20	
L.066V	Built-in wall louvres	  452	66	41	66,1	79,7	0,123	0,112	21	
L.066V	Built-in wall louvres	 452v	66	41	60,1	79,9	0,129	0,114	21	
L.065AL	Built-in wall louvres	453	65	55	13,32	17,08	0,274	0,242	22	

Remark: test results according to louvres including mesh



Family					Airflow				Page
Blade type Linius	Louvre type	Product type	Blade pitch	Physical free area	K-factor (supply)	K-factor (discharge)	Coeffi- cient C _e	Coeffi- cient C _d	
L.095.01	Built-in wall louvres	425	95	55	11,41	11,65	0,296	0,293	17
L.095.01	Glazed-in louvres	425/GL	95	55	11,41	11,65	0,296	0,293	44
mouvable blade	Built-in wall louvres	427	100	53	11,41	11,65	0,296	0,293	18
mouvable blade	Glazed-in louvres	427/GL	100	53	11,41	11,65	0,296	0,293	45
L.060AC	Acoustic louvres	445/86	60	34	9,22	13,29	0,329	0,274	46
L.150ACS.01	Acoustic louvres	446/150	150	34,3	38,46	34,48	0,161	0,169	48
L.150ACL.01	Acoustic louvres	446/225	150	34,3	37,3	41,9	0,164	0,15	48
L.150ACS.01	Acoustic louvres	446/300	150	34,3	45,93	45,93	0,148	0,148	48
L.150ACS.01	Acoustic louvres	447/150	170	37	25,46	25,15	0,198	0,200	50
L.150ACL.01	Acoustic louvres	447/225	170	37	28,58	30,88	0,187	0,180	50
acoustic	Acoustic louvres	468AK	85	29	86,85	89,35	0,107	0,106	52
floor grille	Floor grilles	311	16,5	76	n.a.	n.a.	n.a.	n.a.	64
floor grille	Floor grilles	371	20,5	61	n.a.	n.a.	n.a.	n.a.	65
punched	Ventilation grilles	381	n.a.	80	n.a.	n.a.	n.a.	n.a.	63
bar blade	Linear bar grilles	392	13	76	n.a.	n.a.	n.a.	n.a.	66
bar blade	Linear bar grilles	394	16,5	59	n.a.	n.a.	n.a.	n.a.	67
punched	Punched grilles	435R	n.a.	n.a.	n.a.	n.a.	n.a.	n.a.	61
slide blade	Controllable internal louvres	4032	n.a.	n.a.	n.a.	n.a.	n.a.	n.a.	59
slide blade	Controllable internal louvres	441	n.a.	n.a.	n.a.	n.a.	n.a.	n.a.	58
slide blade	Controllable internal louvres	442	n.a.	n.a.	n.a.	n.a.	n.a.	n.a.	57
door blade	Door grilles	461	20	39	33,8	33,8	0,172	0,172	68
extractor	Surface-mounted louvres	433	n.a.	n.a.	n.a.	n.a.	n.a.	n.a.	32
door blade	Door grilles	469 Invisido	n.a.	n.a.	17,03	17,03	0,24	0,24	70
door blade	Door grilles	461AK Silendo	n.a.	27	6,13	6,13	0,40	0,40	69
burglarproof blade	Burglarproof louvres	421WK2	50	43	13,82	12,85	0,269	0,279	53
burglarproof blade	Burglarproof louvres	423WK4	50	22	27,06	27,28	0,193	0,192	55
L.033.07	Burglarproof louvres	431WK2	33,3	40,5	23,56	25,51	0,206	0,198	54
fire blade	Fire blade	464 Incendo	20	51	10,27	10,27	0,312	0,312	72
fire blade	Fire blade	465	17,5	57	10,27	10,27	0,312	0,312	73
fire blade	Fire blade	466	20	70	6,82	6,82	0,383	0,383	74
galvanised blade	Built-in wall louvres	511	33,3	43	n.a.	n.a.	n.a.	n.a.	26
galvanised blade	Built-in wall louvres	521	33,3	47	n.a.	n.a.	n.a.	n.a.	27
stainless blade	Built-in wall louvres	621	50	47	n.a.	n.a.	n.a.	n.a.	28
controllable	Controllable internal louvres	XD	n.a.	n.a.	n.a.	n.a.	n.a.	n.a.	60

Watertightness tests < Introduction

Method for watertightness (HEVAC) testing

All RENSON® louvres have been subjected to European HEVAC testing (according to EN 13030) by the internationally accredited corporation BSRIA Ltd. During these tests, a louvre equipped with stainless steel insect mesh of 1 m² are subjected to simulated heavy rain by being sprayed with water at a rate of 75 litres per hour at a wind speed of 13.5 m/second. HEVAC classification is based on the results obtained, i.e. the quantity of water infiltrating through the louvre.

Attention: The reference “air speed” in this document always refers to the air speed at suction side. In case a louvre gets classified a certain watertightness, this suction side air speed always needs to be indicated. The outside wind speed is fixed to 13m/s and is never mentioned.

Remark:

In case of a weatherable louvre, RENSON® advises to apply a drainage profile and waterchannel sealing the seams of the frame will guarantee an even better weatherability.



Without waterchannel
Test on a standard type 411 louvre

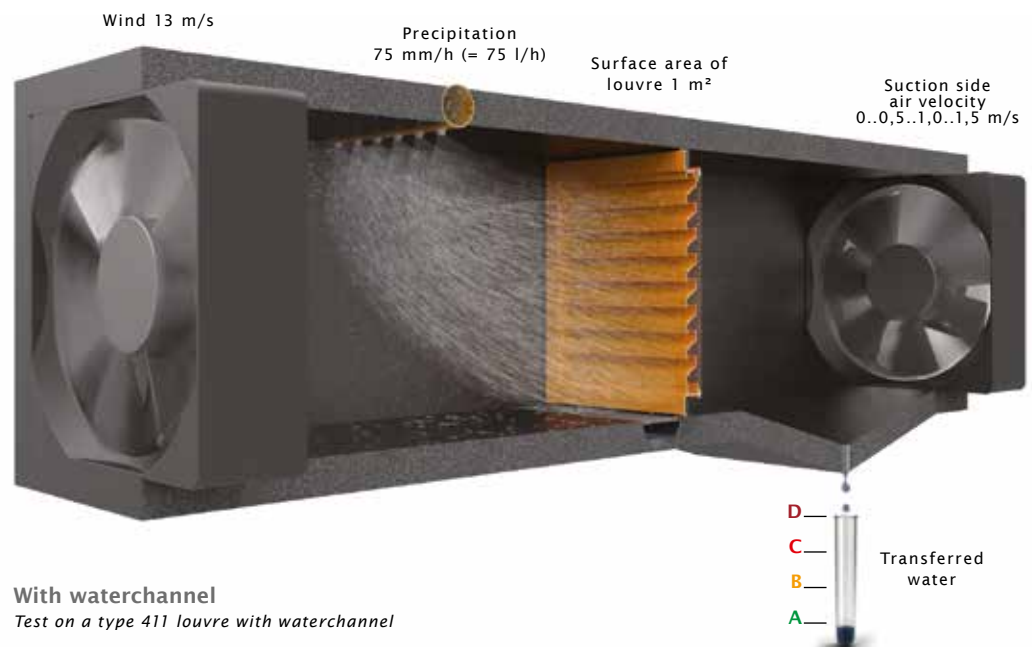

With waterchannel
Test on a type 411 louvre with waterchannel

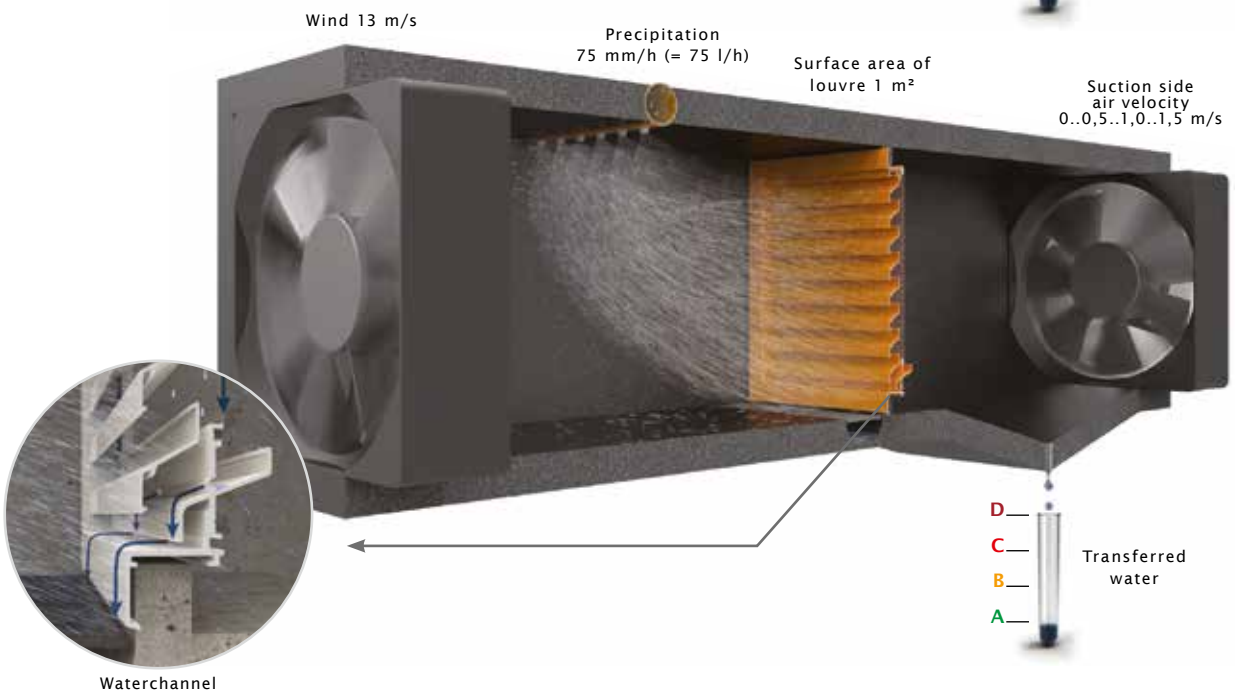

	Class	% water infiltration	Air resistance class
Very good rain protection	A	0 - 1%	$C_e > 0,4 : 1$
Good rain protection	B	1,1 - 5%	$0,3 < C_e < 0,4 : 2$
Average rain protection	C	5,1 - 20%	$C_e : 0,2 - 0,299 : 3$
Low rain protection	D	> 20%	$C_e < 0,199 : 4$

Type of louvre	Suction air speed (m/s)	Standard design		With water channel		Suction air resistance class (C_e -coefficient)
		%	Class	%	Class	
<i>With 2.3 x 2.3 mm insect screen</i>						
411/414 L.033.01	0,0	96,7	B	98,7	B	4
	0,5	95,0	B	98,0	B	4
	1,0	93,3	C	96,4	B	4
	1,5	< 80	D	88,5	C	4
	2,0					
412/415 V20-blade	0,0	98,1	B	99,5	A	4
	0,5	96,9	B	99,0	A	4
	1,0	89,96	C	98,0	B	4
421/424 L.050.00	0,0	90,6	C	96,9	B	3
	0,5	87,7	C	95,6	B	3
	1,0	< 80	D	93,7	C	3
	1,5	< 80	D	89,0	C	3
	2,0					
425 L.095.01	0,0	82,0	C	96,6	B	3
	0,5	74,8	D	93,9	C	3
	1,0	< 80	D	90,0	C	3
	1,5	< 80	D	83,5	C	3
	2,0	< 80	D	76,3	D	3
451 L.066.01	0,0	91,0	C	98,0	B	3
	0,5	89,3	C	96,1	B	3
	1,0	87,1	C	94,2	C	3
	1,5	81,6	C	89,5	C	3
	2,0	70,7	D			
452 L.066	0,0	-	-	100,0	A	4
	0,5	-	-	99,9	A	4
	1,0	-	-	99,6	A	4
	1,5	-	-	94,0	B	4
	2,0	-	-	56,9	D	4
2,5	-	-	28,3	D	4	
452V L.066V	0,0	-	-	100,0	A	4
	0,5	-	-	100,0	A	4
	1,0	-	-	100,0	A	4
	1,5	-	-	99,7	A	4
	2,0	-	-	80,2	C	4
	2,5	-	-	11,3	D	4
3,0	-	-	7,9	D	4	
491/494 L.033.08	0,0	-	-	100,0	A	4
	0,5	-	-	99,7	A	4
	1,0	-	-	91,6	B	4
	1,5	-	-	50,1	D	4
	2,0	-	-	16,3	D	4
2,5	-	-	14,7	D	4	
431 L.033.01	0,0	96,7	B	-	-	4
	0,5	95,0	B	-	-	4
	1,0	93,3	C	-	-	4
	1,5	< 80	D	-	-	4
	2,0			-	-	
<i>With 6 x 6 mm insect mesh</i>						
421/424 L.050.00	0,0	84,2	C	94,2	C	3
	0,5	81,0	C	91,8	C	3
	1,0	< 80	D	89,5	C	3
	1,5			85,7	C	3
	2,0					
422/428 L.033V	0,0	99,3	A	99,93	A	4
	0,5	98,11	B	99,46	A	4
	1,0	93,39	C	96,91	B	4
	1,5	87,46	C	87,92	C	4
	2,0	59,97	D	62,24	D	4
	2,5	25,03	D	21,99	D	4
3,0	17,94	D	18,08	D	4	
425 L.095.01	0,0	< 80	D	91,3	C	3
	0,5			88,3	C	3
	1,0			85,1	C	3
	1,5			79,4	D	3
	2,0					
451 L.066.01	0,0	85,4	C	92,0	B	3
	0,5	83,6	C	90,1	B	3
	1,0	< 80	D	88,2	C	3
	1,5			83,5	C	3
	2,0					
L.050W	0,0	100	A	-	-	2
	0,5	100	A	-	-	2
	1,0	100	A	-	-	2
	1,5	100	A	-	-	2
	2,0	99,9	A	-	-	2
	2,5	99,9	A	-	-	2
	3,0	99,2	A	-	-	2

How to select the correct louvre for your application?

The tools and data below provide you an overview of the available services to select the correct louvre and required information.

Website uk.renson.eu

On the website <http://uk.renson.eu> you can find an overview of all louvres including technical drawings, leaflets and product summaries (NBS specs).



- Selection and calculation software
- Selection and calculation of the right louvre making use of the louvre software available on the download page of the Renson website.
- <http://uk.renson.eu/downloads-united-kingdom.html>

When placing the order for a made-to-measure louvre, please provide at least two of the following parameters:

- Surface of the opening
- Pressure drop over the louvre in Pa
- Required airflow in m³/h



Specific louvre characteristics

- Burglarproof:** louvre tested according to official WK (Wiederstandsklasse) classification
- Acoustic damping:** louvre equipped with acoustic mineral wool to reduce noise
- Water-proof:** louvre with high HEVAC classification (ref page 9)
- Stick-proof:** this louvre has been IP certified (EN 60529)

Nightcooling

By passing large amounts of natural air through the building during nighttime and blocking the sun during the day, the building-mass gets cooled and the indoor temperature remain stable during the day. Nightcooling can be achieved by placing specific louvres at the suction and discharge side of

Test reports
Louvres with specific requirements have been tested according to EN norms. Test reports for IP-classification, burglar-proof, acoustic damping and weatherability are available on demand.



Drainage profil

This profile is designed for all types of aluminium rectangular wall louvres

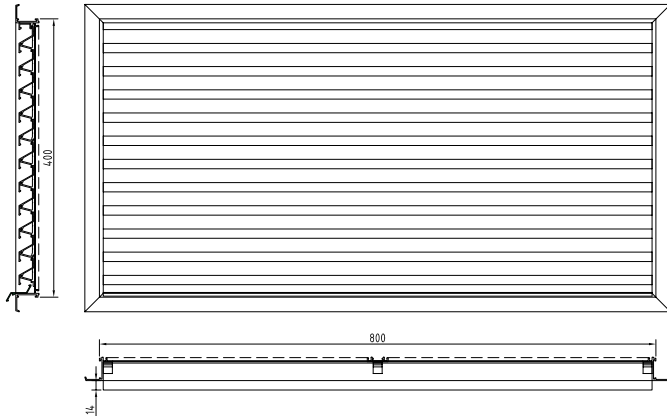

Louvre with strengthening support

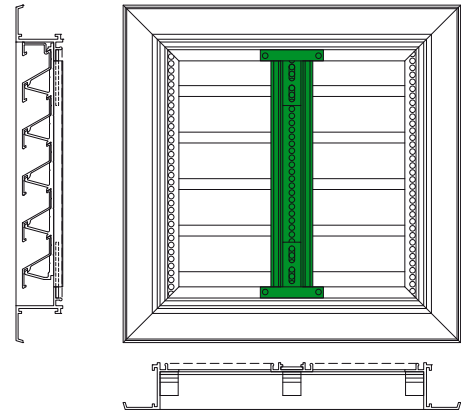

Remark: a strengthening support is standard for a louvre wider than 700mm.

Coupled louvres

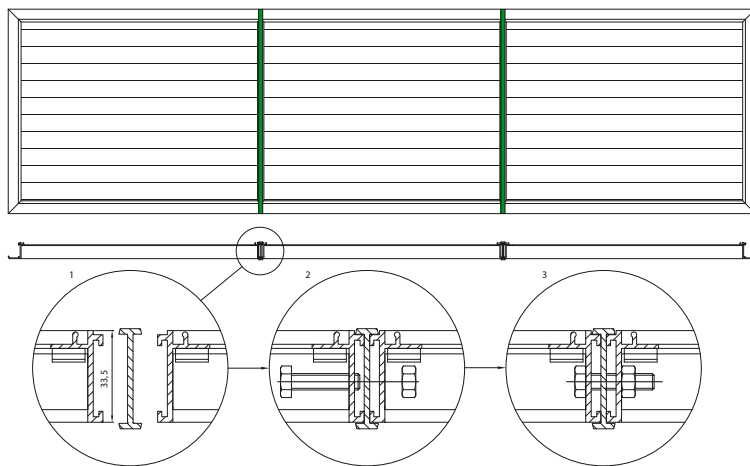

- Louvres can be coupled both vertically and horizontally
- Standard vertical

Dust filter

- This profile is designed for all louvre types
- Equipped with dust filter class G4

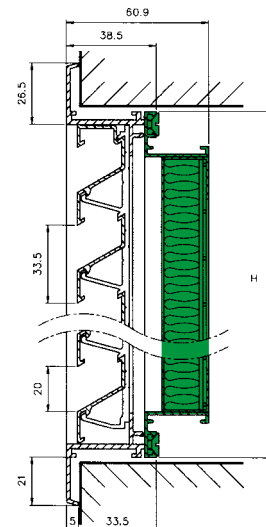

Removable mosquito mesh

Material

- Pick-up angle (non-visible) in polyamide
- Mesh in stainless steel 304
 - 6x6 mm
 - 2.3x2.3 mm
 - 10x10 mm

Dimensions

- Minimum dimensions: 190x190 mm
- Maximum dimensions : 1500x1200 mm

Advantages

- Integrated water channel
- Aesthetical mesh
- No technical details visible

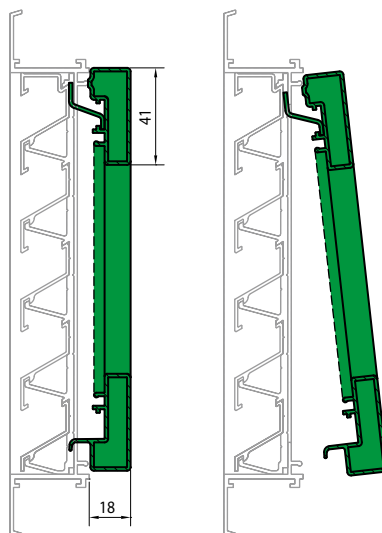

Water channel

- It collects any water infiltration and channels it outside.
- This profile is designed for many louvre types

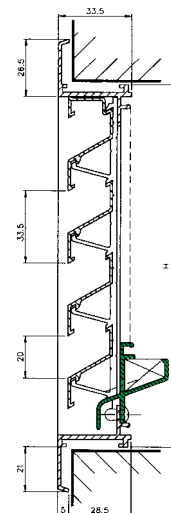

411 < Built-in wall louvres



411 with thermal insulation panel

Wall louvre, standard series, pitch 33

Material

- Made from aluminium sections: AlMgSi 0.5 (according to EN 12020-2)
- Stainless steel 304 insect screen (2.3 x 2.3 mm) or mesh (6 x 6 mm) on request
- Finishing: anodized in satin/bronze colour (20 micron) or powder-coated in any RAL or Syntha Pulvin colour (40 micron)

Dimensions

- Blade pitch: 33,3 mm
- Depth to fit: 29 mm
- Flange size: 21 mm
- Minimum dimensions: 100 x 100 mm

Fixing

- Brackets ref. 418
- Spring clips ref. 419 available on request (small dimensions)
- For louvres larger than approx. 3 m², a reinforcing mullion is required to suit span and windload

Options (page 11)

- Water channel
- Drainage profile
- Removable insect mesh
- Backframe
- Filter
- Special shape (see next page)
- Controllable (see next page)
- Without flange (see next page)

Typical applications

- Every application without specific needs

Stock models

Dimensions	Satin anodised	RAL 9010
200 x 200	•	•
300 x 200	•	•
300 x 300	•	•
400 x 200	•	•
400 x 300	•	•
400 x 400	•	•
500 x 300	•	•
500 x 400	•	•
500 x 500	•	•
600 x 300	•	•
600 x 400	•	•
600 x 600	•	•
700 x 700	•	•
1000 x 500	•	
1000 x 1000	•	
300 x 112	•	
350 x 142	•	
400 x 162	•	
111 x 112	•	
142 x 142	•	•
162 x 162	•	•

Cross-sections

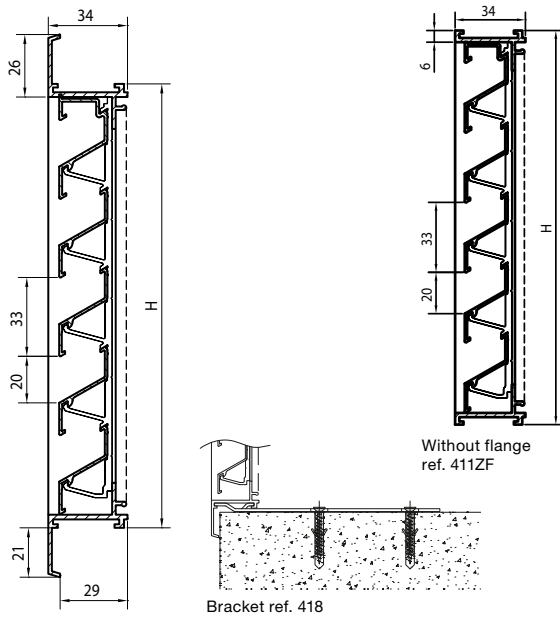

Options

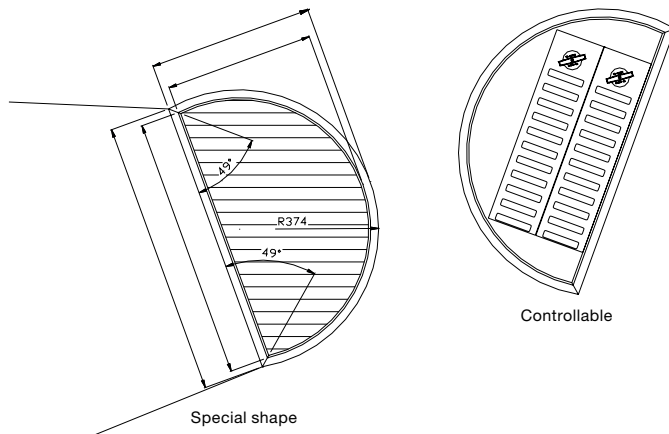

Technical specifications

	411
Airflow	(EN 13030)
K-factor (supply)	23,56
K-factor (discharge)	25,51
C _e coefficient	0,206
C _d coefficient	0,198
Technical data	
Visual free area	59 %
Physical free area	45 %
IP class (louvre with mesh; electrical installation at least 100mm from louvre)	IP2XD

412 < Built-in wall louvres

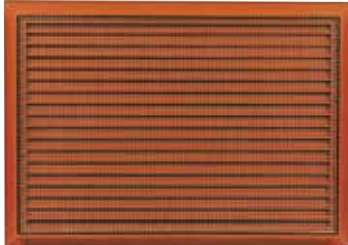
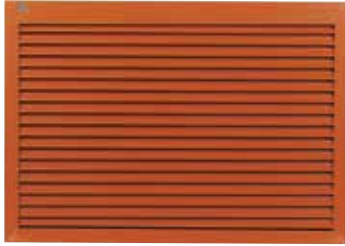

412 with dust filter

Wall louvre with chevron section blades, pitch 20

Material

- Made from aluminium sections: AlMgSi 0.5 (according to EN 12020-2)
- Stainless steel 304 mesh (6 x 6 mm) or insect screen (2.3 x 2.3 mm) on request
- Finishing: anodized in satin/bronze colour (20 micron) or powder-coated in any RAL or Syntha Pulvin colour (40 micron)
- Equipped with earthing lug

Dimensions

- Blade pitch: 20 mm chevron
- Depth to fit: 29 mm
- Flange size: 21 mm
- Minimum dimensions: 100 x 100 mm

Fixing

- Brackets ref. 418
- Spring clips ref. 419 available on request (small dimensions)
- For louvres larger than approx. 3 m², a reinforcing mullion is required to suit span and windload

Options

- Water channel
- Drainage profile
- Removable insect mesh
- Backframe
- Filter
- Without flange

Typical applications

- High-voltage stations
- IT rooms

Stock models	
Dimensions	Satin anodised
200 x 200	•
300 x 300	•
400 x 300	•
500 x 300	•
600 x 400	•

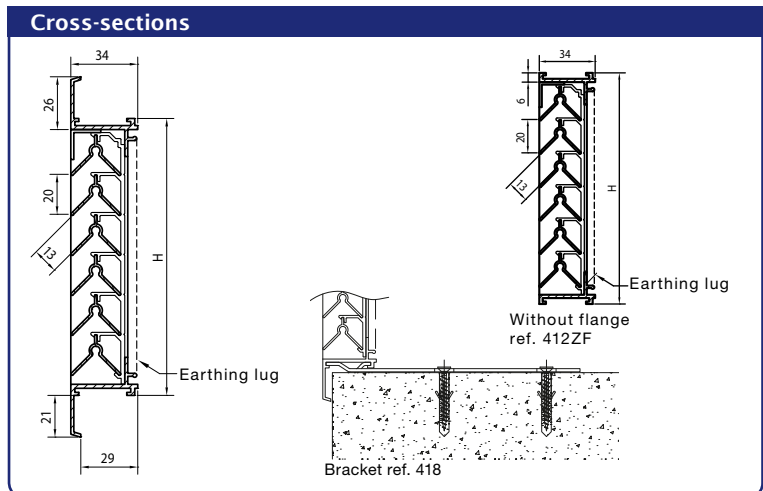

Technical specifications	
	412
Airflow (EN 13030)	
K-factor (supply)	33,80
K-factor (discharge)	33,80
C _e coefficient	0,172
C _d coefficient	0,172
Technical data	
Visual free area	93 %
Physical free area	39 %
IP class	IP2XD

Wall louvre, heavy-duty series, pitch 50

Material

- Made from aluminium sections: AlMgSi 0.5 (according to EN 12020-2)
- Stainless steel 304 insect screen (2.3 x 2.3 mm) or mesh (6 x 6 mm) on request
- Finishing: anodized in satin/bronze colour (20 micron) or powder-coated in any RAL or Syntha Pulvin colour (40 micron)

Dimensions

- Blade pitch: 50 mm
- Depth to fit: 46 mm
- Flange size: 40 mm
- Minimum dimensions: 150 x 150 mm

Fixing

- Brackets ref. 1428
- For louvres larger than approx. 3 m², a reinforcing mullion is required to suit span and windload

Options

- Water channel
- Drainage profile
- Removable insect mesh
- Filter
- Burglarproof louvre 421WK2 (ref page 53)
- Without flange

Typical applications

- Applications where aesthetics and strength are key parameters.

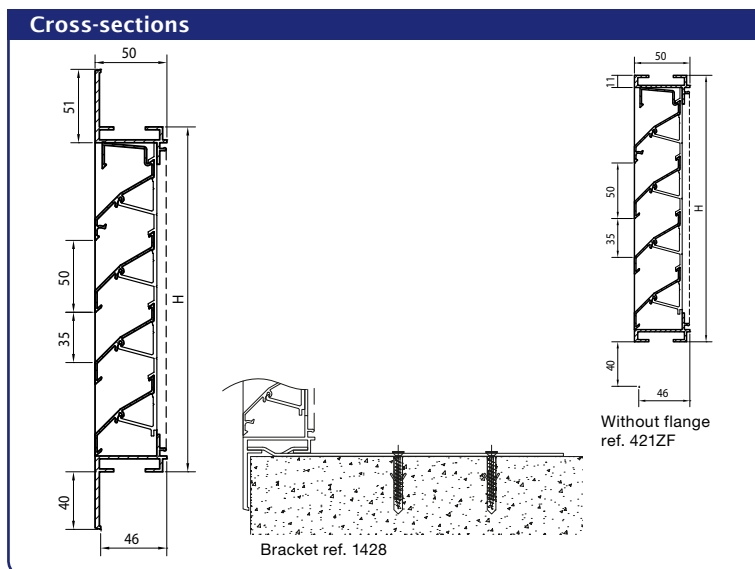

Technical specifications	
	421
Airflow	(EN 13030)
K-factor (supply)	12,57
K-factor (discharge)	8,91
C _e coefficient	0,282
C _a coefficient	0,335
Technical data	
Visual free area	70 %
Physical free area	49 %
IP class (louvre with mesh; electrical installation at least 100mm from louvre)	IP2XD



422 < Built-in wall louvres



Wall louver with chevron section blades, heavy-duty series, pitch 33

Material

- Made from aluminium sections: AlMgSi 0.5 (according to EN 12020-2)
- Stainless steel 304 mesh (2.3x 2.3 mm) or insect screen (6 x 6 mm) on request
- Finishing: anodized in satin/bronze colour (20 micron) or powder-coated in any RAL or Syntha Pulvin colour (40 micron)

Dimensions

- Blade pitch: 33 mm
- Depth to fit: 46 mm
- Flange size: 40 mm
- Minimum dimensions: 150 x 150 mm

Fixing

- Brackets ref. 1428
- For louvres larger than approx. 3 m², a reinforcing mullion is required to suit span and windload

Options

- Water channel
- Drainage profile
- Removable insect mesh
- Filter
- Without flange

Typical applications

- Applications where extreme strength and stick-proof are key parameters.

Cross-sections

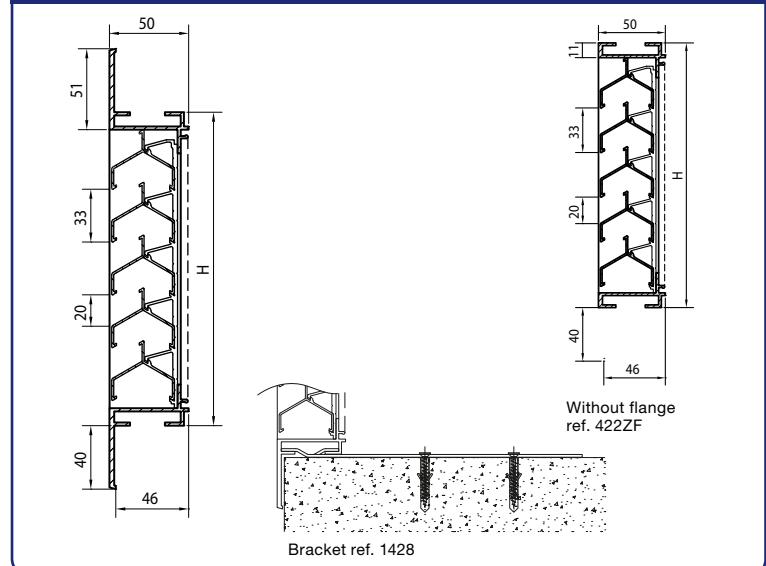

Technical specifications

422	
Airflow	(EN 13030)
K-factor (supply)	61,04
K-factor (discharge)	61,04
C _e coefficient	0,128
C _d coefficient	0,128
Technical data	
Visual free area	59 %
Physical free area	43 %

Wall louvre, extra-heavy-duty series, pitch 95

Material

- Made from aluminium sections: AlMgSi 0.5 (according to EN 12020-2)
- Stainless steel 304 mesh (6 x 6 mm) or mesh (2.3 x 2.3 mm) on demand
- Finishing: anodized in satin/bronze colour (20 micron) or powder-coated in any RAL or Syntha Pulvin colour (40 micron)

Dimensions

- Blade pitch: 95 mm
- Depth to fit: 81,5 mm
- Flange size: 50 mm
- Minimum dimensions: 300 x 300 mm

Fixing

- Brackets ref. 429
- For louvres larger than approx. 3 m², a reinforcing mullion is required to suit span and windload

Options

- Water channel
- Drainage profile
- Removable insect mesh
- Filter
- Without flange

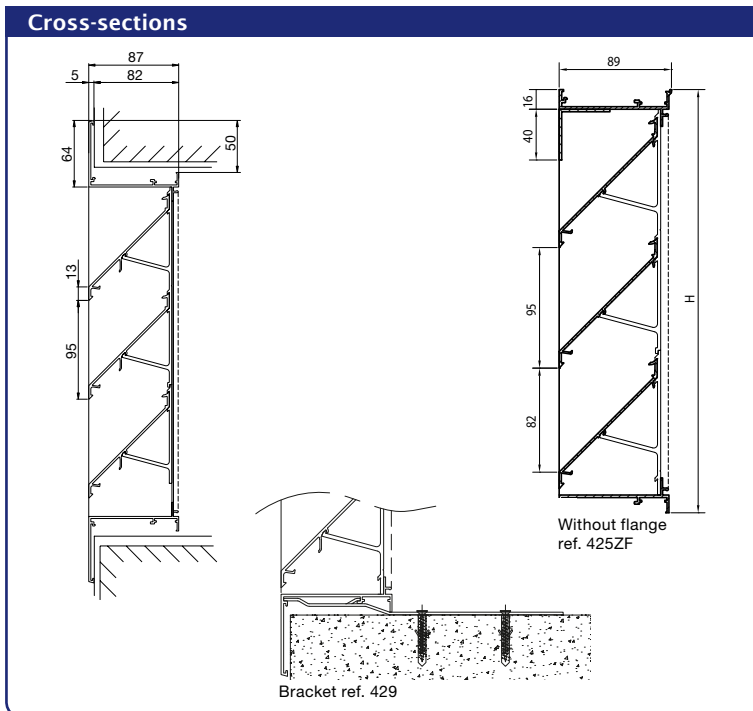

Technical specifications	
	425
Airflow	(EN 13030)
K-factor (supply)	11,41
K-factor (discharge)	11,65
C _e coefficient	0,296
C _d coefficient	0,293
Technical data	
Visual free area	86 %
Physical free area	55 %

427 < Built-in wall louvres



Type 427/1

427/1 - 427/2 - 427/3 - 427/4 - 427/5
Wall louver, extra-heavy-duty series,
with adjustable blades

Material

- Made from aluminium sections: AlMgSi 0.5 (according to EN 12020-2)
- Stainless steel 304 mesh (6 x 6 mm) or mesh 304 (2.3 x 2.3 mm) on demand
- Finishing: anodized in satin/bronze colour (20 micron) or powder-coated in any RAL or Syntha Pulvin colour (40 micron)

Dimensions

- Height = (multiple of 100) + 90 mm
- Maximum width in one piece: 1300 mm
- Minimum dimensions: 300 x 290 mm
- Depth to fit: 81.5 mm
- Flange size: 50 mm

Fixing

- Brackets ref. 429

Options

- Without flange

Control options

- Manual 427/1
- Cable 427/2
- Ultraflex 427/3
- Motor 427/4
- Air pressure 427/5

Typical applications

- Powers stations
- High buildings
- Controlled ventilation
- Production halls



Type 427/2



Type 427/3



Type 427/4



Type 427/5

Technical specifications

427	
(EN 13030)	
Airflow (in open position)	11,41
K-factor (supply)	11,65
K-factor (discharge)	0,296
C _e coefficient	0,293
C _d coefficient	
Technical data	
Visual free area	88 %
Physical free area	53 %

Cross-sections

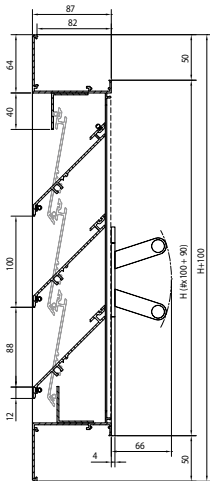

Type 427/1
Manual control
Minimum louvre
height: 290 mm

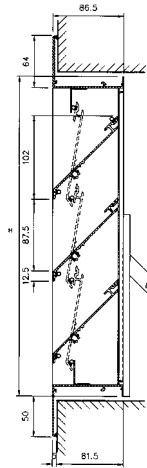

Type 427/2
Cable control up to 5000 mm
Minimum louvre
height: 390 mm

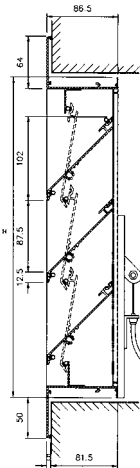

Type 427/3
Ultraflex control up
to max. 7 m
Minimum louvre
height: 690 mm

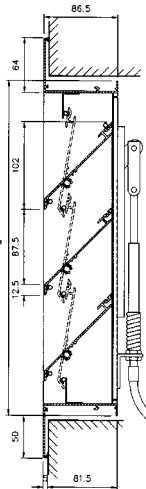

Type 427/4
220 V/24 V motor
control
Minimum louvre
height: 390 mm

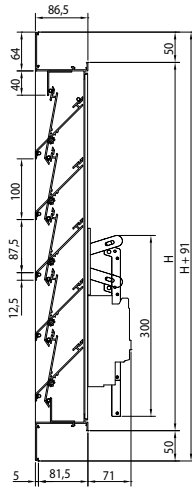

Type 427/5
Air pressure control
Minimum louvre
height: 390 mm

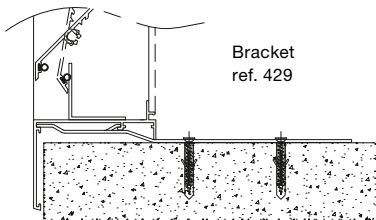

Bracket
ref. 429

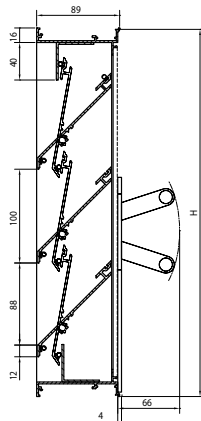

Without flange
ref. 427ZF



451 < Built-in wall louvres



Wall louvre, heavy-duty series, pitch 66

Material

- Made from aluminium sections: AlMgSi 0.5 (according to EN 12020-2)
- Stainless steel 304 mesh (6 x 6 mm) or insect screen (2.3 x 2.3 mm) on request
- Finishing: anodized in satin/bronze colour (20 micron) or powder-coated in any RAL or Syntha Pulvin colour (40 micron)

Dimensions

- Blade pitch: 66 mm
- Depth to fit: 60 mm
- Flange size: 25 mm
- Minimum dimensions: 300 x 300 mm

Fixing

- Brackets ref. 429
- For louvres larger than approx. 3 m², a reinforcing mullion is required to suit span and windload

Options

- Water channel
- Drainage profile
- Removable insect mesh
- Filter
- Variable blade pitch possible between 66 and 132 mm
- Without flange

Typical applications

- Industrial, commercial with large blade pitch



Cross-sections

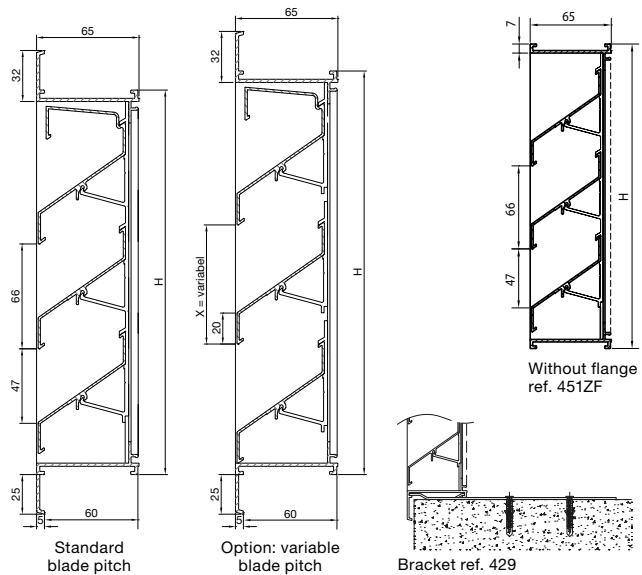

Technical specifications

451	
Airflow (EN 13030)	
K-factor (supply)	13,62
K-factor (discharge)	14,91
C _e coefficient	0,271
C _d coefficient	0,259
Technical data	
Visual free area	70 %
Physical free area	49 %

Wall louvre, heavy-duty series with chevron section blades, pitch 66

Material

- Made from aluminium sections: AlMgSi 0.5 (according to EN 12020-2)
- Stainless steel 304 mesh (6 x 6 mm) or insect screen (2.3 x 2.3 mm) on request
- Finishing: anodized in satin/bronze colour (20 micron) or powder-coated in any RAL or Syntha Pulvin colour (40 micron)

Dimensions

- Blade pitch: 66 mm
- Depth to fit: 82 mm
- Flange size: 50 mm
- Minimum dimensions: 300 x 300 mm

Fixing

- Brackets ref. 429
- For louvres taller than approx. 3 m², a reinforcing mullion is required to suit span and windload

Options

- Water channel, drainage profile, removable insect mesh, filter, without flange

Typical applications

- Application where high strength, stick-proof and excellent weatherability are important selection criteria.
- High-voltage cabins
- HVAC
- No see-through

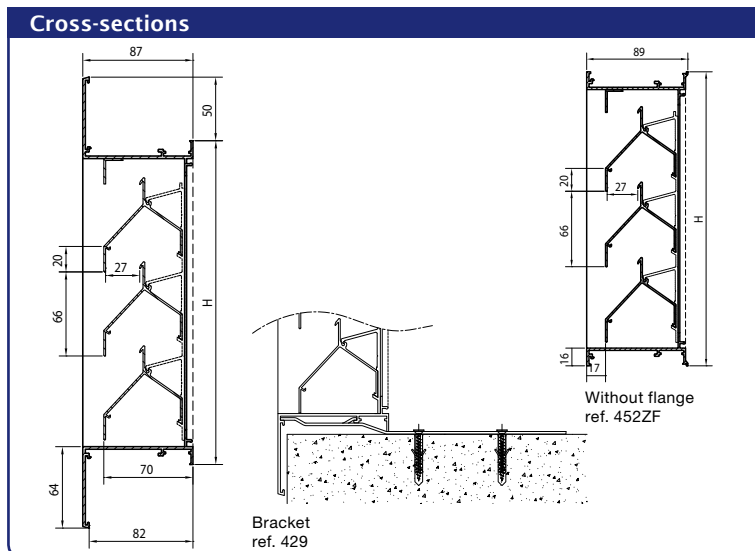

452V



Technical specifications		
	452	452V
Airflow	(EN 13030)	(EN 13030)
K-factor (supply)	66,1	60,1
K-factor (discharge)	79,7	79,9
C _e coefficient	0,123	0,129
C _d coefficient	0,112	0,114
Technical data		
Visual free area	70 %	70 %
Physical free area	41 %	41 %
IP class (louvre with mesh)	IP2XD	IP2XD
HEVAC class	A (1m/s)	A (1,5m/s)

453 < Built-in wall louvres



*Wall louvre, heavy-duty series,
with aluminium coil blades, pitch 65*

Material

- Frame made from aluminium sections: AlMgSi 0.5 (according to EN 12020-2)
- Roll-formed aluminium coil blades
- Stainless steel 304 mesh (6 x 6 mm) or insect screen (2.3 x 2.3 mm) on request
- Finishing: anodized in satin/bronze colour (20 micron) or powder-coated in any RAL or Syntha Pulvin colour (40 micron)

Dimensions

- Depth to fit: 60 mm
- Flange size: 25 mm
- Minimum dimensions: 300 x 300 mm

Fixing

- Brackets ref. 429
- For louvres larger than approx. 3 m², a reinforcing mullion is required to suit span and windload

Options

- Water channel
- Drainage profile
- Filter
- Without flange

Typical applications

- Very delicate basic louvre
- Aesthetical

Cross-sections

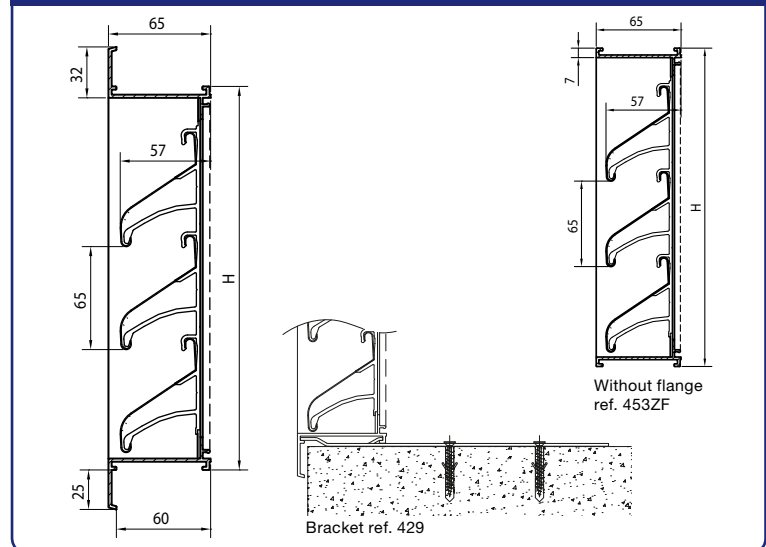

Technical specifications

	453
Airflow	(EN 13030)
K-factor (supply)	13,32
K-factor (discharge)	17,08
C _e coefficient	0,274
C _d coefficient	0,242
Technical data	
Visual free area	69 %
Physical free area	55 %

High-airflow wall louvres, pitch 60

Material

- Made from aluminium sections: AlMgSi 0.5 (according to EN 12020-2)
- Stainless steel 304 mesh (6 x 6 mm) or insect screen (2.3 x 2.3 mm) on request
- Finishing: anodized in satin/bronze colour (20 micron) or powder-coated in any RAL or Syntha Pulvin colour (40 micron)

Dimensions

- Depth to fit: 82 mm
- Flange size: 50 mm
- Minimum dimensions: 300 x 300 mm

Fixing

- Brackets ref. 429
- For louvres larger than approx. 3 m², a reinforcing mullion is required to suit span and windload

Options

- Water channel
- Drainage profile
- Removable mesh
- Filter
- Without flange

Typical applications

- Underground parkings
- Industrial applications

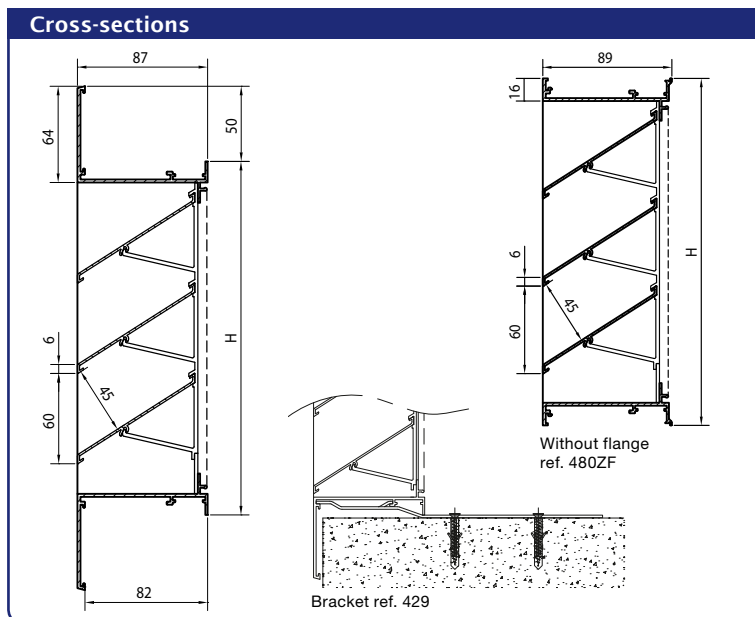

AIRFLOW

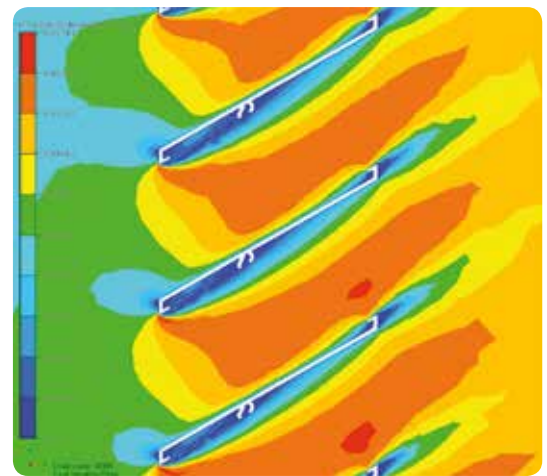

Supply

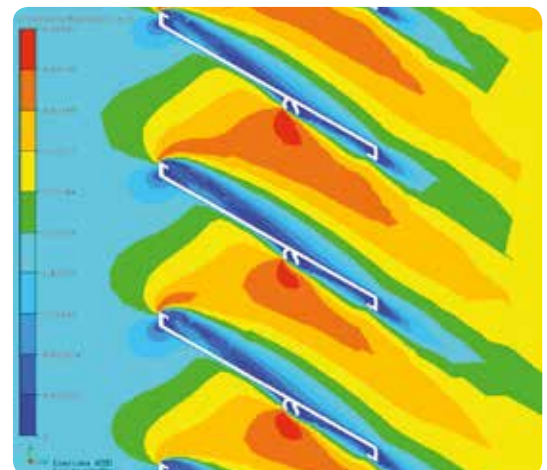

Discharge

Technical specifications	
	480
Airflow	(EN 13030)
K-factor (supply)	5,59
K-factor (discharge)	5,62
C _e coefficient	0,423
C _d coefficient	0,422
Technical data	
Visual free area	90 %
Physical free area	76 %
IP class (louvre with mesh; electrical installation at least 180mm from louvre)	IP2XD

481 < Built-in wall louvres



Wall louvre, heavy-duty series, pitch 50

Material

- Made from aluminium sections: AlMgSi 0.5 (according to EN 12020-2)
- Stainless steel 304 mesh (2.3 x 2.3 mm) or insect screen (6 x 6 mm) on request
- Finishing: anodized in satin/bronze colour (20 micron) or powder-coated in any RAL or Syntha Pulvin colour (40 micron)

Dimensions

- Blade pitch: 50 mm
- Depth to fit: 46 mm
- Flange size: 40 mm
- Minimum dimensions: 150 x 150 mm

Fixing

- Brackets ref. 1428
- For louvres larger than approx. 3 m², a reinforcing mullion is required to suit span and windload

Options

- Water channel
- Drainage profile
- Removable mesh
- Filter
- Variable pitch blade possible between 50 and 100 mm
- Without flange

Cross-sections

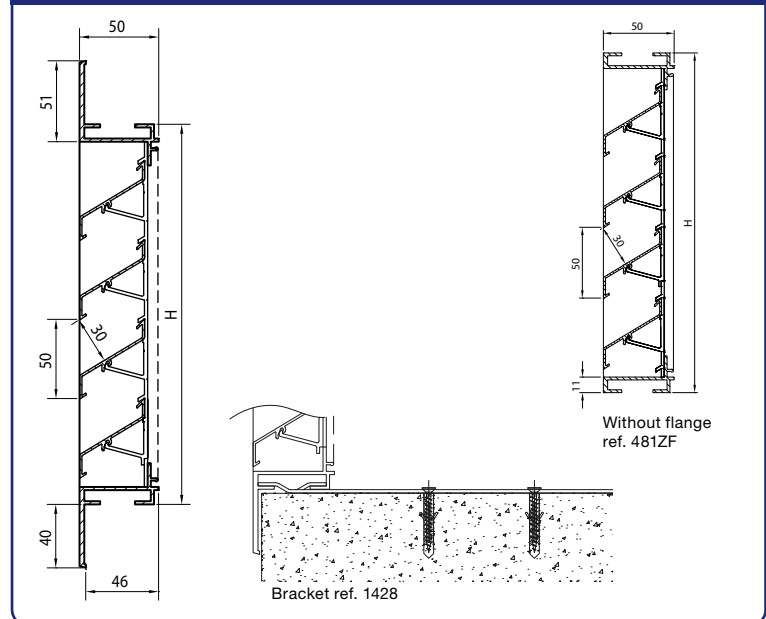

Technical specifications

	481
Airflow	(EN 13030)
K-factor (supply)	8,75
K-factor (discharge)	8,45
C _e coefficient	0,338
C _d coefficient	0,344
Technical data	
Visual free area	70 %
Physical free area	60 %
IP class (louvre with mesh; electrical installation at least 105mm from louvre)	IP2XD

“Storm” wall louvre, pitch 33

Material

- Made from aluminium sections: AlMgSi 0.5 (according to EN 12020-2)
- Stainless steel 304 mesh (6 x 6 mm) or insect screen (2.3 x 2.3 mm) on request
- Finishing: anodized in satin/bronze colour (20 micron) or powder-coated in any RAL or Syntha Pulvin colour (40 micron)

Dimensions

- Blade pitch: 33 mm
- Depth to fit: 29 mm
- Flange size: 21 mm
- Minimum dimensions: 100 x 100 mm

Fixing

- Brackets ref. 418

Options

- Water channel
- Removable mesh
- Filter
- Without flange
- Welded blades on frame

Typical applications

- Good weatherability combined with low airflow, applications with a lot of wind, coastal area
- Snow resistant

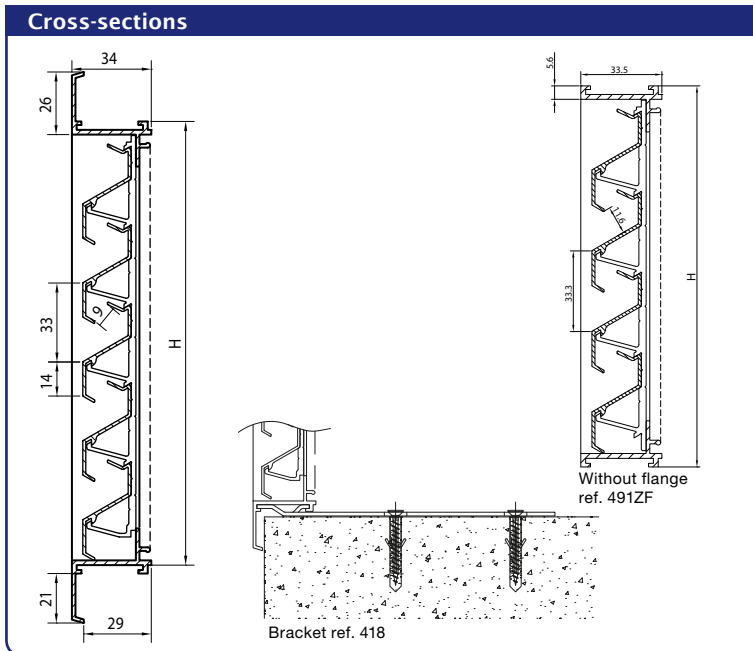

AIRFLOW

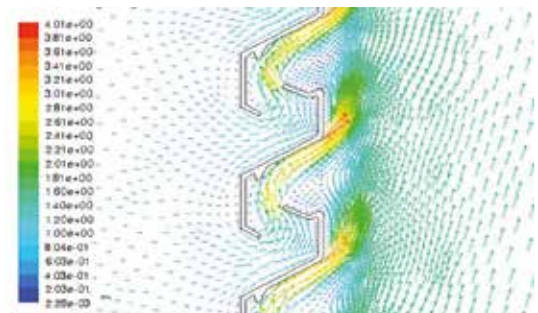

Supply

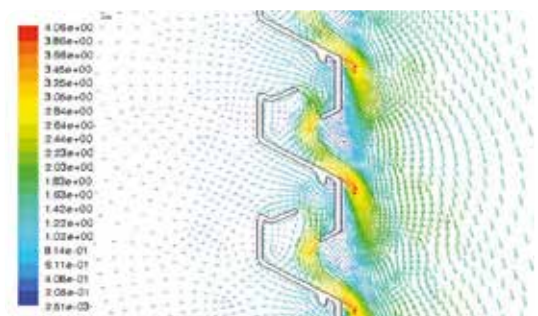

Discharge

Technical specifications	
	491
Airflow	(EN 13030)
K-factor (supply)	123,5
K-factor (discharge)	118,1
C _e coefficient	0,090
C _d coefficient	0,092
Technical data	
Visual free area	57 %
Physical free area	26 %



511 < Built-in wall louvres



Wall louvre, galvanised steel, pitch 34

Material

- Made from steel plate
- Electroplating: 10 micron FeZn12C
- Steel mesh (5 x 5 mm)
- Finishing: no powder-coating possible

Dimensions

- Blade pitch: 34 mm
- Depth to fit: 28 mm
- Flange size: 25 mm
- No made to measure

Typical applications

- Basic louvre
- Economical solution
- No power-coating possible
- Stronger than aluminium
- Anti-vandalism
- Sports centre

Stock models

Dimensions	Galvanised steel
200 x 200	•
300 x 300	•
400 x 200	•
400 x 300	•
400 x 400	•

Remark: only available in above mentioned sizes.

Cross-section

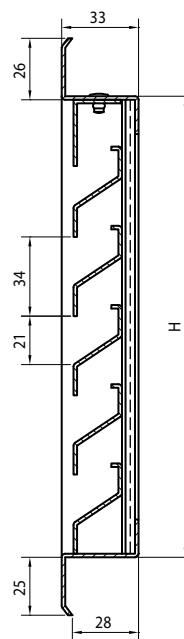

Technical specifications

511	
Technical data	
Visual free area	61 %
Physical free area	43 %

Wall louvre, heavy-duty series, galvanised steel, pitch 50

Material

- Made from steel plate
- Electroplating: 10 micron FeZn12C
- Finishing: powder coating in any RAL or Syntha PulvinR colour (min 40 microns)
- Steel mesh (13 x 13 mm)

Dimensions

- Blade pitch: 50 mm
- Depth to fit: 43 mm
- Flange size: 40 mm
- Minimum dimensions: 200 x 200 mm
- maximum dimensions: 2000 x 2000 mm

Fixing

- Brackets pre-fitted to the frame

Typical applications

- Basic louvre
- Economical solution
- Containers

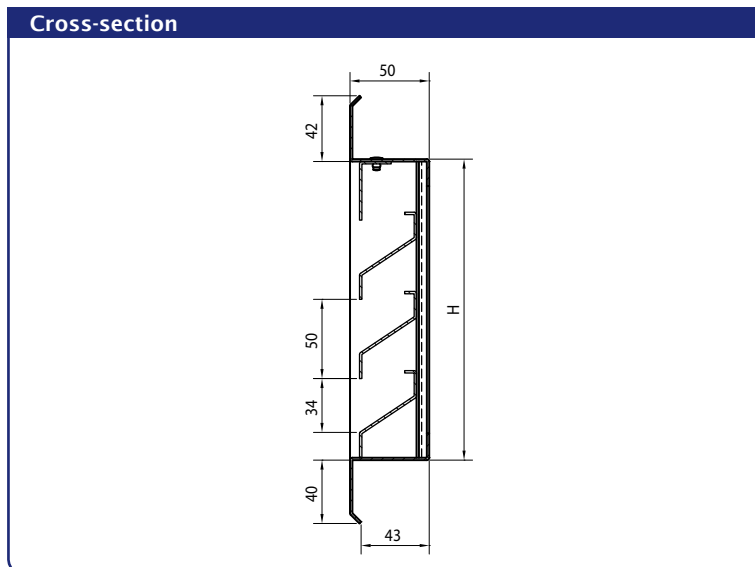

Stock models

Dimensions	Galvanised steel
300 x 300	•
400 x 400	•
500 x 500	•
600 x 400	•
600 x 600	•
1000 x 500	•
1000 x 1000	•

Remark: available in standard sizes and made-to-measure.

Technical specifications	
	521
Technical data	
Visual free area	68 %
Physical free area	47 %

621 < Built-in wall louvres



Wall louvre, stainless steel, pitch 50

Material

- Made from stainless steel 316 L
- Stainless steel 304 mesh (6 x 6 mm)

Dimensions

- Blade pitch: 50 mm
- Depth to fit: 43 mm
- Flange size: 40 mm
- Minimum dimensions: 200 x 200 mm

Fixing

- Brackets pre-fitted to the frame

Typical applications

- Food sector
- Chemical sector
- Hospitals
- Environment with high corrosion

Cross-section

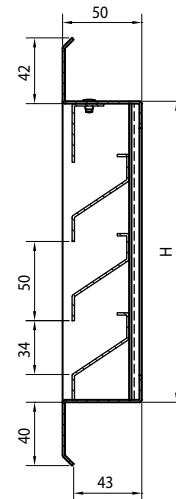

Technical specifications

621	
Technical data	
Visual free area	68 %
Physical free area	47 %

Surface-mounted wall louvre, pitch 33

Material

- Made from aluminium sections: AlMgSi 0.5 (according to EN 12020-2)
- Stainless steel 304 insect screen (2.3 x 2.3 mm) or mesh (6 x 6 mm) on request
- Finishing: anodized in satin/bronze colour (20 micron) or powder-coated in any RAL or Syntha Pulvin colour (40 micron)

Dimensions

- Blade pitch: 33,3 mm
- Thickness: 29 mm
- Minimum dimensions: 120 x 120 mm

Fixing

- Screws and plugs are included
- Louvre 432 is the removable version of louvre 431 (*pag. 31*)

Options

- Burglarproof louvre 431WK2 (*ref page 54*)

Typical applications

- Fixed louvre
- Nightcooling
- Standard surface-mounted louvre



Nightcooling

Stock models

Dimensions	Satin anodised	RAL 9010
165 x 165 mm	•	•
225 x 225 mm	•	•
325 x 325 mm	•	•
425 x 425 mm	•	
525 x 525 mm	•	

431 < Surface-mounted louvres

Cross-section

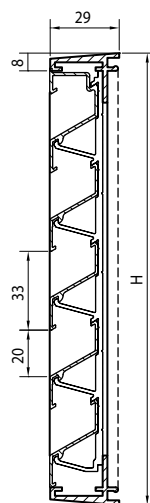

Technical specifications

	431
Airflow	(EN 13030)
K-factor (supply)	23,56
K-factor (discharge)	25,51
C _e coefficient	0,206
C _d coefficient	0,198
Technical data	
Visual free area	59 %
Physical free area	45 %
IP class (louvre with mesh; electrical installation at least 100mm from louvre)	IP2XD

Surface-mounted, glazed-in louvre with frame

Material

- Made from aluminium sections: AlMgSi 0.5 (according to EN 12020-2)
- Stainless steel 304 insect screen (2.3 x 2.3 mm) or mesh (6 x 6 mm) on request
- Finishing: anodized in satin/bronze colour (20 micron) or powder-coated in any RAL or Syntha Pulvin colour (40 micron)

Dimensions

- Blade pitch: 33 mm
- Thickness: 40 mm
- Minimum dimensions: 136 x 136 mm
- Maximum dimensions: 1500 x 1500 mm

Fixing

- Screws and plugs are included: 4 screws 35 x 35 mm & 4 plugs 6x30mm.

Typical applications

- Removable louvre

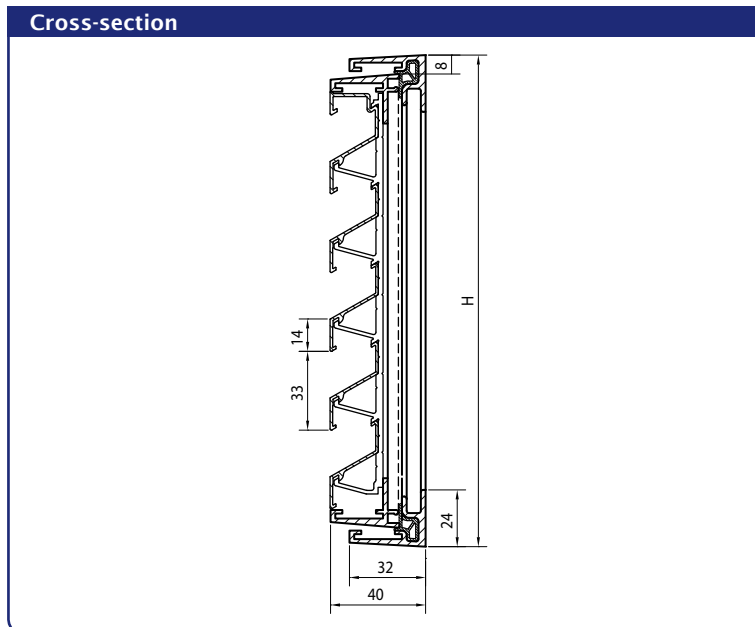

Technical specifications	
	432
Airflow	(EN 13030)
K-factor (supply)	23,56
K-factor (discharge)	25,51
C _e coefficient	0,206
C _d coefficient	0,198
Technical data	
Visual free area	59 %
Physical free area	45 %



433 < Surface-mounted louvres



Pressure-relief damper

Material

- Made from aluminium sections: AlMgSi 0.5 (according to EN 12020-2)
- Finishing: anodized in satin/bronze colour (20 micron) or powder-coated in any RAL or Syntha Pulvin colour (40 micron)
- Extractor hood louvres: the blades open at the same time
- Pressure-relief louvres: the blades open individually
- Without insect screen
- Opening pressure: 10 Pa standard, 20 Pa with enhanced blade

Dimensions

- The size is fixed with a minimum height of 228 mm + multiple of 100 mm
- In length, the blades are in one piece up to 800 mm

Fixing

- Invisible fixing
- Screws and plugs are included

Typical applications

- Extractor hood
- Drying cabinet

Stock models

Length x Height (L) x (H)	Satin anodised	RAL 9010	RAL 8019
Extractor hood louvres			
173 x 173 mm	•	•	•
210 x 210 mm	•	•	•
246 x 246 mm	•	•	•
Pressure-relief louvres			
328 x 328 mm	•	•	•
428 x 428 mm	•	•	•
528 x 528 mm	•	•	•

Cross-sections 433/S

Renson® Technology
extractor hood louver

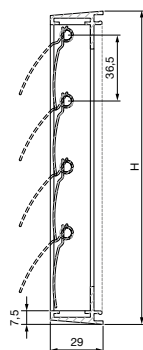

Other brand
extractor hood louver

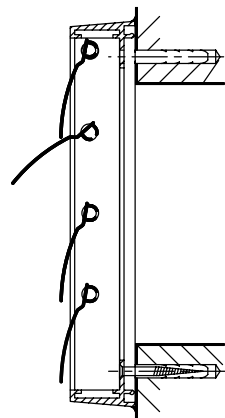

Cross-section 433/L

Pressure-relief louver

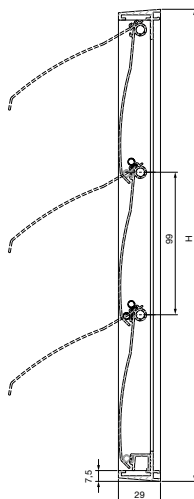

Glazed-in louvre, pitch 33

Material

- Made from aluminium sections: AlMgSi 0.5 (according to EN 12020-2)
- Stainless steel 304 insect screen (2.3 x 2.3 mm) or mesh (6 x 6 mm) on request
- Finishing: anodized in satin/bronze colour (20 micron) or powder-coated in any RAL or Syntha Pulvin colour (40 micron)

Dimensions

- Blade pitch: 33,3 mm
- Frame thickness: 24, 28 or 32 mm
- Minimum dimensions: 130 x 130 mm
- Specify on ordering: width x height in mm (overall dimensions)

Fixing

- Suitable for 24, 28, 32 mm glazing sections. Other thicknesses on request.

Options

- Water channel
- Removable mesh
- Filter
- Pressure-relief louvre

Typical applications

- Nightcooling

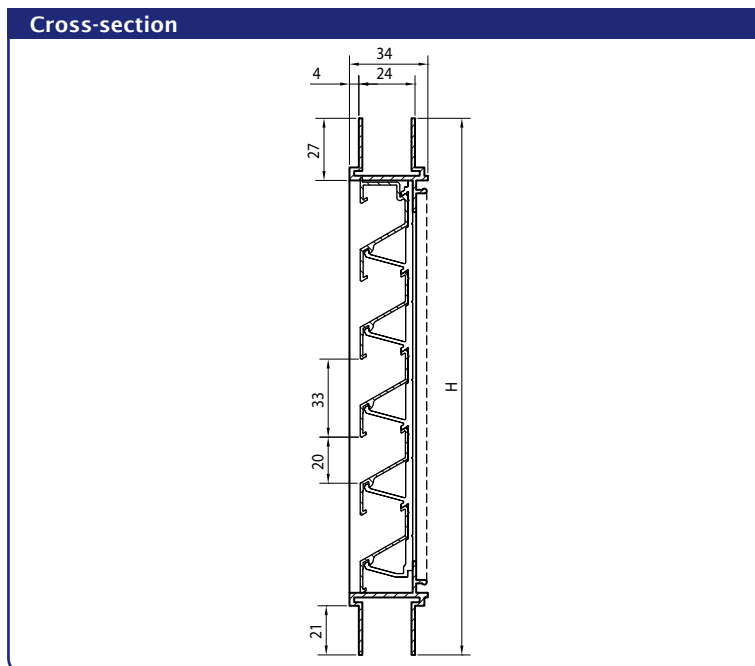

Technical specifications	
	414
Airflow	(EN 13030)
K-factor (supply)	23,56
K-factor (discharge)	25,51
C _e coefficient	0,206
C _d coefficient	0,198
Technical data	
Visual free area	59 %
Physical free area	45 %
IP class (louvre with mesh; electrical installation at least 100mm from louvre)	IP2XD



Pressure-relief grille

Combination of a pressure-relief louvre type 433 and a louvre type 414

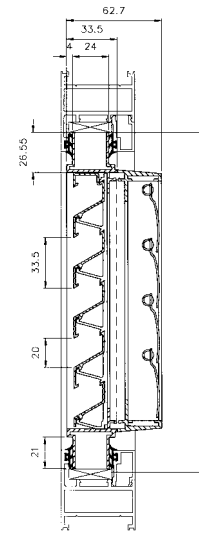

Controllable louvre

Material

- Made from aluminium sections: AlMgSi 0.5 (according to EN 12020-2)
- Stainless steel 304 mesh (2.3 x 2.3 mm) or insect screen (6 x 6 mm) on request
- Finishing: anodized in satin/bronze colour (20 micron) or powder-coated in any RAL or Syntha Pulvin colour (40 micron)

Dimensions

- Blade pitch: 33,3 mm
- Frame thickness: 24, 28 or 32 mm
- Minimum dimensions: 130x130 mm
- Specify on ordering: width x height in mm (overall dimensions)
- Controllable in combination with 100, 130 and 150 mm hit-and-miss ventilators or with insulated aluminium door (414/D) (max size 800 x 800 mm H)

Fixing

- Suitable for 24, 28, 32 mm glazing sections. Other thicknesses on request.

Control options (1 control panel per module)

- Standard: knob control
- Rod
- Cord
- Motor

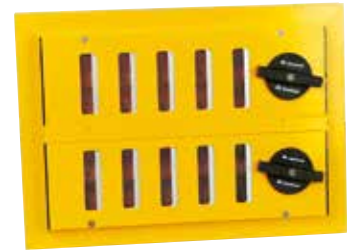

414VA



414/D

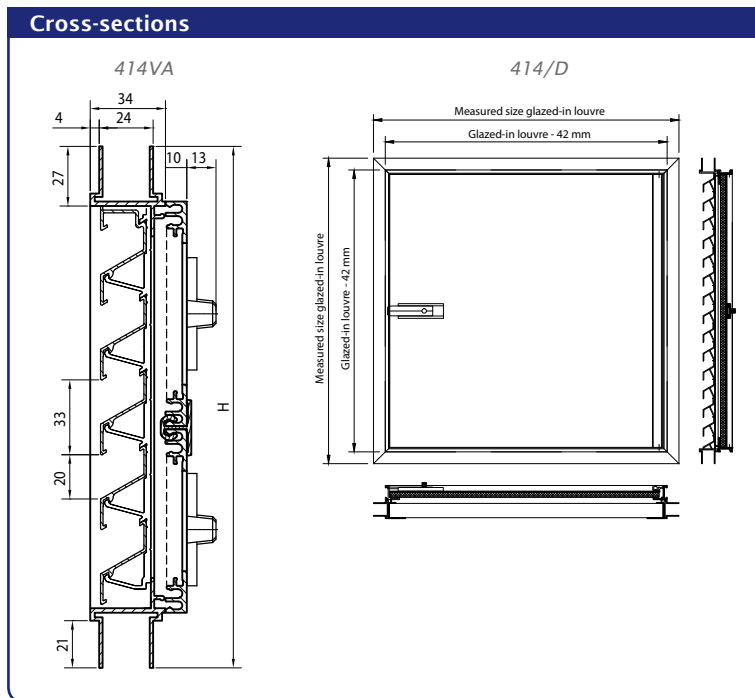

Technical specifications	
	414VA
Airflow	(EN 13030)
K-factor (supply)	28,13
C _e coefficient	0,189
<i>(For combination with 130 and 150 mm vents)</i>	



414THF < Glazed-in louvres

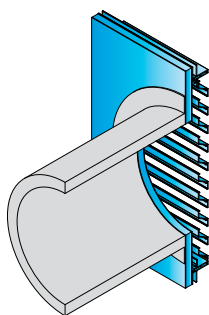
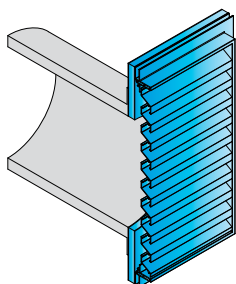

Thermally insulated window grille

Material

- Made from aluminium sections: AlMgSi 0.5 (according to EN 12020-2)
- Finishing: anodized in satin/bronze colour (20 micron) or powder-coated in any RAL or Syntha Pulvin colour (40 micron)
- Thermal insulation panel with PUR foam composite
- Sandwichpanel can also be powdercoated on both sides

Dimensions

- Blade pitch: 33,3 mm
- Minimum size: 130 x 130mm
- Flange width: 24, 28 and 32

Fixing

- Suitable for 24, 28, 32 mm glazing sections. Other thicknesses on request.

Typical applications

- Curtain walls
- Thermally insulated air duct

Cross-section

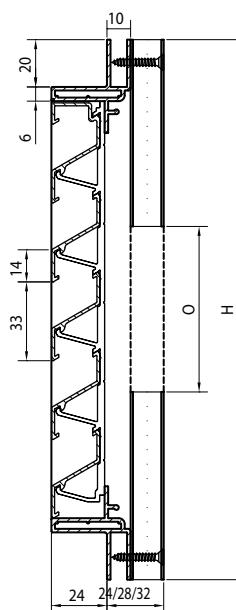

Technical specifications (for cut-out part of thermal insulation)

	414THF
Airflow	(EN 13030)
K-factor (supply)	23,56
K-factor (discharge)	25,51
C _e coefficient	0,206
C _d coefficient	0,198
Technical data	
Visual free area	59 %
U-value	1,1 W/m ² K

Glazed-in louvre with chevron section blades, pitch 20

Material

- Made from aluminium sections: AlMgSi 0.5 (according to EN 12020-2)
- Stainless steel 304 mesh (6 x 6 mm) or insect screen (2.3 x 2.3 mm) on request
- Finishing: anodized in satin/bronze colour (20 micron) or powder-coated in any RAL or Syntha Pulvin colour (40 micron)

Dimensions

- Blade pitch: 20 mm
- Frame thickness: 24, 28 or 32 mm
- Minimum dimensions: 130 x 130 mm
- Specify on ordering: width x height in mm (Overall dimensions)

Fixing

- Suitable for 24, 28, 32 mm glazing sections. Other thicknesses on request.

Opties

- Water channel
- Drainage profile
- Removable mesh
- filter

Typical applications

- Window Louvre with no look-through and stick-proof

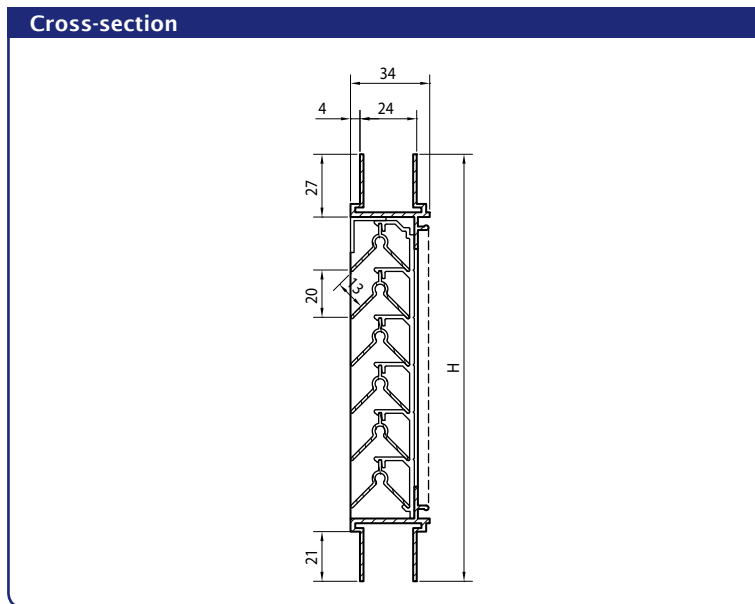

Technical specifications	
	415
Airflow	(EN 13030)
K-factor (supply)	33,80
K-factor (discharge)	33,80
C _e coefficient	0,172
C _d coefficient	0,172
Technical data	
Visual free area	93 %
Physical free area	39 %
IP class	IP2XD

415VA < Glazed-in louvres



Controllable louvre with chevron section blade

Material

- Made from aluminium sections: AlMgSi 0.5 (according to EN 12020-2)
- Stainless steel 304 mesh (6 x 6 mm) or insect screen (2.3 x 2.3 mm) on request
- Finishing: anodized in satin/bronze colour (20 micron) or powder-coated in any RAL or Syntha Pulvin colour (40 micron)

Dimensions

- Blade pitch: 20 mm
- Frame thickness: 24, 28 or 32 mm
- Specify on ordering: width x height in mm (overall dimensions)
- Controllable in combination with 100, 130 and 150 mm hit-and-miss ventilators or with insulated aluminium door (415/D)
- Minimum dimensions: 130 x 130 mm

Fixing

- Suitable for 24, 28, 32 mm glazing sections. Other thicknesses on request.

Control options (1 control panel per module)

- Standard: knob control
- Rod
- Cord
- Motor

Typical applications

- Classrooms



Cross-section

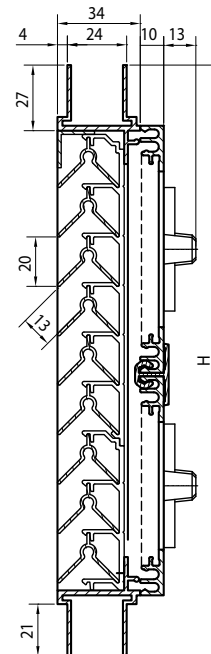

Technical specifications

	415VA
Airflow	(EN 13030)
K-factor (supply)	34,24
C _e coefficient	0,171
<i>(For combination with 100, 130 and 150 vents)</i>	

Glazed-in louvre, heavy-duty series, pitch 50

Material

- Made from aluminium sections: AlMgSi 0.5 (according to EN 12020-2)
- Stainless steel 304 insect screen (2.3 x 2.3 mm) or mesh (6 x 6 mm) on request
- Finishing: anodized in satin/bronze colour (20 micron) or powder-coated in any RAL or Syntha Pulvin colour (40 micron)

Dimensions

- Blade pitch: 50 mm
- Frame thickness: 24 or 28 mm
- Specify on ordering: full width x height in mm
- Minimum dimensions: 220 x 220 mm

Fixing

- Suitable for 24, 28, 32 mm glazing sections. Other thicknesses on request.

Options

- Water channel
- Drainage profile
- Removable mesh
- Filter

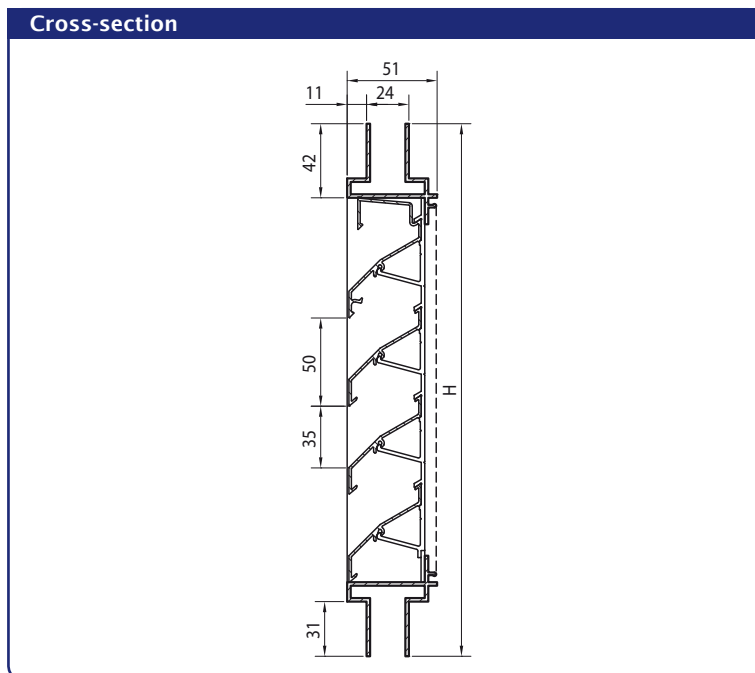

Technical specifications	
	424
Airflow	(EN 13030)
K-factor (supply)	12,57
K-factor (discharge)	8,91
C _e coefficient	0,282
C _d coefficient	0,335
Technical data	
Visual free area	70 %
Physical free area	49 %
IP class (louvre with mesh; electrical installation at least 105mm from louvre)	IP2XD

428 < Glazed-in louvres



Glazed-in louvre with chevron section blades, heavy-duty series, pitch 33

Material

- Made from aluminium sections: AlMgSi 0.5 (according to EN 12020-2)
- Stainless steel 304 insect screen (2.3 x 2.3 mm) or mesh (6 x 6 mm) on request
- Finishing: anodized in satin/bronze colour (20 micron) or powder-coated in any RAL or Syntha Pulvin colour (40 micron)

Dimensions

- Blade pitch: 33,3 mm
- Frame thickness: 24 or 28 mm
- Specify on ordering: full width x height in mm
- Minimum dimensions: 220 x 220 mm

Fixing

- Suitable for 24, 28, 32 mm glazing sections. Other thicknesses on request.

Options

- Water channel
- Drainage profile
- Removable mesh
- Filter

Cross-section

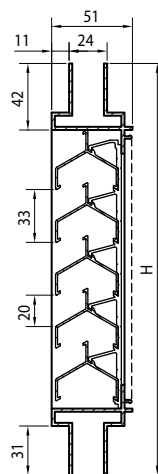

Technical specifications

	428
Airflow	(EN 13030)
K-factor (supply)	61,04
K-factor (discharge)	61,04
C _e coefficient	0,128
C _d coefficient	0,128
Technical data	
Visual free area	59 %
Physical free area	43 %

High-airflow glazed-in louvre, pitch 60

Material

- Made from aluminium sections: AlMgSi 0.5 (according to EN 12020-2)
- Stainless steel 304 mesh (6 x 6 mm) or insect screen (2.3 x 2.3 mm) on request
- Finishing: anodized in satin/bronze colour (20 micron) or powder-coated in any RAL or Syntha Pulvin colour (40 micron)

Dimensions

- Blade pitch: 60 mm
- Frame thickness: 24 mm (frame thickness of 8 to 50 mm on request)
- Specify on ordering: full width x height in mm
- Minimum dimensions: 385 x 385 mm

Fixing

- Suitable for 24, 28, 32 mm glazing sections. Other thicknesses on request.

Options

- Water channel
- Drainage profile
- Removable mesh
- Filter

Typical applications

- Applications with request for high air-flow

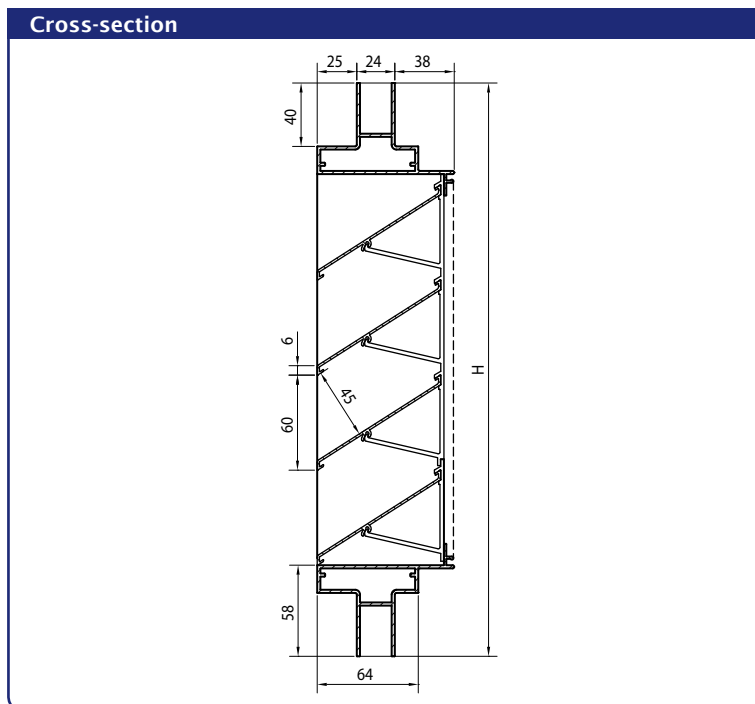

Technical specifications	
	483
Airflow	(EN 13030)
K-factor (supply)	5,59
K-factor (discharge)	5,62
C _e coefficient	0,423
C _d coefficient	0,422
Technical data	
Visual free area	90 %
Physical free area	76 %

484 < Glazed-in louvres



Glazed-in louvre, heavy-duty series, pitch 50

Material

- Made from aluminium sections: AlMgSi 0.5 (according to EN 12020-2)
- Stainless steel 304 insect screen (2.3 x 2.3 mm) or mesh (6 x 6 mm) on request
- Finishing: anodized in satin/bronze colour (20 micron) or powder-coated in any RAL or Syntha Pulvin colour (40 micron)

Dimensions

- Blade pitch: 50 mm
- Frame thickness: 24 or 28 mm
- Specify on ordering: full width x height in mm
- Minimum dimensions: 220 x 220 mm

Fixing

- Suitable for 24, 28, 32 mm glazing sections. Other thicknesses on request.

Options

- Water channel
- Removable mesh
- Filter
- Controllable type 484/VA - same build as type 414/VA

Cross-section

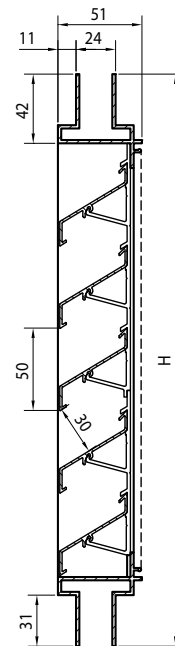

Technical specifications

	484
Airflow	(EN 13030)
K-factor (supply)	8,75
K-factor (discharge)	8,45
C _e coefficient	0,338
C _d coefficient	0,344
Technical data	
Visual free area	70 %
Physical free area	60 %
IP class (louvre with mesh; electrical installation at least 100mm from louvre)	IP2XD

Glazed-in "storm" louvre, pitch 33

Material

- Made from aluminium sections: AlMgSi 0.5 (according to EN 12020-2)
- Stainless steel 304 mesh (6 x 6 mm) or insect screen (2.3 x 2.3 mm) on request
- Finishing: anodized in satin/bronze colour (20 micron) or powder-coated in any RAL or Syntha Pulvin colour (40 micron)

Dimensions

- Blade pitch: 33,3 mm
- Frame thickness: 24, 28 or 32 mm
- Specify on ordering: full width x height in mm
- Minimum dimensions: 130 x 130 mm

Fixing

- Suitable for 24, 28, 32 mm glazing sections. Other thicknesses on request.

Options

- Water channel
- Drainage profile
- Removable mesh
- Filter
- Welded blades on frame

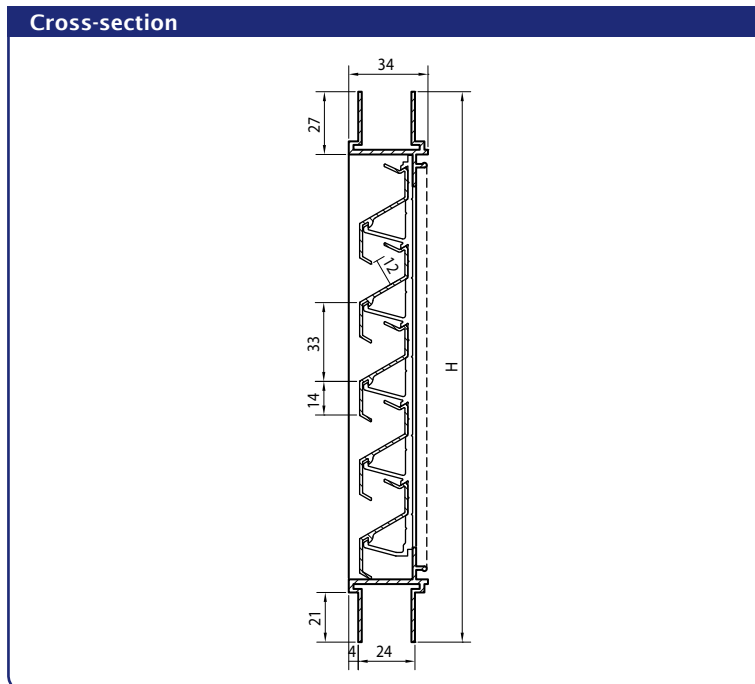

AIRFLOW

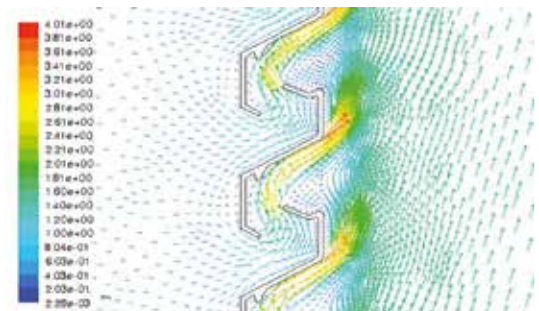

Supply

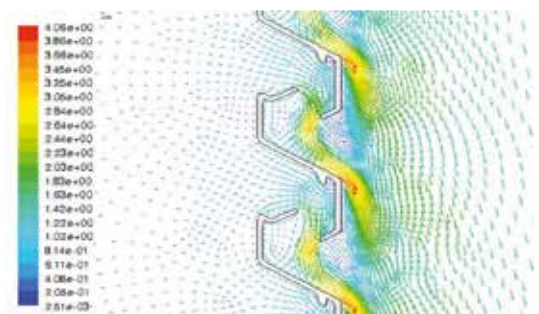

Discharge

Technical specifications	
	494
Airflow	(EN 13030)
K-factor (supply)	123,5
K-factor (discharge)	118,1
C _e coefficient	0,090
C _d coefficient	0,092
Technical data	
Visual free area	57 %
Physical free area	26 %



425GL < Glazed-in louvres



Glazed-in louvre, extra-heavy-duty series

Material

- Made from aluminium sections: AlMgSi 0.5 (according to EN 12020-2)
- Stainless steel 304 mesh (6 x 6 mm) or insect screen (2.3 x 2.3 mm) on request
- Finishing: anodized in satin/bronze colour (20 micron) or powder-coated in any RAL or Syntha Pulvin colour (40 micron)

Dimensions

- Blade pitch: 95 mm
- Depth to fit: 81.5 mm
- Frame thickness: 24 mm (frame thickness of 8 to 50 mm on request)
- Specify on ordering: full width x height in mm
- Minimum dimensions: 385 x 385 mm

Fixing

- Suitable for 24, 28, 32 mm glazing sections. Other thicknesses on request.

Options

- Water channel
- Drainage profile
- Removable mesh
- Filter

Cross-section

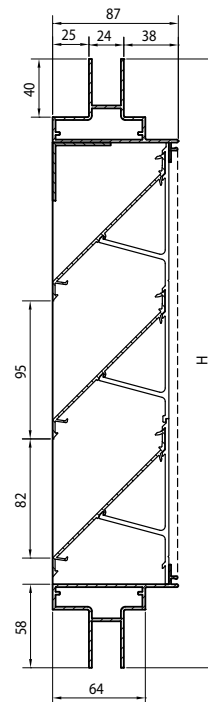

Technical specifications

	425GL
	(EN 13030)
Airflow	
K-factor (supply)	11,41
K-factor (discharge)	11,65
C _e coefficient	0,296
C _d coefficient	0,293
Technical data	
Visual free area	86 %
Physical free area	55 %

Glazed-in louvre with adjustable blades, extra-heavy-duty series

Material

- Made from aluminium sections: AlMgSi 0.5 (according to EN 12020-2)
- Stainless steel 304 mesh (6 x 6 mm) or insect screen (2.3 x 2.3 mm) on request
- Finishing: anodized in satin/bronze colour (20 micron) or powder-coated in any RAL or Syntha Pulvin colour (40 micron)

Dimensions

- Blade pitch: 95 mm
- Height = (number of blades x 100) + 177 mm
- Maximum width in one piece: 1300 mm
- Frame thickness: 24 mm (frame thickness of 8 to 50 mm on request)
- Specify on ordering: full width x height in mm
- Minimum dimensions: 385 x 385 mm

Fixing

- Suitable for 24, 28, 32 mm glazing sections. Other thicknesses on request.

Control options

- Manual 427/1
- Cable 427/2
- Ultraflex 427/3
- Motor 427/4
- Air pressure 427/5

For more information on the different control modes, please refer to page 18.

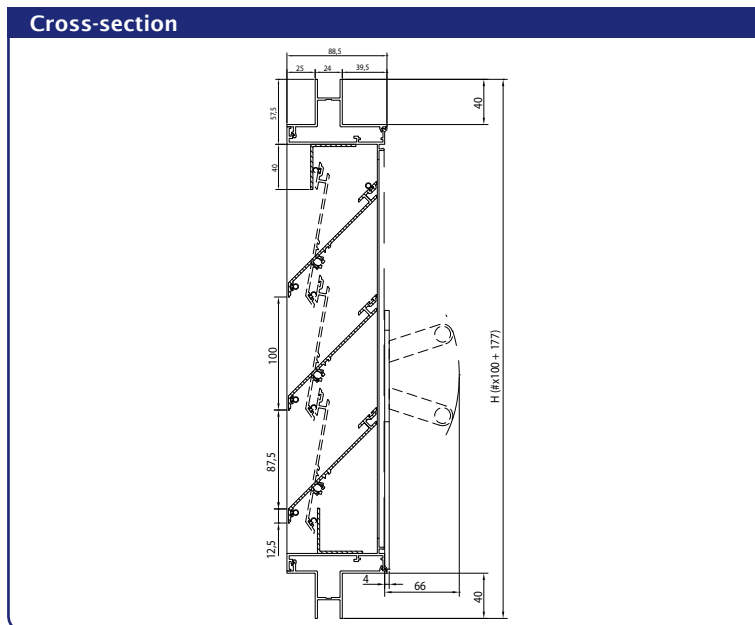

Technical specifications	
	427GL
Airflow	(EN 13030)
K-factor (supply)	11,41
K-factor (discharge)	11,65
C _e coefficient	0,296
C _d coefficient	0,293
Technical data	
Visual free area	86 %
Physical free area	53 %



Acoustic wall louvre

Material

- Made from aluminium sections: AlMgSi 0.5 (according to EN 12020-2)
- Stainless steel 304 mesh (6 x 6 mm) or insect screen (2.3 x 2.3 mm) on request
- Finishing: anodized in satin/bronze colour (20 micron) or powder-coated in any RAL or Syntha Pulvin colour (40 micron)
- 100% stainless

Dimensions

- Blade pitch: 60 mm
- Dimensions: depth to fit: 81.5mm
- Frame thickness: 50mm
- Height in steps of 60 mm (space between blades)
- Minimum dimensions: 300x300mm

Fixing

- Brackets ref. 429

Options

- Water channel
- Drainage profile
- Removable mesh

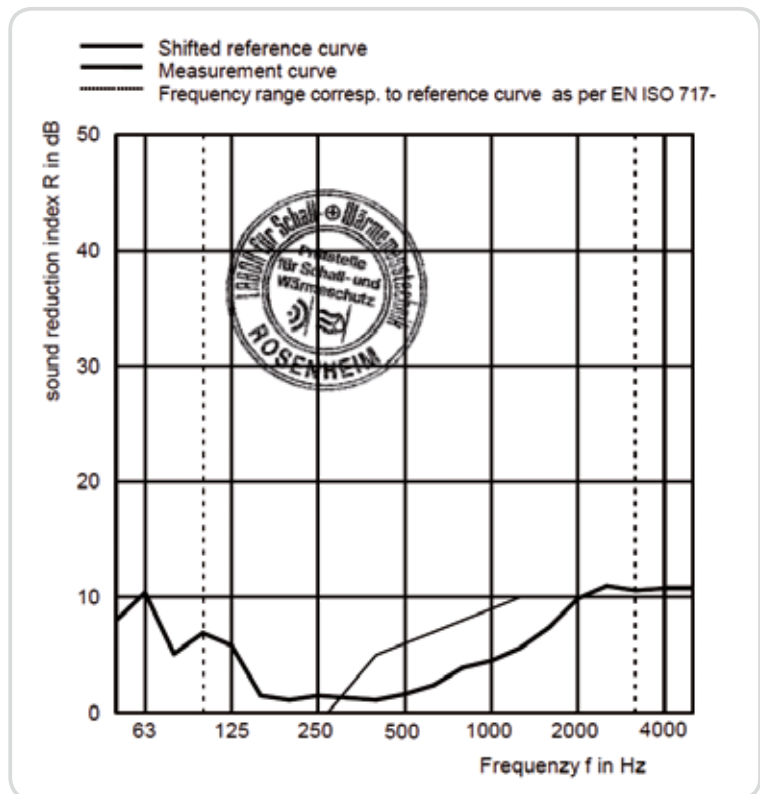

The acoustic properties of the RENSON®-blades have been tested by the internationally recognized laboratory, IFT Lab Rosenheim (Germany)



Cross-section

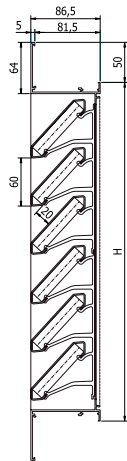

Technical specifications

445/86	
Airflow	(EN 13030)
K-factor (supply)	9,22
K-factor (discharge)	13,29
C _e coefficient	0,329
C _d coefficient	0,274
Comfort	(EN ISO 140-10, EN ISO 717-1)
Sound reduction in open position R _w (C;C _{tr})	6 (-1;-2) dB
Technical data	
Visual free area	77 %
Physical free area	34 %
Depth to fit	86 mm

Sound reduction in dB per frequency

445/86	
f in Hz	R in dB
63	10,4
125	5,8
250	1,5
500	1,6
1000	4,5
2000	9,9
4000	10,8

446/150, 446/225, 446/300 < Acoustic louvres



446/150

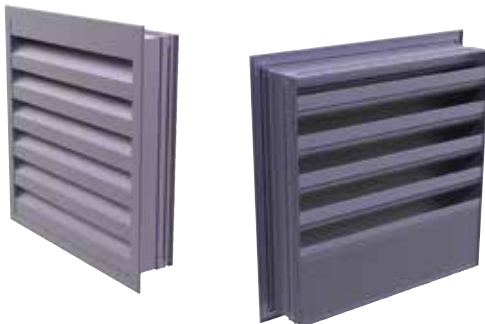

446/225



446/300

Acoustic wall louvre, blade pitch 150 mm

Material

- Aluminum profiles AlMgSi 0,5 (according to EN 12020-2)
- Acoustic insulation material: non-flammable mineral wool
- Stainless steel mesh 304 6x6mm
- Finishing: anodized in satin/bronze colour (20 micron) or powder-coated in any RAL or Syntha Pulvin colour (40 micron)
- 100% stainless

Dimensions

- Blade pitch: 150 mm
- Depth to fit: 150mm
- Frame thickness: 55mm
- Height in steps of 150 mm (space between blades)
- Minimum dimensions: 300x410mm H

Fixing

- Fixing bracket: installation with bracket no. 1428 possible
 - position 1: up to 100 mm wall thickness
 - position 2: for wall thickness up to 200 mm
- Screws: Fix the screws from the outside through the flange (screw holes upon request)
- Pull bracket: fixation with a long pull bracket and expander bolts for wall mounting or a short pull bracket for connection to a ventilation channel (pull bracket rod optional)
- Fixation on the backside: by screwing a hammerhead bolt to a structural backframe.
- For louvres 446/300 larger than 3m², a backframe structure is required

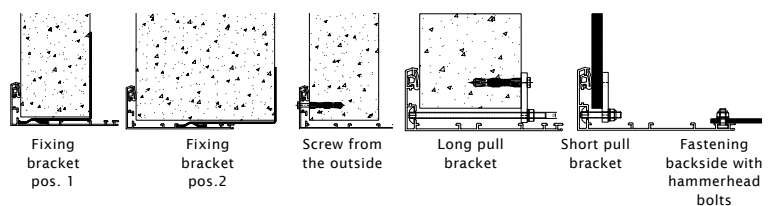

Sealing possibilities

- Sealing gasket: suitable for reduction of contact sounds (option sealing gasket)
- PU sealing tape: against water infiltration (option PU sealing tape)
- Silicone seal: seal the flange on the outside with silicone. (option silicone)

Options

- Drainage profile

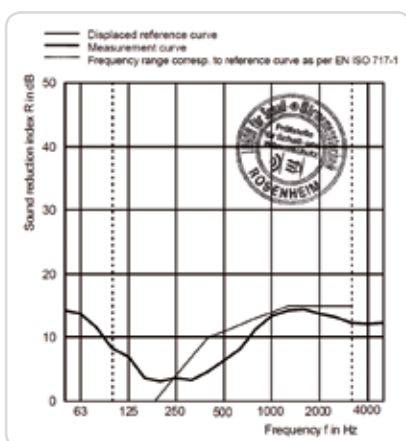

446/150

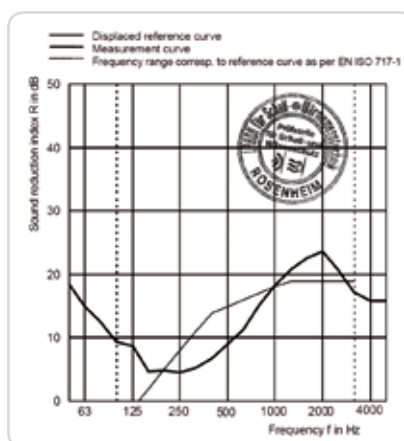

446/225

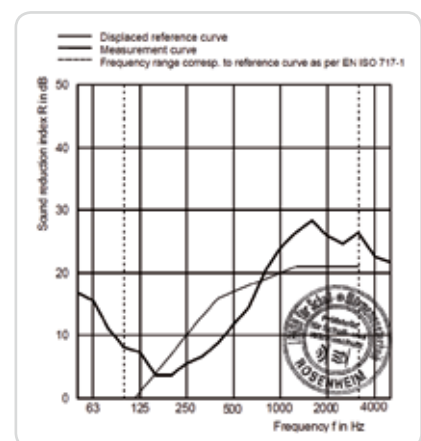

446/300

Acoustic louvres > 446/150, 446/225, 446/300

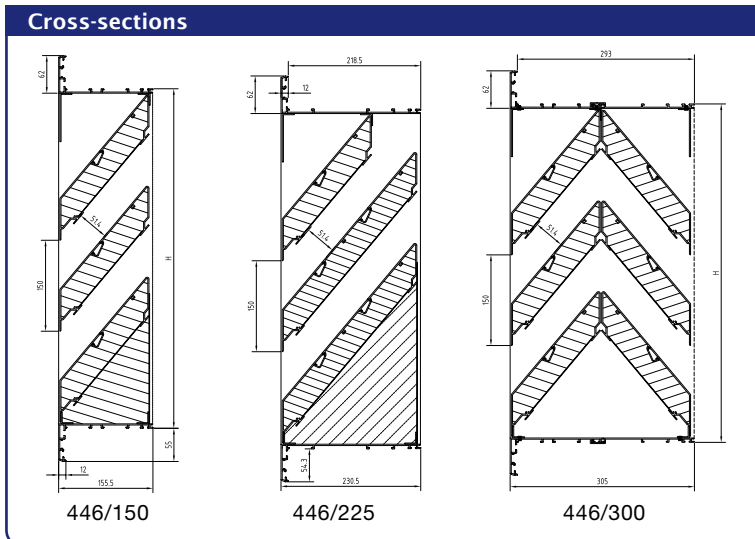

Technical specifications			
	446/150	446/225	446/300
Airflow		(EN 13030)	
K-factor (supply)	38,46	37,30	45,93
K-factor (discharge)	34,48	41,90	45,93
C _s coefficient	0,161	0,164	0,148
C _d coefficient	0,169	0,150	0,148
Comfort		(EN ISO 140-10, EN ISO 717-1)	
Sound reduction in open position R _w (C;C _{tr})	11 (-1;-2) dB	15 (-1;-4) dB	17 (-1;-4) dB
Technical data			
Visual free area	54 %	54 %	54 %
Physical free area	34,3 %	34,3 %	34,3 %
Watertightness	A (1 m/s)	A (1 m/s)	A (1 m/s)
Depth to fit	150 mm	225 mm	300 mm

Sound reduction in dB per frequency			
	446/150	446/225	446/300
f in Hz	R in dB	R in dB	R in dB
63	13,8	15,0	15,7
125	6,9	8,7	7,3
250	3,6	4,5	5,5
500	6,4	9,1	11,8
1000	13,4	18,2	24,0
2000	13,8	23,7	25,9
4000	12,1	15,8	22,6

The acoustic properties of the RENSON®-blades have been tested by the internationally recognized laboratory, IFT Lab Rosenheim (Germany)



Water resistance tested by BSRIA laboratories.



447/150, 447/225 < Acoustic louvres

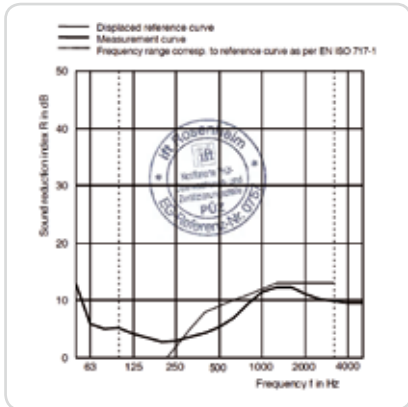

447/150

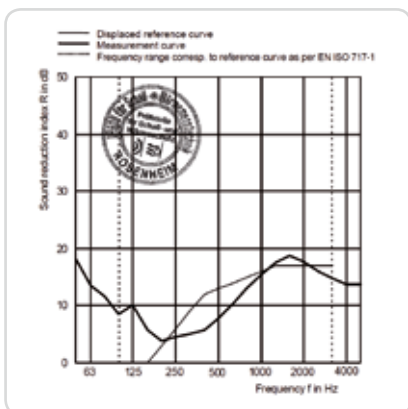

447/225

Acoustic wall louvre, blade pitch 170 mm

Material

- Aluminum profiles AlMgSi 0,5 (according to EN 12020-2)
- Acoustic insulation material: non-flammable mineral wool
- Stainless steel mesh 304 6x6mm
- Finishing: anodized in satin/bronze colour (20 micron) or powder-coated in any RAL or Syntha Pulvin colour (40 micron)

Dimensions

- Blade pitch: 170 mm
- Depth to fit: 150mm
- Frame thickness: 55mm
- Height in steps of 150 mm (space between blades)
- Minimum dimensions: 300x410mm H
- Fixing bracket: installation with bracket no. 1428 possible
 - position 1: up to 100 mm wall thickness
 - position 2: for wall thickness up to 200 mm
- Screws: Fix the screws from the outside through the flange (screw holes upon request)
- Pull bracket: fixation with a long pull bracket and expander bolts for wall mounting or a short pull bracket for connection to a ventilation channel (pull bracket rod optional)
- Fixation on the backside: by screwing a hammerhead bolt to a structural backframe.

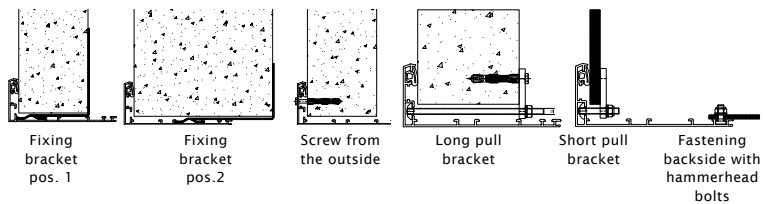

Sealing possibilities

- Sealing gasket: suitable for reduction of contact sounds (option sealing gasket)
- PU sealing tape: against water infiltration (option PU sealing tape)
- Silicone seal: seal the flange on the outside with silicone. (option silicone)

Options

- Drainage profile



The acoustic properties of the RENSON®-blades have been tested by the internationally recognized laboratory, IFT Lab Rosenheim (Germany)



Cross-sections

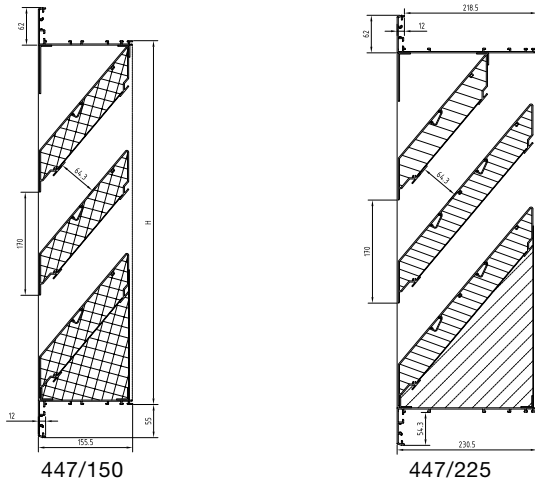

Detaildoorsnede

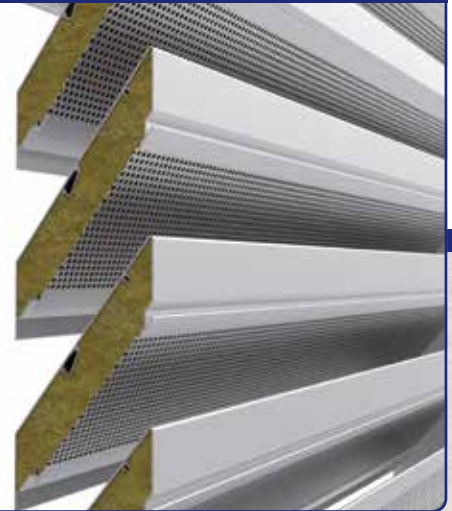

Technical specifications

	447/150	447/225
Airflow	(EN 13030)	
K-factor (supply)	25,46	28,58
K-factor (discharge)	25,15	30,88
C _e coefficient	0,198	0,187
C _d coefficient	0,200	0,180
Comfort	(EN ISO 140-10, EN ISO 717-1)	
Sound reduction in open position R _w (C;C _w)	9 (0;-1) dB	13 (-1;-3) dB
Technical data		
Visual free area	59 %	59 %
Physical free area	37 %	37 %
Depth to fit	150 mm	225 mm

Sound reduction in dB per frequency

	447/150	447/225
f in Hz	R in dB	R in dB
63	5,9	13,6
125	4,2	10,1
250	2,9	4,6
500	5,4	7,8
1000	11,5	15,4
2000	11,2	17,8
4000	9,6	13,7

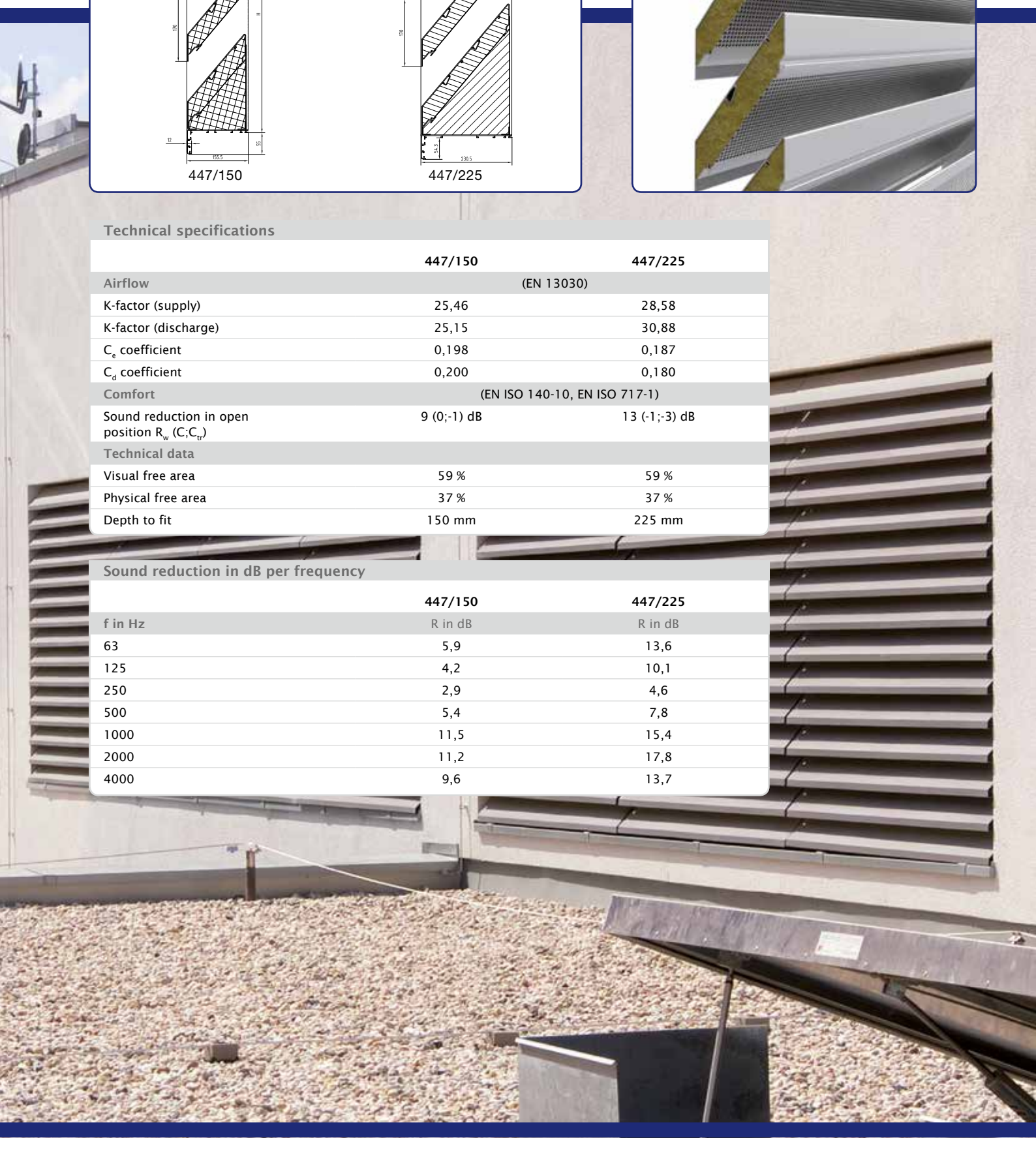

468AK/1 < Acoustic louvres



468AK/1 - front view



468AK/1 - rear view



Interior acoustic wall louvre

Material

- Made from aluminium sections: AlMgSi 0.5 (according to EN 12020-2)
- Finishing: anodized in satin/bronze colour (20 micron) or powder-coated in any RAL or Syntha Pulvin colour (40 micron)
- Sound absorbing material: synthetic foam
- Labyrinth type blades

Dimensions

- Blade pitch: 85 mm
- Minimum dimensions: 200 x 181 mm H
- Maximum dimensions: 776 x 776 mm H
- Fitting dimensions: 7 mm more than the louvre dimensions.
- Height in 85 mm steps (blade pitch)
- Depth to fit: 48 mm
- Flange size: 30 mm

Available models

- The 468 AK/1 is always made to measure, up to a maximum size of 776 x 776 mm.

Typical applications

- Schools
- Hospitals
- Elderly homes

Cross-section

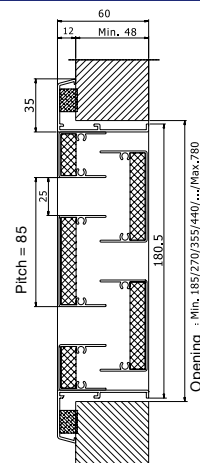

Technical specifications

		447/150	
Airflow	(EN 13030)	Comfort - $D_{n,e,w}$ ($C;C_{tr}$)	
K-factor (supply)		86,85	
K-factor (discharge)		89,35	
C_e coefficient		0,107	
C_d coefficient		0,106	
Q at 2 Pa – louvre 292 x 193 mm	25 m ³ /h	30 (-1;-2) dB	
Q at 2 Pa – louvre 382 x 278 mm	50 m ³ /h	28 (-1;-2) dB	
Q at 2 Pa – louvre 432 x 363 mm	75 m ³ /h	26 (-1;-2) dB	
Q at 2 Pa – louvre 452 x 448 mm	100 m ³ /h	25 (-1;-2) dB	
Comfort		(EN ISO 140-10, EN ISO 717-1)	
Sound reduction in open position R_w ($C;C_{tr}$) R_w ($C;C_{tr}$)		8 (-1;-2) dB	
Technical data			
Visual free area		29 %	
Physical free area		29 %	
Ip class (louvre with mesh)		IP2XD	

Burglarproof louvre class WK2

Material

- Made from aluminum profiles AlMgSi 0.5 (according to EN 12020-2)
- Stainless steel insect mesh 304 - 2.3 x 2.3 mm or stainless steel mesh 304 6 x 6 mm upon request
- Finishing: anodized in satin/bronze colour (20 micron) or powder-coated in any RAL or Syntha Pulvin colour (40 micron)

Dimensions

- Blade pitch: 50 mm
- Depth: 46 mm
- Flange size: 40 mm
- Minimum dimensions: 200 x 200 mm

Options

- Water channel
- Drainage profile

Features

- Aesthetical and functional high-quality louvre:
 - Burglarproof according to class WK2, certificate surface $0.44 < \alpha < 1.225 \text{ m}^2$, in accordance to prEN 1627 till 1630 (May 2009)
- Easy to install using brackets.
- 100% stainless:
 - Entirely assembled of aluminum profiles
 - All connecting pieces in aluminum and stainless steel

Typical applications

- Applications that should be low-level burglarproof like schools and shops
- Apartmentblocks



AIRFLOW

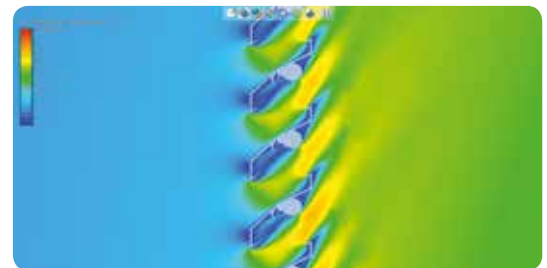

Supply

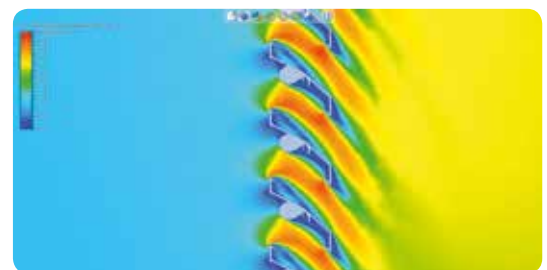

Discharge

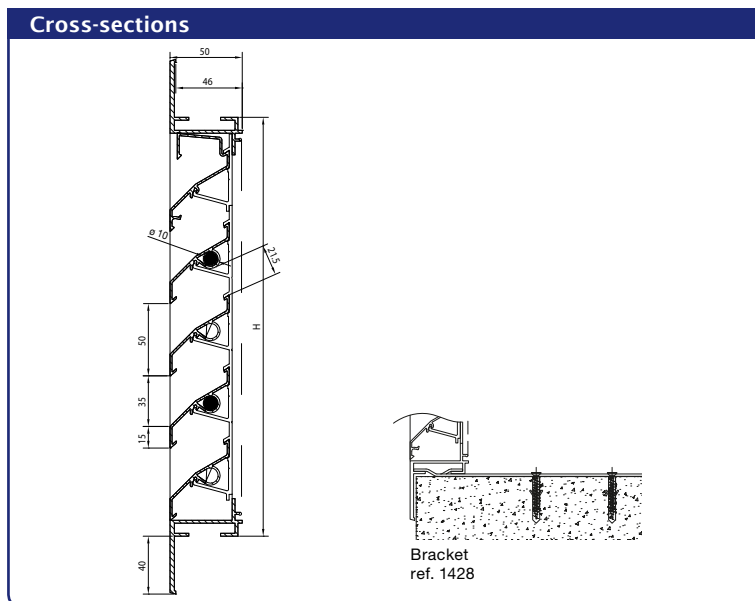

Technical specifications	
	421WK2
Airflow	(EN 13030)
K-factor (supply)	13,82
K-factor (discharge)	12,85
C _e coefficient	0,269
C _d coefficient	0,279
Technical data	
Visual free area	70 %
Physical free area	43 %
Aesthetically identical to the standard louvre 421	

431WK2 < Burglarproof louvres



Burglarproof louvre class WK2

Material

- Made from aluminum profiles AlMgSi 0.5 (according to EN 12020-2)
- Stainless steel insect mesh 304 - 2.3 x 2.3 mm or stainless steel mesh 304 6 x 6 mm upon request
- Finishing: anodized in satin/bronze colour (20 micron) or powder-coated in any RAL or Syntha Pulvin colour (40 micron)

Dimensions

- Blade pitch: 33,3 mm
- Thickness: 31 mm
- Minimum dimensions: 200 x 200 mm

Fixing

- By means of burglarproof screws type SecuFast® Pin Hexagon diam. 4,2 x 38 mm A2 (included)



Features

- Aesthetical and functional high-quality louvre:
 - Burglarproof according to class WK2, certificate surface 0.44 <math><0</math> <math><1.225\text{ m}^2</math>, in accordance with prEN 1627 till 1630 (May 2009)
- 100% stainless:
 - Entirely assembled of aluminum profiles
 - All connecting pieces in aluminum and stainless steel

Typical applications

- Stainless steel insect mesh 304 2.3 x 2.3 mm as standard (6 x 6 mm available on request)

Cross-section

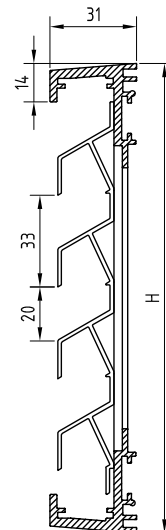

Technical specifications

	431WK2
Airflow (EN 13030)	
K-factor (supply)	23,56
K-factor (discharge)	25,51
C _e coefficient	0,206
C _d coefficient	0,198
Technical data	
Visual free area	59 %
Physical free area	40,5 %
Aesthetically identical to the standard louvre 431	

Burglarproof louvre class WK4

Material

- Made from aluminum profiles AlMgSi 0.5 (according to EN 12020-2)
- Stainless steel insect mesh 304 - 2.3 x 2.3 mm or stainless steel mesh 304 6 x 6 mm upon request
- Finishing: anodized in satin/bronze colour (20 micron) or powder-coated in any RAL or Syntha Pulvin colour (40 micron)

Dimensions

- Blade pitch: 50 mm
- Depth: 50 mm
- Frame without flange
- Minimum dimensions: 200 x 200 mm
- Every second blade has a bi-chromatised steel bar of diam. 20 mm.

Fixing

- The steel bars of the louvre need to be incorporated in the wall.
- Frame without flange

Options

- Water channel
- Filter

Features

- Aesthetical and functional high-quality louvre:
 - Burglarproof class WK4, in accordance with prEN 1627 till 1630 (May 2009).
 - Official test report No. DE78A982

Typical applications

- Banks, IT rooms, museums and diamond shops.

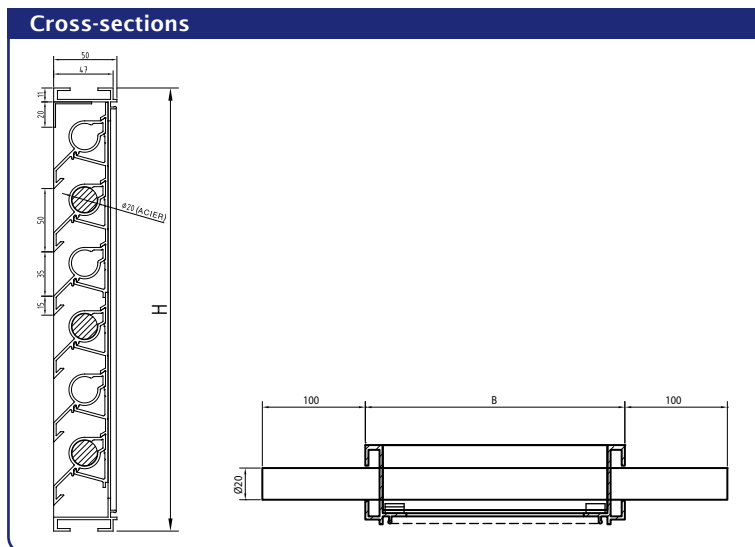

Technical specifications	
	423
Airflow	(EN 13030)
K-factor (supply)	27,06
K-factor (discharge)	27,28
C _e coefficient	0,193
C _d coefficient	0,192
Technical data	
Visual free area	70 %
Physical free area	22 %
IP class	IP2XD

440 < Louvre box

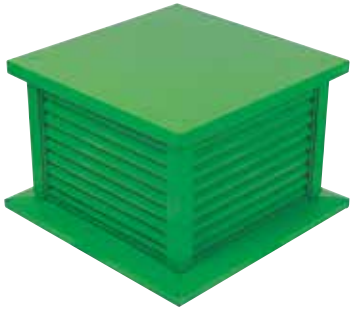

Turret

Material

- Made from aluminium sections: AlMgSi 0.5 (according to EN 12020-2)
- Finishing: anodized in satin/bronze colour (20 micron) or powder-coated in any RAL or Syntha Pulvin colour (40 micron)
- Cover plate
 - In aluminium sheet
 - Acoustic version optional

Dimensions

- Maximum dimensions in one piece up to 4m² ground surface
- Larger sizes possible on request

Types

All blade types possible, for example:

440/11: with blade n° 8 of louvre 411

440/21: with blade n° 17 of louvre 421

Cross-sections

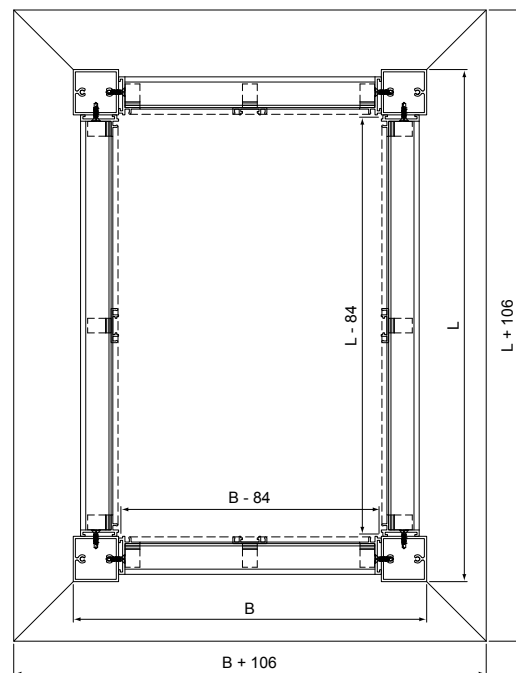
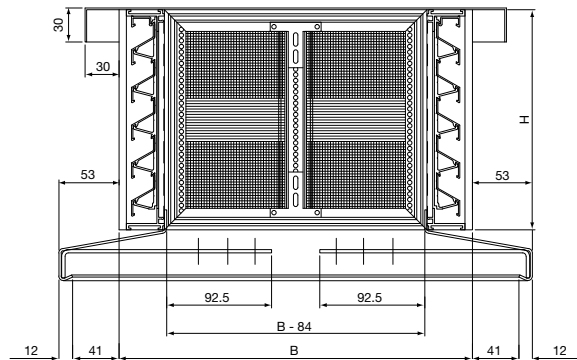

Cavity wall ventilator

Material

- Made from aluminium sections: AlMgSi 0.5 (according to EN 12020-2)
- Stainless steel 304 insect screen (2.3 x 2.3 mm)
- Finishing: anodized in satin/bronze colour (20 micron) or powder-coated in any RAL or Syntha Pulvin colour (40 micron)
- Connecting sleeve made from galvanised steel

Dimensions

- Size to fit: 265 x 90 mm (L x H)
- Flange size: 21 mm
- Controllable internal louver
- Adjustable sleeve for wall thickness of 24.5 to 40 cm

Options

- Optional sound absorbing material

Fixing

- Spring clips are included

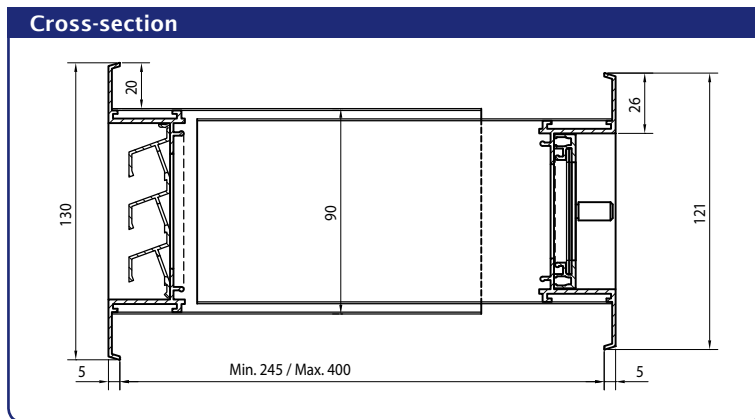

Stock models					
Dimensions length x height (L) x (H)	Satin anodised	RAL 9010	Airway opening in cm ²	Airflow at 2 Pa in m ³ /h	Airflow at 20 Pa in m ³ /h
265 x 90 mm	•	•	38	15	49,4

441 < Controllable cavity wall louvres



Register with frame

Material

- Made from aluminium sections: AlMgSi 0.5 (according to EN 12020-2)
- Stainless steel 304 insect screen (2.3 x 2.3 mm)
- Finishing: anodized in satin/bronze colour (20 micron) or powder-coated in any RAL or Syntha Pulvin colour (40 micron)

Dimensions

- Depth to fit: 28.5 mm
- Flange size: 21 mm
- Rotating knob for louvre lengths of 500 mm and above (possibility of pull-cord or rod operation)

Fixing

- Spring clips available on request

Stock models

Dimensions length x height (L) x (H)	Satin anodised	RAL 9010	Airway opening in cm ²	Airflow at 2 Pa in m ³ /h
217 x 212 mm	•	•	113	34
248 x 212 mm	•	•	140	38
307 x 312 mm	•	•	260	87

Cross-sections

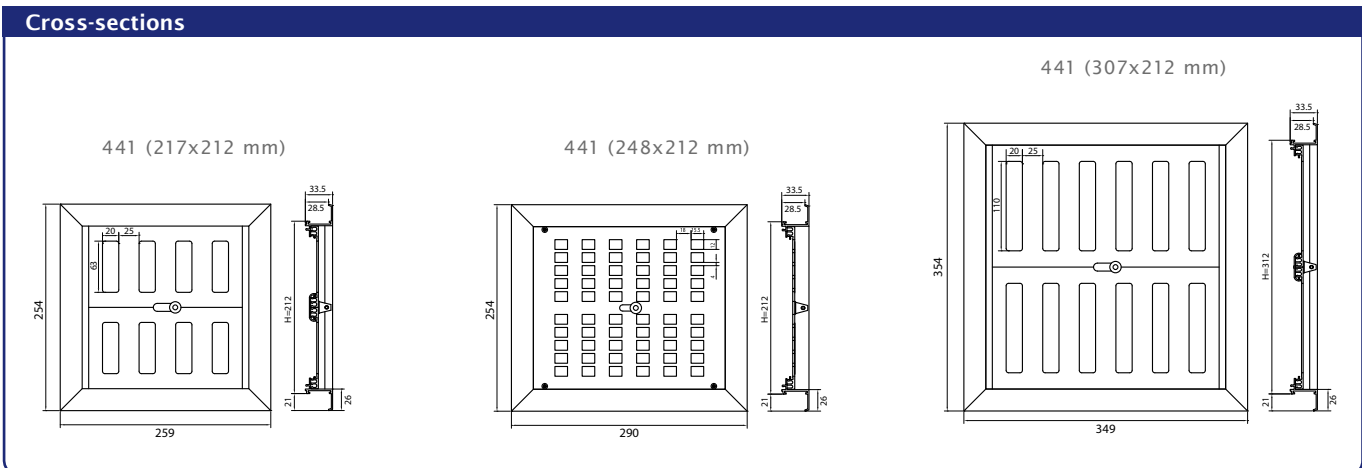

Register to fix

Material

- Made from aluminium sections: AlMgSi 0.5 (according to EN 12020-2)
- Stainless steel 304 insect screen (2.3 x 2.3 mm)
- Finishing: anodized in satin/bronze colour (20 micron) or powder-coated in any RAL or Syntha Pulvin colour (40 micron)

Dimensions

- Slide knob control
- Rotating knob for louvre lengths of 500 mm and above (possibility of pull-cord operation)
- Special heights on request
- The louvre height must fit within 100, 130 or 150 mm modules

Fixing

- Screws and plugs are included



Stock models				
Dimensions length x height (L) x (H)	Satin anodised	RAL 9010	Airway opening in cm ²	Airflow at 2 Pa in m ³ /h
4032/1: 175 x 150 mm	•	•	49	17,6
4032/2: 240 x 200 mm	•	•	113	40,7
4032/3: 325 x 300 mm	•	•	260	93,6
4032/4: 300 x 100 mm	•	•	68	24,5
4032/5: 450 x 100 mm	•	•	113	40,7

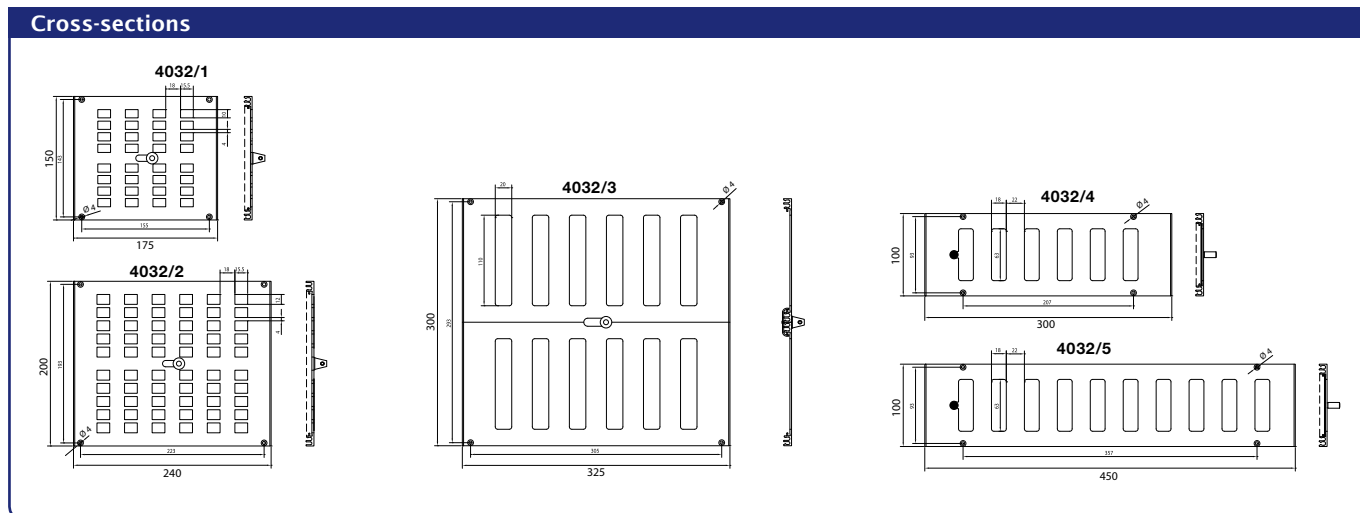

XD < Controllable cavity wall louvres

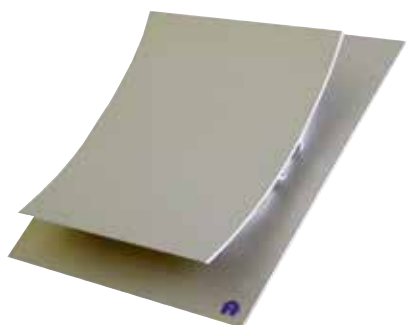

Stylish extraction louvre

Material

- Cover plate: aluminium AlMgSi 0.5 (according to EN 12020-2)
- Finishing: powder coating in any RAL or Syntha Pulvin® colour (40 microns)
- Base and sliding part: POM (polyoxymethylene)

Dimensions

- XD1: 152 x 152 mm
- XD2: 188 x 188 mm
- XD3: 233 x 233 mm
- Depth (in closed position): 79 mm

Available models

Three models are available:

- XD1 for mechanical extraction
- XD2 and XD3 for natural extraction, available in R AL 9006 or 9010 matt (standard colours).

Typical applications

- Aesthetical internal louvre for wall or ceiling



Cross-sections

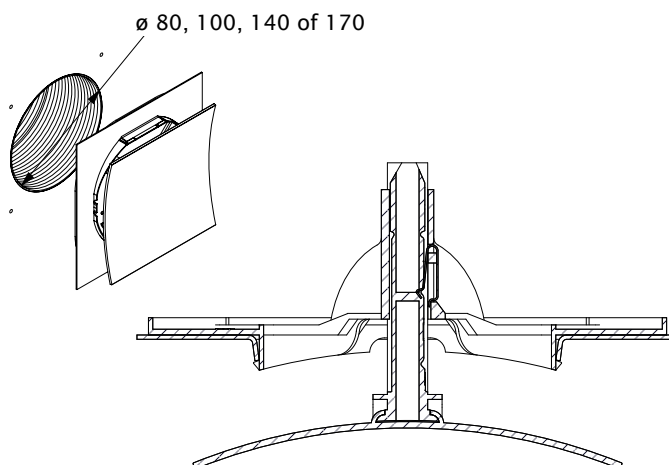

Technical specifications			
	XD1	XD2	XD3
Use	System C all wet areas	System A Toilet Closed area ≤ 14 m ²	System A Openspace kitchen Close area ≤ 14 m ²
Airflow		(EN 13141-1)	
	<i>Position II:</i> 22 m ³ /h at 2 Pa	<i>Position I:</i> 39,2 m ³ /h at 2 Pa <i>Position II:</i> 50,4 m ³ /h at 2 Pa	<i>Position I:</i> 63,0 m ³ /h at 2 Pa <i>Position II:</i> 87,1 m ³ /h at 2 Pa
Duct diameter	80 mm (max ø 140 mm)	100 mm, 140 mm (max ø 160 mm)	140 mm, 170 mm (max ø 200 mm)

Circular built-in punched grille

Material

- Made from punched aluminium sheet
- Finishing: powder-coated in white (RAL 9010), brown (RAL 8019) and aluminium (RAL 9006) colours (40 microns)
- Insect mesh included

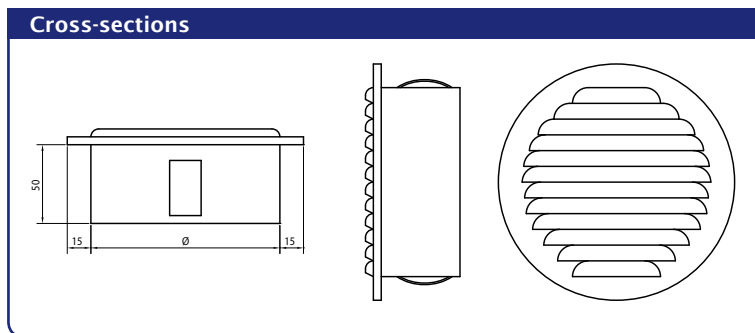

Stock models						
Diameter	RAL 9010	RAL 8019	RAL 9006	Airway opening in cm ²	Airflow at 2 Pa in m ³ /h	
Ø 80 mm	•	•	•	27	8,3	
Ø 100 mm	•	•	•	51	15,2	
Ø 115 mm	•	•	•	75	23,6	
Ø 145 mm	•	•	•	119	35,2	
Ø 190 mm	•	•	•	204	53,1	
Ø 245 mm	•	•	•	339	74,0	

436 < Punched grilles



Punched grille

Material

- Punched aluminium sheet
- Without insect mesh

Fixing

- Screw-mounted (screws and plugs not provided)

Cross-section

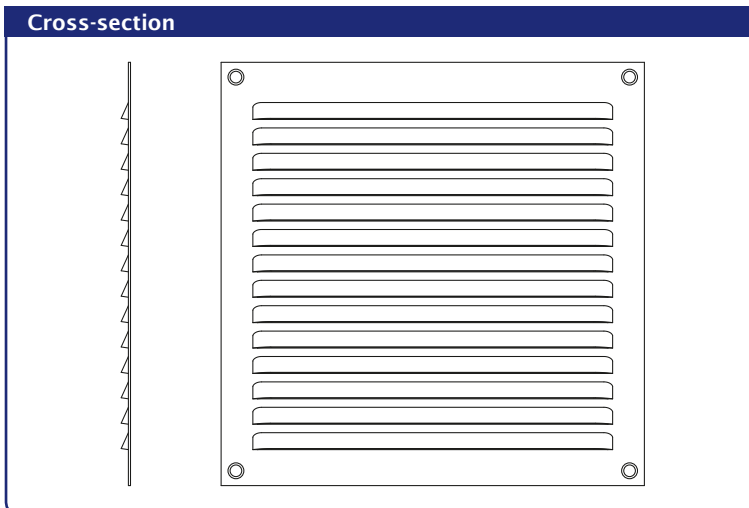

Stock models

Dimensions (L x H)	F1	RAL 9010	RAL 8019	Airflow at 2 Pa m ³ /h
150 x 150	•	•	•	16 m ³ /h
150 x 200	•	•	•	21,9 m ³ /h
200 x 100	•	•	•	12 m ³ /h
200 x 200	•	•	•	22,1 m ³ /h
200 x 250	•	•	•	36,7 m ³ /h
250 x 100	•	•	•	18,5 m ³ /h
250 x 250	•	•	•	46,6 m ³ /h
300 x 100	•	•	•	20,2 m ³ /h
300 x 300	•	•	•	73,5 m ³ /h
400 x 100	•	•	•	28,8 m ³ /h
400 x 400	•	•	•	86,4 m ³ /h
500 x 500	•	•	•	125,9 m ³ /h

Built-in ventilation grille

Fixing

- Made from aluminium sections: AlMgSi 0.5 (according to EN 12020-2)

Typical applications

- Kitchens, refrigerators, counters

Packaging quantity: 10 pieces

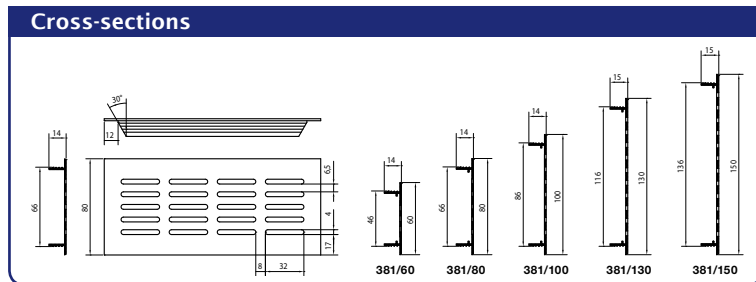
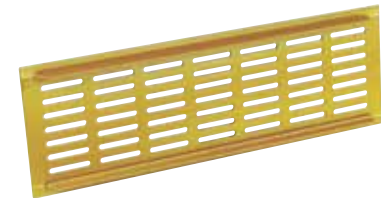
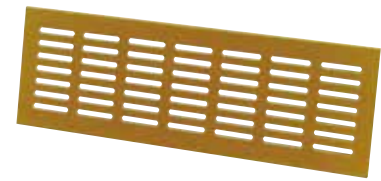

Stock models						
Dimensions length x height (L) x (H)	Satin anodised	Gold anodised	Ral 9010	RAL 8022	RAL 9005	Net free area cm ²
400 x 60 mm	•		•	•		44
500 x 60 mm	•		•	•		59
2000 x 60 mm	•		•	•		244
300 x 80 mm	•	•	•	•		43
400 x 80 mm	•	•	•	•	•	56
500 x 80 mm	•	•	•	•	•	74
600 x 80 mm	•	•	•	•		87
1000 x 80 mm	•		•	•		149
2000 x 80 mm	•	•	•	•		305
300 x 100 mm	•		•	•		61
400 x 100 mm	•	•	•	•		78
500 x 100 mm	•	•	•	•		104
600 x 100 mm	•		•	•		122
1000 x 100 mm	•		•	•		209
2000 x 100 mm	•	•	•	•		427
500 x 130 mm	•		•	•		149
1000 x 130 mm	•		•	•		298
2000 x 130 mm	•		•	•		610
500 x 150 mm	•		•	•		179
2000 x 150 mm	•	•	•	•		732

Other finishes and dimensions are available upon request, only for large quantities.

311 < Floor grilles



Convactor grille

Material

- Made from aluminium sections: AlMgSi 0.5 (according to EN 12020-2)
- Finishing: anodised in satin colour (20 microns) or powder-coated in any RAL or Syntha PulvinR colour (40 microns)
- The frame is lined with a rubber gasket to guarantee a reduced noise level

Dimensions

- Bar spacing: 12.5 mm
- Grille section: 20 x 4 mm
- Maximum length:
 - Frame: 3.5 m
 - Grille: +/- 1 m
- Effective opening = length and width - 50 mm
- Bars arranged crosswise

Fixing

- Brackets ref. 231

Cross-sections

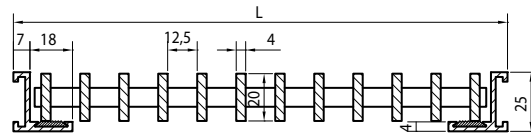

- 311/1: Floor grille or convactor cover with flangeless "L" frame

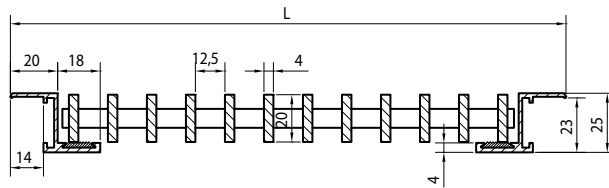

- 311/2: Floor grille or convactor cover with flanged "Z" frame

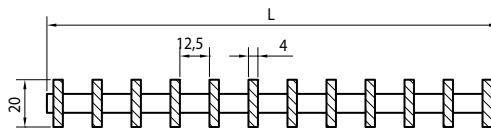

- 311/3: Frameless floor grille or convactor cover

Technical specifications

	311
Technical data	
Visual free area	76 %
Physical free area	76 %

Floor grille, heavy-duty series

Material

- Made from aluminium sections: AlMgSi 0.5 (according to EN 12020-2)
- Finishing: anodized in satin/bronze colour (20 micron) or powder-coated in any RAL or Syntha Pulvin colour (40 micron)
- The frame is lined with a rubber gasket to guarantee a reduced noise level

Dimensions

- Bar spacing: 12.5 mm
- Grille section: 20 x 8 mm
- Maximum length:
 - Frame: 3.5 m
 - Grille: +/- 1 m
- Effective opening = length and width - 50 mm
- Bars arranged crosswise

Fixing

- Brackets ref. 231

Typical applications

- Grilles for swimming pool drains, cellars, garages, car parks, abattoirs, etc.
- To cover underfloor wiring ducts in computer rooms.

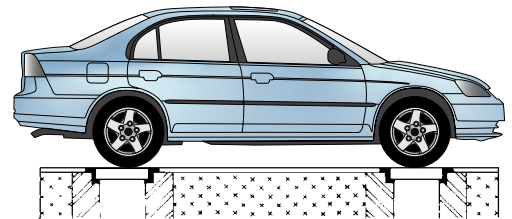

Cross-sections

- 371 / 1: Floor grille with flangeless "L" frame
- 371 / 3: Frameless floor grille

Technical specifications	
	371
Technical data	
Visual free area	61 %
Physical free area	61 %

392 < Linear bar grilles



Linear bar grille

Material

- Made from aluminium sections: AlMgSi 0.5 (according to EN 12020-2)
- Finishing: anodized in satin/bronze colour (20 micron) or powder-coated in any RAL or Syntha Pulvin colour (40 micron)

Dimensions

- Bar spacing: 10 mm
- Grille section: 16 x 3 mm
- Maximum length:
 - Frame: 3.5 m
 - Grille: +/- 1.6 m
- Maximum width:
 - Grille: 300 mm
- Effective opening = length and width - 50 mm
- Deflection: 15°
- Bars arranged lengthwise

Fixing

- No fasteners

Typical applications

- Radiator frame

Cross-sections

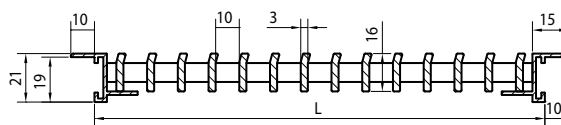

- 392/2: Linear bar grille with flanged "Z" frame

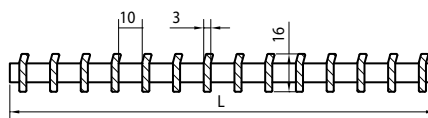

- 392/3: Frameless linear bar grille

Technical specifications

	392
Technical data	
Visual free area	76 %
Physical free area	76 %

Remark: Not designed to walk on!

Linear bar grille for self-assembly

Material

- Made from aluminium sections: AlMgSi 0.5 (according to EN 12020-2)
- Finishing: anodized in satin/bronze colour (20 micron) or powder-coated in any RAL or Syntha Pulvin colour (40 micron)

Dimensions

- Bar spacing: 9.5 mm
- Section length: 3 or 6 metres
- Clip length: 209 mm
- Bars arranged lengthwise

Fixing

- No fasteners

Number of clip sections/length

- 300 - 500 mm: 2 pieces
- 501 - 900 mm: 3 pieces
- 901 - 1300 mm: 4 pieces
- 1301 - 1700 mm: 5 pieces
- 1701 - 2100 mm: 6 pieces
- 2101 - 2600 mm: 7 pieces
- 2601 - 3000 mm: 8 pieces

Elements

- Simple clip assembly

Typical applications

- Counters, radiator frame

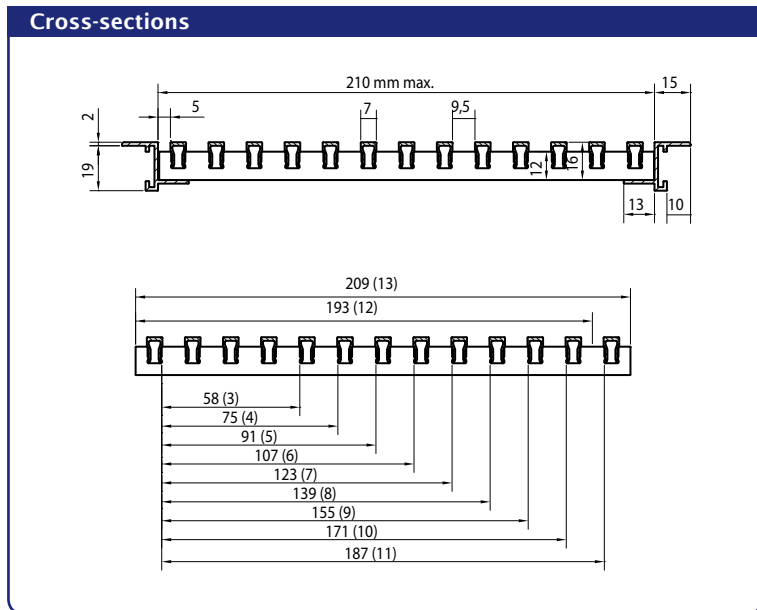
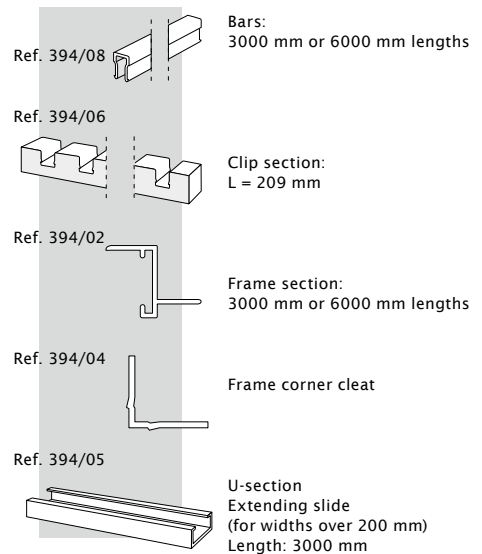

Technical specifications	
	394
Technical data	
Visual free area	59 %
Physical free area	59 %

Not designed to walk on!



461 < Door grilles



Door grille

Material

- Made from aluminium sections: AlMgSi 0.5 (according to EN 12020-2)
- Finishing: anodized in satin/bronze colour (20 micron) or powder-coated in any RAL or Syntha Pulvin colour (40 micron)
- Opaque grille with backframe and fixing screws

Dimensions

- Door thickness: 30 to 54 mm
- Maximum width (in one piece): 800 mm

Fixing

- Screws are included

Options

- Controllable version (type 463)
- Frame for 54 to 80 mm thickness on request

Cross-section

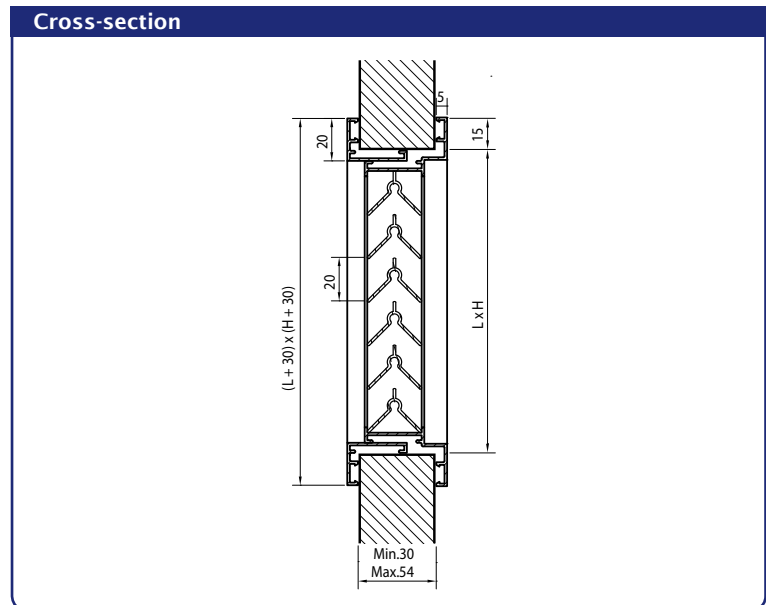

Stock models

Dimensions length x height (L) x (H)	Satin anodised	RAL 9010	RAL 8019	Airflow at 2 Pa in m ³ /h	Airflow at 20 Pa in m ³ /h	Visual free area	Physical free area
200 x 100 mm	•			13,6	43,0		
400 x 200 mm	•	•	•	72,4	228,9		
400 x 300 mm	•			117,6	371,9	93%	39%
500 x 300 mm	•			147,0	464,9		
600 x 400 mm	•			244,2	772,2		
425 x 76 mm	•	•	•	19,2	60,7		

Acoustic door grille for residential sector

Material

- Made from aluminium sections: AlMgSi 0.5 (according to EN 12020-2)
- Sound absorbing material: synthetic foam
- End caps: in Luran S ASA polymer (colourfast, weatherproof and UV-resistant)
- End caps: available in grey, black or white

Dimensions

- Length: 425 mm
- Height: 48 mm
- Door thickness: 37 to 43 mm

Available models

- The Silendo R is available in a standard 425 x 48 mm size in the following standard colours: RAL 9010 (with matching white end caps), RAL 8019 (black end caps) and natural colour (grey end caps).
- Other lengths and colours available on request.

Typical applications

- offices, commercial buildings, toilet doors

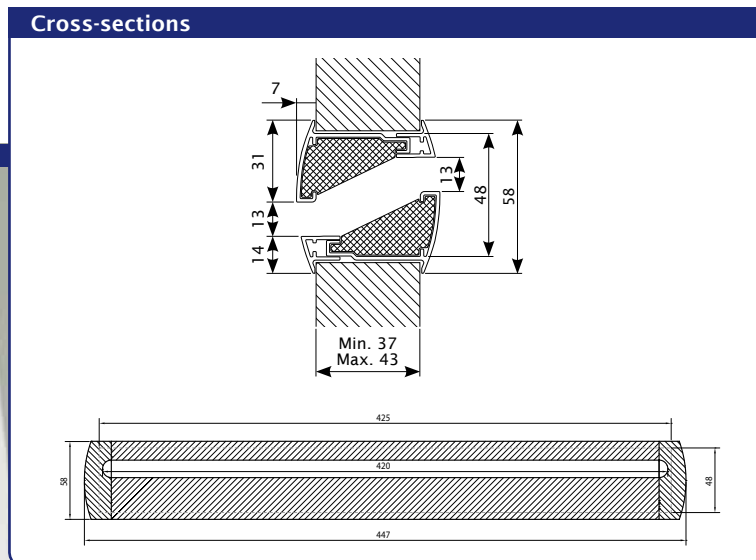

Technical specifications	
	Silendo®
Airflow	(EN 13141-1)
Q at 1 Pa	17,7 m3/h
Q at 2 Pa	25,1 m3/h
Q at 10 Pa	56,1 m3/h
Q at 20 Pa	79,4 m3/h
Comfort	(EN ISO 140-10, EN ISO 717-1)
Sound reduction in open position $R_w (C; C_{tr})$	32 (0;-2) dB
Technical data	
Visual free area	27%
Physical free area	27%

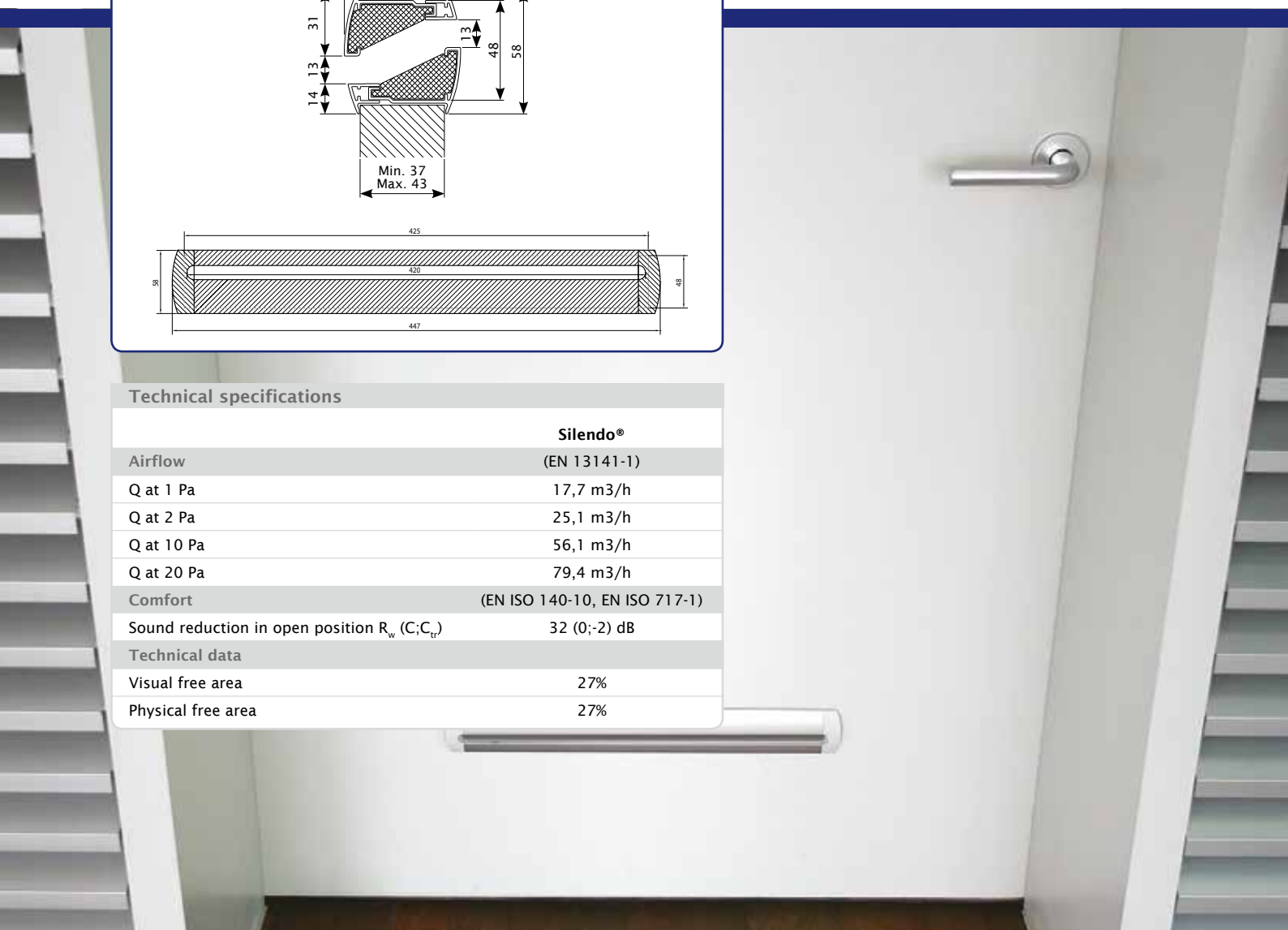

Invisido® 469 < Door grilles



Acoustic door grille for residential sector

Material

- Sound absorbing material: synthetic foam
- End caps: in Luran S ASA polymer (colourfast, weatherproof and UV-resistant)
- End caps: available in grey, black, cream or white; other colors available on demand

Dimensions

- maximum length: 2000 mm
- Standard length: 725 mm (type 730), 825 mm (type 830), 925 mm (type 930)
- Door thickness: 35 mm

Fixing

- Screws included

Typical applications

- No look-through
- Residential, aesthetical
- In combination with Renson system C+ and System C+^{EVO}

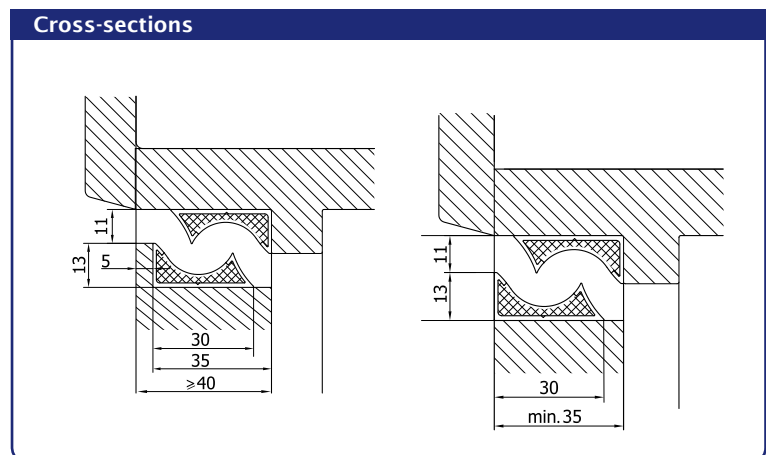

Technical specifications

Invisido® type 469	
Airflow (EN 13141-1)	
Q at 1 Pa	17,6 m³/h (4,9 dm³/s)
Q at 2 Pa	25,3 m³/h
Q at 10 Pa	58,8 m³/h
Q at 20 Pa	84,7 m³/h
Comfort (EN ISO 140-10, EN ISO 717-1)	
Sound reduction $D_{n,e,w}$ (C;C _{tr})	28 (-1;0) dB

Acoustic door grille

Material

- Made from aluminium sections: AlMgSi 0.5 (according to EN 12020-2)
- Finishing: anodized in satin/bronze colour (20 micron) or powder-coated in any RAL or Syntha Pulvin colour (40 micron)
- Sound absorbing material: synthetic foam

Dimensions

- Minimum dimensions: 200 x 193 mm H
- Maximum dimensions: 800 x 788 mm H
- Fitting dimensions: 7 mm more than the grille dimensions.
- Height in 85 mm steps (blade pitch)
- Door thickness: from 37.5 to 92 mm

Available models

- The 468 AK/2 is available in RAL 9910 in the following standard sizes: 292 x 193 mm, 382 x 278 mm, 432 x 363 mm and 452 x 448 mm.
- Other sizes and colours available on request.

Typical applications

- Schools, dressing rooms, garagedoors, central heating system rooms, hospitals

Remark: for internal use only!

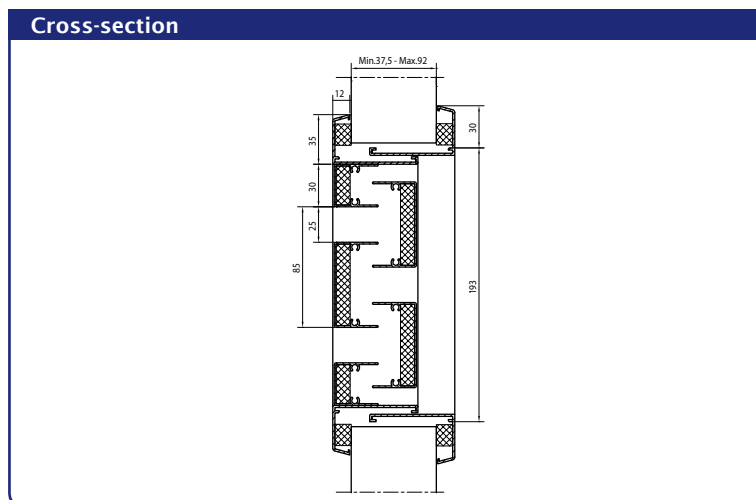

Technical specifications		
468 AK/2		
Airflow	(EN 13030)	(EN 13030)
K-factor (supply)	86,85	
K-factor (discharge)	89,35	
C _e coefficient	0,107	
C _d coefficient	0,106	
Q at 2 Pa - grille 292 x 193 mm	25 m ³ /h	30 (-1;-2) dB
Q at 2 Pa - grille 382 x 278 mm	50 m ³ /h	28 (-1;-2) dB
Q at 2 Pa - grille 432 x 363 mm	75 m ³ /h	26 (-1;-2) dB
Q at 2 Pa - grille 452 x 448 mm	100 m ³ /h	25 (-1;-2) dB
Comfort (EN ISO 140-10, EN ISO 717-1)		
Sound reduction in open position R _w (C;C _{tr})	8 (-1;-2) dB	
Technical data		
Visual free area	29 %	
Physical free area	29 %	
Ip class (louvre with mesh)	IP2XD	

Incendo® 464 < Fire-resistant louvres



Fire-resistant louvre with angled blades, fire-resistance 60'

Material

- Blades filled with intumescent material
- Outer frame in Polystyrene
- Available in RAL 7024 (anthracite grey), RAL 9016 (traffic white) en RAL 9022 (pearl light grey)

Dimensions

- Maximum dimension: 800 x 400 mm
- Minimum dimensions: 100 x 100 mm
- 464/1: with frame, 464/2: with frame and adjustable counterframe

Fixing

- With sealant and adhesive neoprene mastic

Typical applications

- Aesthetic finish, no visible vertical posts
- Tested according to EN1634-1, EN1364-1 and EN1364-2
- Fire resistance EI 60 (Integrity and thermal insulation for 1 hour) according to EN13501-2
- Suitable for installation in a wooden door panel, flexible wall, massive wall, floor or ceiling.
- No visual see through
- Avoid contact with water, for indoor use only

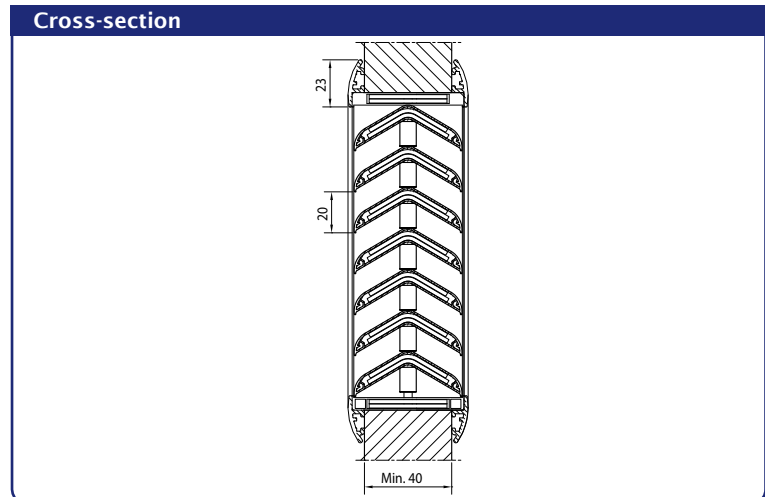
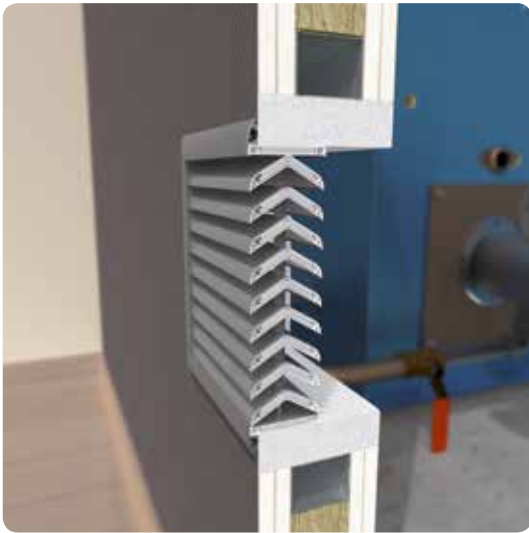

Technical specifications	
	Incendo® 464
Airflow	(EN 13030)
K-factor (supply)	10,27
K-factor (discharge)	10,27
C _e coefficient	0,312
C _d coefficient	0,312
Technical specifications	
Visual free area	61 %
Physical free area	51 %
Ip class	IP2XD
Fire resistance	(EN 13501-2)
Massive (concrete) wall (100 mm)	EI 60/ EW 90 (ve i<->o)
Massive (concrete) floor (100 mm)	EI 60 (ho i<->o)
Flexible wall (metal stud gypsum plasterboard 100 mm)	EI 60 (ve i<->o)
(wooden) doorpanel (50 mm)	EI 60 / EW 60 (ve i<->o)
(wooden) doorpanel (40 mm)	EI 30 / EW 30 (ve i<->o)

Fire-resistant louvre with angled blades, fire-resistance 60'

Material

- Blades filled with intumescent materials (PALUSOL)
- Protection by grey-coloured synthetic sheath
- Outer frame in satin anodised aluminium (20 microns)
- Other framecolors on request.

Dimensions

- Maximum dimensions: 600 x 300 mm
- Special dimensions on request

Purpose

- Ventilation between two adjacent rooms.
- In case of fire, cuts off the airflow and fulfils a firebreak function.

Applications

- Fire-resistant constructions
- Fire-resistant conduit
- Fire doors
- For indoor use only

Function

- At a temperature of 120°C, the blades swell to close the vent.
- Forms a static fire valve for 60 minutes.

Technical specifications

- Fire resistance: Rf 1 hour
- Testreport on request (Belgian BBRI test)
- Visual free area: 74%

Fixing

- Secure the louvre in the opening
- Fill the gap between the louvre and the door/wall with fire-resistant mortar.

Typical applications

- Fire door apartments



Stock models

Dimensions length x high (L) x (H)	465/1 (with frame)	465/2 (with frame and backframe)
200 x 200 mm	•	
300 x 300 mm	•	
400 x 200 mm	•	•
500 x 200 mm	•	

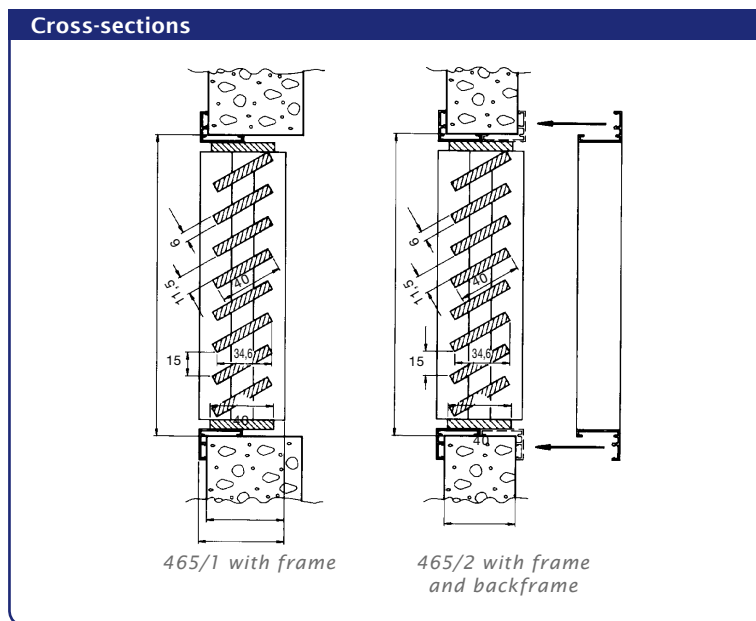

466 < Fire-resistant louvres



Fire-resistant louvre with horizontal blades

Material

- Blades filled with intumescent materials (PALUSOL)
- Protection by grey-coloured synthetic sheath
- Outer frame in satin anodised aluminium (20 microns)
- Other framecolors on request.

Dimensions

- Maximum dimensions: 600 x 400 mm
- Dimensions on request

Purpose

- At normal temperature, guarantees ventilation between two adjacent rooms.
- In case of fire, cuts off the airflow and fulfils a firebreak function.

Applications

- Fire-resistant constructions
- Fire-resistant conduit
- Fire doors
- For indoor use only

Function

- At a temperature of 120°C, the blades swell to close the vent.
- Forms a static fire valve for 60 minutes.

Technical specifications

- Fire resistance: Rf 1 hour
- Testreport on request (Belgian BBRI test)
- Visual free area: 70%

Fixing

- Secure the louvre in the opening
- Fill the gap between the louvre and the door/wall with fire-resistant mortar.

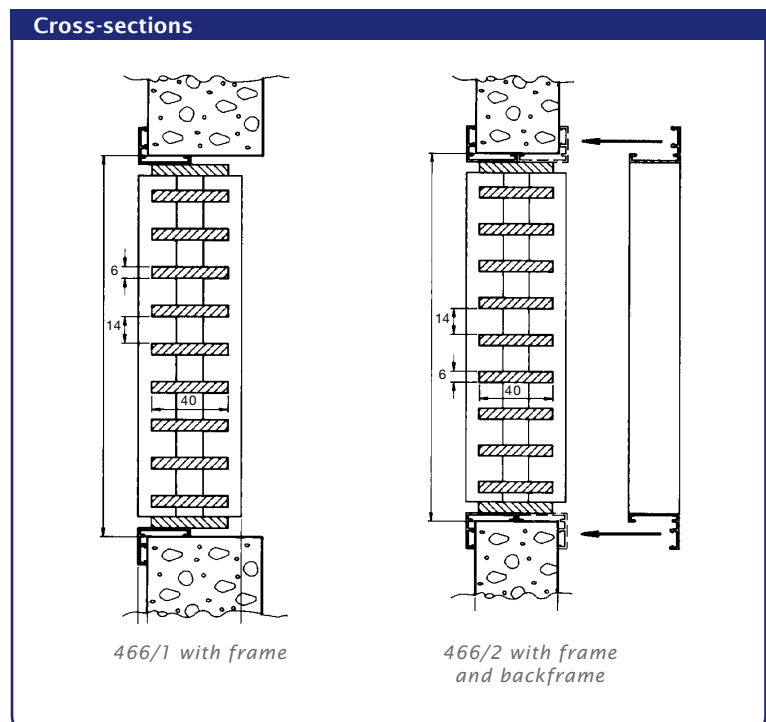

Round louvres



411R < Built-in wall louvres



Round wall louvre (with frame)

Material

- Made from aluminium sections: AlMgSi 0.5 (according to EN 12020-2)
- Stainless steel 304 insect screen (2.3 x 2.3 mm) or mesh (6 x 6 mm) on request
- Finishing: anodized in satin/bronze colour (20 micron) or powder-coated in any RAL or Syntha Pulvin colour (40 micron)
- Frame assembled by a single weld

Dimensions

- Blade pitch: 33,3 mm
- Depth to fit: 28.2 mm
- Flange size: 23 mm
- Minimum diameter: 300 mm
- Maximum diameter:
 - 1400 mm if anodised in satin colour
 - 1500 mm if powder-coated in RAL or Syntha Pulvin colour
 - over 1500 mm: in two parts

Fixing

- Brackets pre-fitted to the frame

Typical applications

- Every application without specific needs

Cross-sections

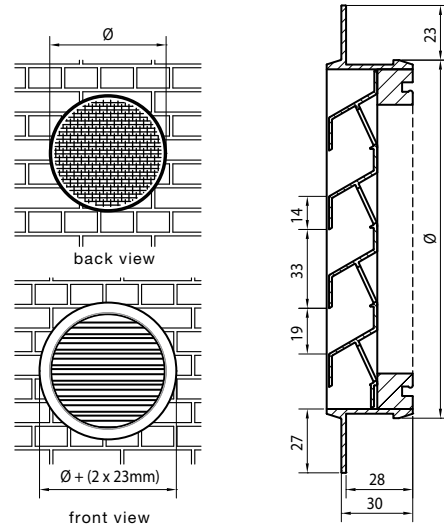

Technical specifications

411R	
Airflow	(EN 13030)
K-factor (supply)	23,56
K-factor (discharge)	25,51
C _e coefficient	0,206
C _d coefficient	0,198
Technical data	
Visual free area	59 %
Physical free area	40,5 %
IP class (louvre with mesh; electrical installation at least 100mm from louvre)	IP2XD

Round wall louvre with chevron section blades

Material

- Made from aluminium sections: AlMgSi 0.5 (according to EN 12020-2)
- Stainless steel 304 mesh (6 x 6 mm) or insect screen (2.3 x 2.3 mm) on request
- Finishing: anodized in satin/bronze colour (20 micron) or powder-coated in any RAL or Syntha Pulvin colour (40 micron)
- Frame assembled by a single weld

Dimensions

- Blade pitch: 20 mm chevron
- Depth to fit: 34 mm
- Flange size: 23 mm
- Minimum diameter: 300 mm
- Maximum diameter:
 - 1400 mm if anodised in satin colour
 - 1500 mm if powder-coated in RAL or Syntha Pulvin colour
 - over 1500 mm: in two parts

Fixing

- Brackets pre-fit to the frame

Typical applications

- High-voltage stations
- IT rooms

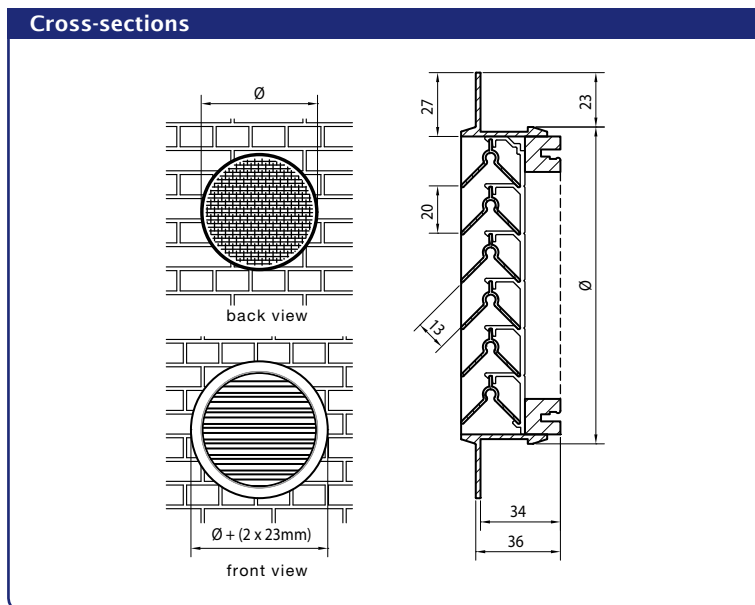

Technical specifications	
	412R
Airflow	(EN 13030)
K-factor (supply)	33,80
K-factor (discharge)	33,80
C _e coefficient	0,172
C _d coefficient	0,172
Technical data	
Visual free area	93 %
Physical free area	39 %
IP class	IP2XD

421R < Built-in wall louvres



Round wall louvre, heavy-duty series

Material

- Made from aluminium sections: AlMgSi 0.5 (according to EN 12020-2)
- Finishing: anodised in satin colour (20 microns) or powder-coated in any RAL or Syntha PulvinR colour (40 microns)
- Stainless steel 304 insect screen (2.3 x 2.3 mm) or mesh (6 x 6 mm) on request
- Frame assembled by a single weld

Dimensions

- Blade pitch: 50 mm
- Depth to fit: 57 mm
- Flange size: 22 mm
- Minimum diameter: 400 mm
- Maximum diameter:
 - 1400 mm if anodised in satin colour
 - 1500 mm if powder-coated in RAL or Syntha Pulvin colour
 - over 1500 mm: in two parts

Fixing

- Brackets pre-fitted to the frame

Typical applications

- Applications where aesthetics and strength are key parameters.

Cross-section

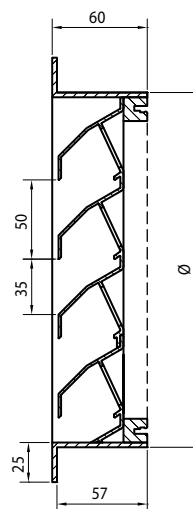

Technical specifications

	421R
Airflow	(EN 13030)
K-factor (supply)	12,57
K-factor (discharge)	8,91
C _e coefficient	0,282
C _d coefficient	0,335
Technical data	
Visual free area	70 %
Physical free area	47 %
IP class (louvre with mesh; electrical installation at least 100mm from louvre)	IP2XD

Round louvre without frame

Material

- Made from aluminium sections: AlMgSi 0.5 (according to EN 12020-2)
- Stainless steel 304 insect screen (2.3 x 2.3 mm) or mesh (6 x 6 mm) on request
- Finishing: anodized in satin/bronze colour (20 micron) or powder-coated in any RAL or Syntha Pulvin colour (40 micron)

Dimensions

- Blade pitch: 33,3 mm
- Depth to fit: 40 mm
- Minimum diameter: 300 mm
- Maximum diameter:
 - 1400 mm if anodised in satin colour
 - 1500 mm if powder-coated in RAL or Syntha PulvinR colour
 - over 1500 mm: in two parts

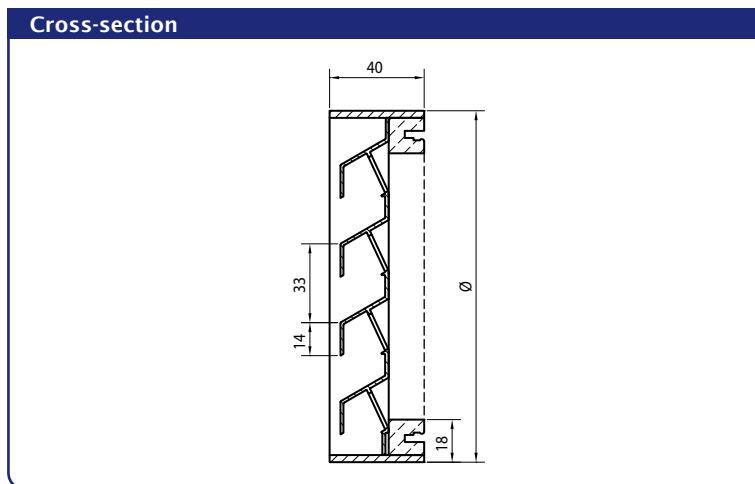

Technical specifications	
	431R
Airflow	(EN 13030)
K-factor (supply)	23,56
K-factor (discharge)	25,51
C _e coefficient	0,206
C _d coefficient	0,198
Technical data	
Visual free area	58 %
Physical free area	45 %
IP class (louvre with mesh; electrical installation at least 100mm from louvre)	IP2XD

414R < Glazed-in louvres



Round glazed-in louvre

Material

- Made from aluminium sections: AlMgSi 0.5 (according to EN 12020-2)
- Stainless steel 304 insect screen (2.3 x 2.3 mm) or mesh (6 x 6 mm) on request
- Finishing: anodised in satin/bronze colour (20 micron) or powder-coated in any RAL or Syntha Pulvin colour (40 micron)

Dimensions

- Blade pitch: 33,3 mm
- Frame thickness: 24 mm
- Minimum diameter: 340 mm
- Maximum diameter:
 - 1400 mm if anodised in satin colour
 - 1500 mm if powder-coated in RAL or Syntha PulvinR colour
 - over 1500 mm: in two parts

Fixing

- Suitable for 24, 28, 32 mm glazing sections. Other thicknesses on request.

Cross-section

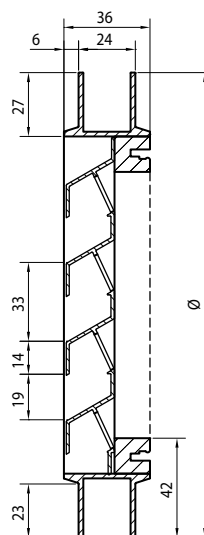

Technical specifications

	414R
Airflow	(EN 13030)
K-factor (supply)	23,56
K-factor (discharge)	25,51
C _e coefficient	0,206
C _d coefficient	0,198
Technical data	
Visual free area	59 %
Physical free area	40,5 %
IP class (louvre with mesh; electrical installation at least 100mm from louvre)	IP2XD

Round louvre with chevron section blade

Material

- Made from aluminium sections: AlMgSi 0.5 (according to EN 12020-2)
- Stainless steel 304 mesh (6 x 6 mm) or insect screen (2.3 x 2.3 mm) on request
- Finishing: anodized in satin/bronze colour (20 micron) or powder-coated in any RAL or Syntha Pulvin colour (40 micron)
- Frame assembled by a single weld

Dimensions

- Blade pitch: 20 mm
- Frame thickness: 24 mm
- Minimum diameter: 340 mm
- Maximum diameter:
 - 1400 mm if anodised in satin colour
 - 1500 mm if powder-coated in RAL or Syntha Pulvin colour
 - over 1500 mm: in two parts

Fixing

- Suitable for 24, 28, 32 mm glazing sections. Other thicknesses on request.

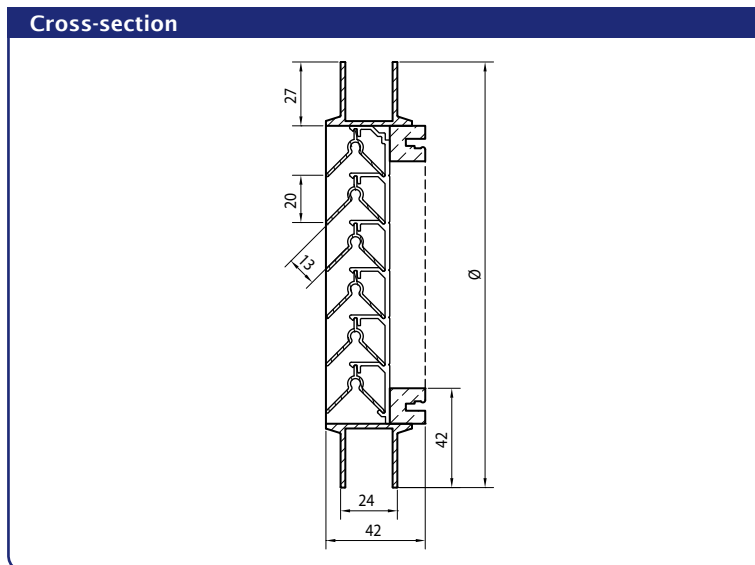
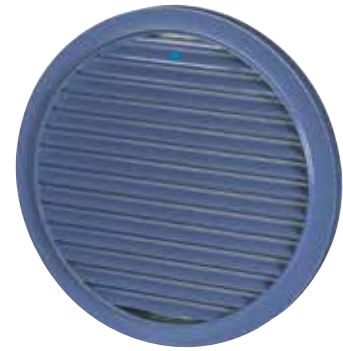

Technical specifications	
	415R
Airflow	(EN 13030)
K-factor (supply)	33,80
K-factor (discharge)	33,80
C _e coefficient	0,172
C _d coefficient	0,172
Technical data	
Visual free area	93 %
Physical free area	39 %
IP class	IP2XD

References







Cherfan Draperies S.A.R.L., Jal El Dib Main Roan, P.O.Box 60-367 Beirut Lebanon

T + 961 4 710061 F + 961 4 719061 E info@creashade.com W www.creashade.com

Canada Branch: Creashade Canada Inc., 505 Industrial, Road Unit B2, Ottawa, Ontario K1G OZ1

T + 1 613 627 3959 M + 1 613 794 0097