



**CREASHADE**  
SUN SHADING SOLUTIONS



## Linius<sup>®</sup>

Continuous louvre system

## Contents

<b>Introduction</b>			
Table of contents	2	LD.0995	61
RENSON® company profile	3	LD.1250	62
References	4	<b>Sunclips® support structure</b>	
Purpose of the CLS	7	SD.014 / SD.054 / SD.100	63
Overview	8	<b>System depth</b>	64
<b>Blade types</b>		<b>Fixing elements</b>	
L.033	12	Fixing brackets	
L.033 Variations	14	LZ.4202 and LZ.4211	65
L.050	18	U-shape mounting bracket LZ.4210	66
L.050HF	20	Angle bracket	
L.050W / L.050WS	22	Type LZ.4203 and LZ.4209	66
L.050CL	24	<b>Accessories</b>	
L.060HF	25	A. Mesh	67
L.066	26	B. Sills	69
L.066CL	28	C. Aluminium frames	70
L.066IM1	29	D. Doors	71
L.066V	30	<b>Specialities</b>	
L.075	32	A. Linius®-cassette system	73
L.095	34	B. Curved blades	74
L.120	36	C. Stand alone support structures	75
L.065AL / L.065 GL / L.065STS	38	D. Acoustic applications	75
L.060AC	40	E. Mitred corners	76
L.150ACS / L.170ACS /		F. Special shapes	77
L.150ACL / L.170ACL	42	G. Block blades L.033 and L.050	77
L.150DAC / L.170DAC	44	H. Turrets	78
L.066P	46	I. Louvre grilles	78
Aesthetic blades for cladding		J. Aesthetic façade cladding with	
sunprotection	48	Sunclips® and Icarus® blades	79
Sunclips® Evo	49	<b>Storage and maintenance</b>	
<b>Selection criteria</b>	50	Care of equipment and materials	79
<b>Water penetration test</b>		General instructions	80
<b>(or HEVAC tests) - principle</b>	52	Summary of RENSON® Linius®	
<b>Overview table</b>	54	continuous louvre system specifications	82
<b>Supporting structures</b>	56	<b>References</b>	83
LD.0065	57		
LD.0195	58		
LD.0440	59		
LD.0460	60		



## RENSON® company profile

### 6 good reasons to have RENSON® as a partner.

1. Customer satisfaction by personal contact, professional advice, excellent service and reliable, high-performance products are the main aims of our company.
2. RENSON® is a reputable and established multinational company with international expertise and experience thanks to the efforts of our local specialists. They are present in all regions of the world. RENSON has assisted with projects across the whole world, from Moscow to Tahiti and from Monaco to Shanghai.
3. A complete service from start to finish, effective support and advice during the design phase, site meetings and installation.
4. The production process is fully vertically integrated enabling manufacturing to the strictest of standards. Investments in injection moulding machinery, anodising facilities and a fully automatic powder coating installation ensure efficiency and accuracy.
5. Continuous research and development translates customer needs into unique solutions and innovative products.
6. RENSON® specialises in all aspects of ventilation and solar shading to achieve the current goals of the Healthy Building Concept®.



## Worldwide reference list

### BELGIUM

Madou Tower - Brussels  
 Hogeschool GroepT - Leuven  
 Airport - Zaventem  
 Smithkline Beecham plant - Brussels  
 Alcatel building - Antwerp  
 Private house /office - Menen  
 Private residence - Bruges  
 Brandweerkazerne - Oudenaarde  
 Hospitalier Regional du Val de Sambre - Auvelais  
 Secure Link - Wommelgem  
 Atlantis - Sint-Agatha-Berchem

### FRANCE

Futuroscope - Poitiers  
 Euralille - Rijsel  
 Paris-Expo - Parijs  
 UVE - Rouen  
 Gemey Maybelline - Orléans  
 (Arch : Alain Bailly - Lionel Colson, Paris)  
 Siège SNCF - Mouchotte, Paris  
 CHU - Perpignan  
 Ifremer - Sète  
 Thomson - Rousset  
 Inria - Rennes  
 Institut Regional de Readapton - Nancy  
 I.R.R. Louis Pierquin - Nancy  
 Aérogare - Brest  
 Hospital Centre - Cannes  
 Palazzo delle esposizioni - Monaco  
 La goutte d'eau - Bègles  
 Centre hospitalier - Libourne

### GERMANY

AIRBUS - Hamburg  
 Luchthaven - Frankfurt  
 Messehalle - Frankfurt  
 VW Design - Potsdam  
 Audi - Neckarsulm  
 Government quarter - Erfurt  
 Technology Centre - Gelsenkirchen  
 Peek & Cloppenburg - Cologne  
 Parking - Rostock  
 Technology Centre - Heidelberg  
 Wilmersdorf Arcades - Berlin  
 LSG Sky Chefs - Frankfurt  
 Elbe Shopping Centre - Hamburg  
 Erlangen Arcades - Erlangen  
 Frauenhof Institute - Magdeburg  
 Labour Agency - Berlin-Central  
 O<sub>2</sub> World Arena - Berlin

EEZ Hamburg - Hamburg  
 Solon AG - Berlin  
 Bürohaus Scharnhausen - Ostfildern  
 America Center - Hamburg  
 Glückaufhaus - Essen  
 Messehalle - Frankfurt  
 Tempelhofer Hafen - Berlin  
 Kaufzentrum - Marl  
 Debeka Versicherung - Koblenz  
 Spree Dreieck - Berlin

### ISRAEL

Telephone company - Naharia

### HUNGARY

Vodafone - Budapest  
 NBC-Building - Budapest  
 Millenium Towers - Budapest

### ITALY

University - Bologna  
 Parkhaus Köstlan - Brixen/Bressanone  
 Südtirol

### POLAND

Riviera - Warszawa  
 Reform Plaza - Warszawa  
 Metro - Warszawa  
 Hotel Mercure - Poznan  
 Galeria Kazimierz - Kraków  
 Marino Shopping Center - Wroclaw  
 Promag SA - Poznan

### NEDERLAND

Bouwhuis - Zoetermeer  
 HST station - Barendrecht  
 Mosae Forum - Maastricht  
 High Tech Centre Philips - Eindhoven  
 Haagse Poort - The Hague  
 Prinsenhof - The Hague  
 Showbizzcity - Aalsmeer  
 BAM Krasnapolsky - Amsterdam  
 Alexandrium - Amsterdam  
 Scheepvaart en transportcollege - Rotterdam  
 Marine museum - Rotterdam  
 KPN Callcenter - Amersfoort  
 Sony Music - Delft  
 Philips high tech campus - Eindhoven  
 Amaliahof - Wissenkerke  
 Pier K - Nieuw-Vennep  
 Brandweerkazerne - Pijnacker

Sportcomplex Pitchpegloor - Tilburg  
 Electrabel - Zwolle  
 ROC Technovium - Nijmegen  
 Windesheim - Zwolle  
 Port City - Rotterdam  
 De Ronde Venen - Mijdrecht

### TURKEY

Pamuk Bank - Istanbul

### UNITED KINGDOM

More - London  
 Fetter Lane - London  
 Concert Hall - Perth  
 Royal Opera House - London  
 Carlton Gardens - London  
 Odeon - Glasgow  
 Breahead Park - Glasgow  
 Sunderland aquatics centre  
 Clarence Dock - Leeds  
 BBC - London  
 British Library - Boston Spa Whetherby  
 Wembley Stadium - London, Wembley  
 Sweeny Crescent, Residential - London  
 Westminster College - London

### SWITZERLAND

World Trade Center - Lugano  
 Flughafen Zürich - Zürich

### LUXEMBOURG

Licée technique du Centre - Dommeldange

### AUSTRIA

Uniqua Tower - Wien  
 Hypo Tirol - Innsbruck  
 Mutter-Kind-Zentrum - Linz  
 Sparkasse Linz - Linz  
 Logistikhalle Privatbrauerei - Zwettl

### PORTUGAL

Frente Mar da Ribeira de Boaventura - Madeira

### CZECH REPUBLIC

Prosek Metrostation - Prague

### SPAIN

Mandarin Oriental - Barcelona



Ref. Sunderland Aquatics Centre, Sunderland (UK), Arch. Red Box Architecture



Ref. Inria, Rennes (F), L.075S



Ref. Fraunhoferinstitut VDTC, Magdeburg (D), L.050 and L.033



Ref. Private House/office – Mennan (B), Arch. Philippe GUILBERT



Ref. Les Iris – Toulouse (F), O.P.A.C. – Arch. Tassera – Toulouse. Company : SMAC ACIEROID

# References < Introduction



Ref. VM Skoda garage, Gent (B), L.033



Ref. LSG Sky Chefs, Frankfurt (D), L.050.09



Ref. Privéwoning, Bruges (B), L.033



Ref. Concordia, Waregem (B), L.066



Ref. Clarence Dock, Leeds (UK), Arch. CareyJones, L050 - 60% FA



Ref. Frente Mar da Ribeira de Boaventura, Madeira (PT)



1



2

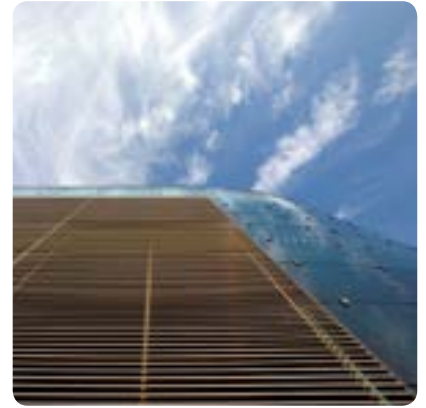

3



4



5



6

#### 1. Screening

An application ideal for concealing unsightly equipment from view.

#### 2. Ventilation

An assembly allowing the air flow in and out of a building whilst restricting the entry of rain. Here the CLS offers by far the best aesthetic solution.

#### 3. Screening against the weather

The continuous louvres system protects your installation from wind, rain and vermin.

#### 4. Acoustics

Fitted with acoustic blades, the CLS is ideal for the screening of noisy installations. The structure of the louvres system together with the noise damping qualities ensure that noise is strongly damped, while keeping good ventilation.

#### 5. Aesthetic cladding

Applications in which the blade profile design is preferred to other applications.

#### 6. Interior

Interior cladding, possibly incorporating back lighting.

# Overview

The continuous louvre system consists of a support structure to which blades are fitted.

The support structure carries the complete louvre assembly and is formed by vertically or horizontal placed mullions fixed by brackets at set distances. Depending on the structure, RENSON offers different mullion types. Blade supports are permanently fixed to the mullions allowing the blades to be clip-locked onto their supports. The method of construction is simple and well tested. Mitred corners, doors, vermin, bird or insect screens can all be incorporated.

Depending on the application, different constructions are possible.

## Blade types

### Extruded aluminium - standard blades:

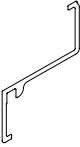
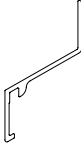
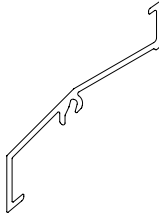
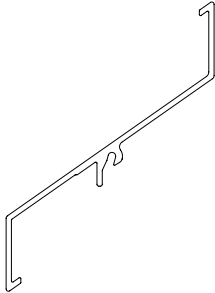
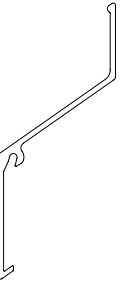
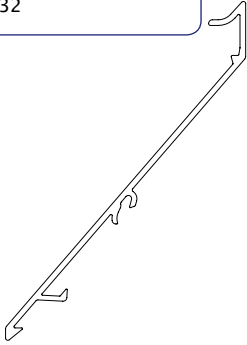
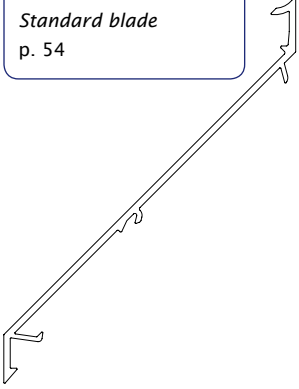
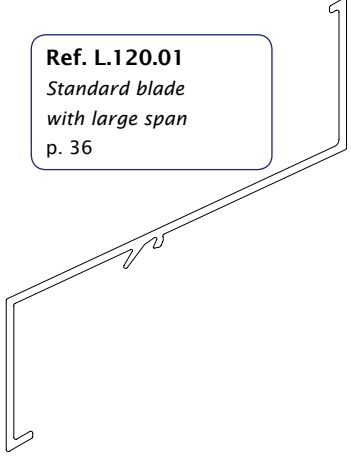
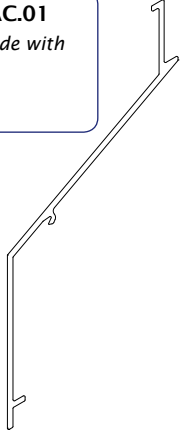
<b>Ref. L.033.01</b> <i>Standard blade</i> p. 12	<b>Ref. L.033HF</b> <i>Blade with large free area</i> p. 16	<b>Ref. L.050.00</b> <i>Standard blade</i> p. 18	<b>Ref. L.066.01</b> <i>Standard blade</i> p. 26	<b>Ref. L.066.06</b> <i>Blade with extended nose</i> p. 26
				
<b>Ref. L.075.01</b> <i>Standard blade</i> p. 32	<b>Ref. L.095.01</b> <i>Standard blade</i> p. 54	<b>Ref. L.120.01</b> <i>Standard blade with large span</i> p. 36	<b>Ref. L.150.DAC.01</b> <i>Combinable blade with acoustic system</i> p. 44	
				

### Extruded aluminium - blades with large free area:

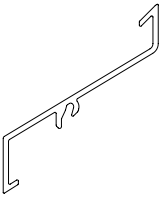
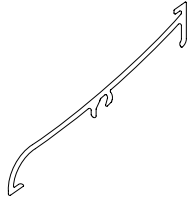
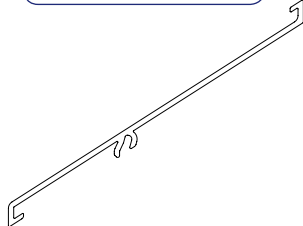
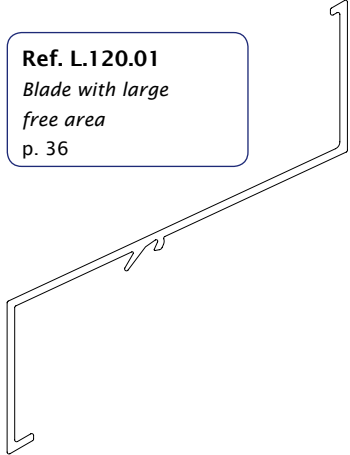
<b>Ref. L.050HF</b> <i>Blade with large free area</i> p. 20	<b>Ref. L.050WS</b> <i>Combinable blade with high performance system</i> p. 22	<b>Ref. L.060HF</b> <i>Blade with large free area</i> p. 25	<b>Ref. L.120.01</b> <i>Blade with large free area</i> p. 36
			

**Extruded aluminium - blades for restricted access and visual screening:**

**Ref. L.033.08**  
*Labyrinthe blade*  
p. 14

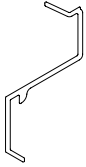

**Ref. L.033V**  
*V-blade*  
p. 14

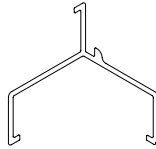

**Ref. L.066V**  
*V-blade*  
p. 30

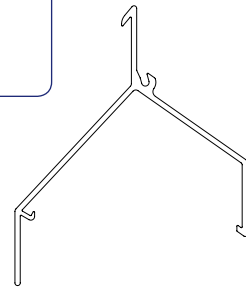

**Extruded aluminium - acoustic blades:**

**Ref. L.060AC**  
*Acoustic blade*  
p. 40

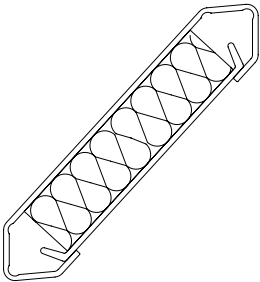

**Ref. L.150ACS.01**  
*Acoustic blade*  
p. 42

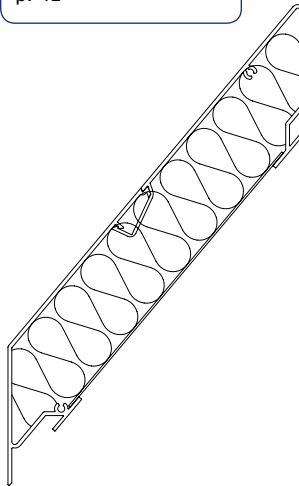

**Ref. L.150ACL.01**  
*Acoustic blade*  
p. 42

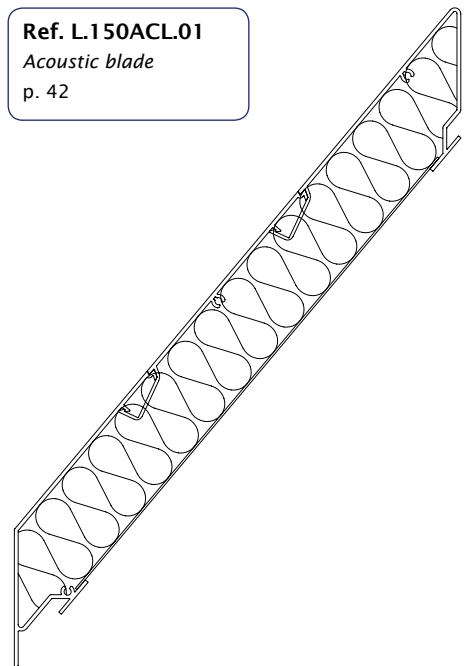

**Rolled aluminium - rolled sheet blades:**

**Ref. L.065AL & L.065AL.02**  
*Aluminium*  
p. 38

**Ref. L.065GL**  
*Galvanised steel*  
p. 38

**Ref. L.065StS**  
*Stainless steel*  
p. 38

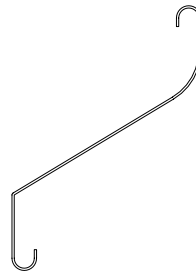
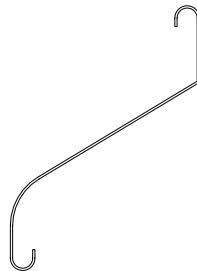

# Overview

## Extruded aluminium - aesthetic blades for cladding/sunprotection

**Ref. L.050.21**  
*Loggia® blade*  
p. 48

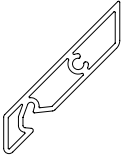

**Ref. L.066P**  
*Rectangular blade*  
p. 46



**Ref. L.066.21**  
*Loggia® blade*  
p. 48

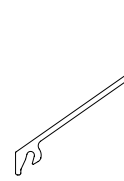

**Ref. SE.096**  
*Aluminium*  
p. 49

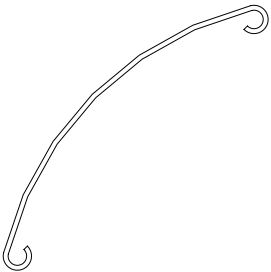

**Ref. SE.130**  
*Aluminium*  
p. 49

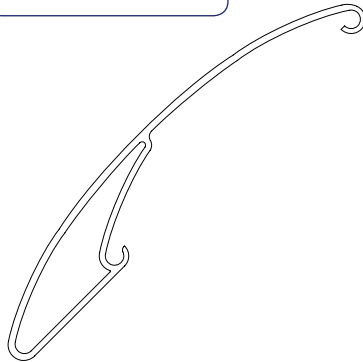

**Ref. SE.176**  
*Aluminium*  
p. 49

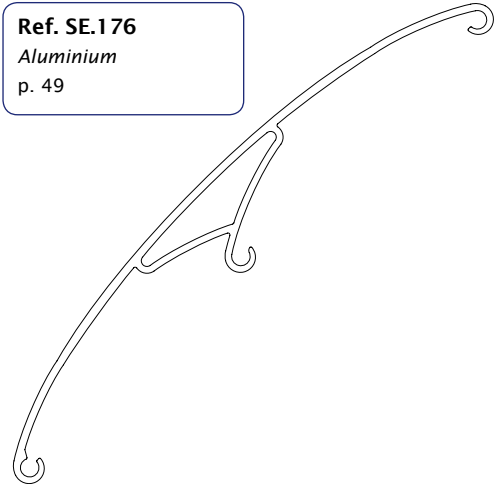

## Extruded aluminium - closed blades

**Ref. L.033CL**  
*Closed blade*  
p. 16

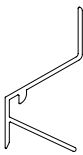

**Ref. L.050CL**  
*Closed blade*  
p. 24

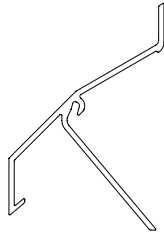

**Ref. L.066CL**  
*Closed blade*  
p. 28

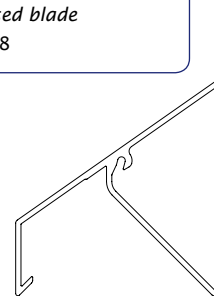

## Extruded aluminium - project profiles (\*)

**Ref. L.050.25**  
*Blade with extended nose*  
p. 20

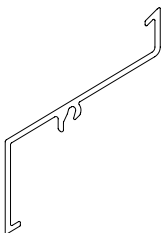

**Ref. L.066S**  
*Blade soft line*  
p. 26

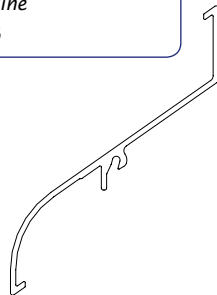

**Ref. L.075S**  
*Blade soft line*  
p. 32

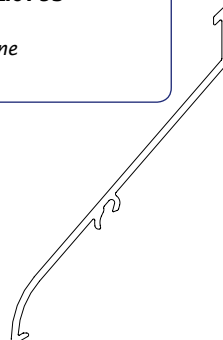

**Ref. L.095S**  
*Blade soft line*  
p. 34

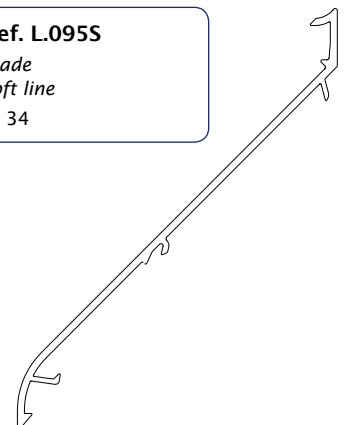

(\*) = Project profiles not in stock

# Overview

## Extruded aluminium – with integrated insect mesh

**Ref. L.033IM1**

*Blade with integrated insect mesh*  
p. 15

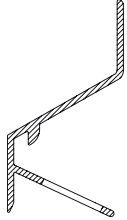

**Ref. L.066.IM1**

*Blade with integrated insect mesh*  
p. 29

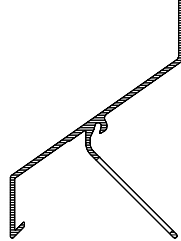

## Water resistant blade

**Ref. Extreme L.050W**

*High performance blade*  
p. 22

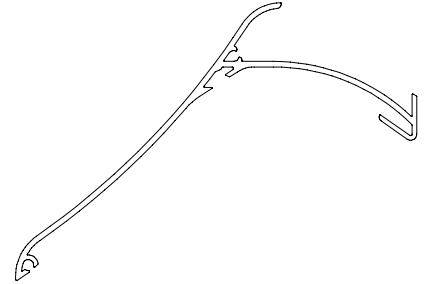

## Supporting structure Linius®

**Ref. LD.0065**

*Continuous support*  
p. 57



**Ref. LD.0440**

*For constructions and sideways fixation*  
p. 59

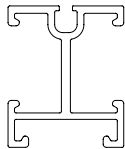

**Ref. LD.0460**

*Medium vertical span*  
p. 60

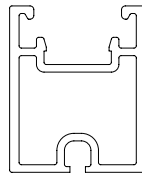

**Ref. LD.0995**

*Large vertical span*  
p. 61

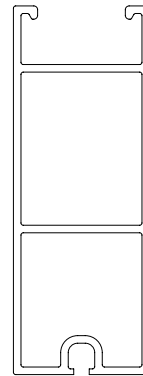

**Ref. LD.1250**

*For extra large unsupported spans*  
p. 62

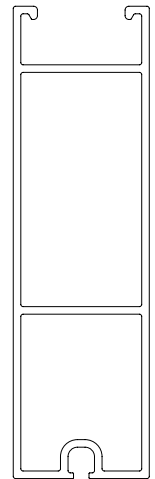

**Ref. LD.0195**

*Limited vertical span*  
p. 58

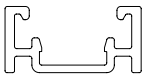

## Supporting structure Sunclips®

**Ref. LD.0108**

*Adapter profile*  
p. 63

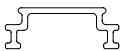

**Ref. SD.014**

*Continuous support*  
p. 63

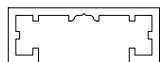

**Ref. SD.054**

*Medium vertical span*  
p. 63

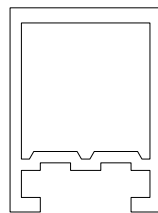

**Ref. SD.100**

*Large vertical span*  
p. 63

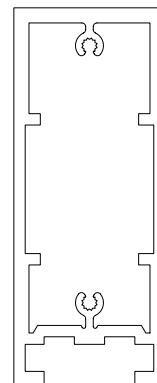

## L.033 < Blade types

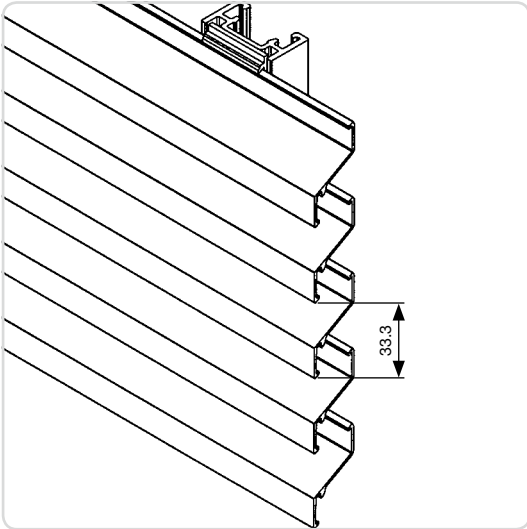

L.033.01

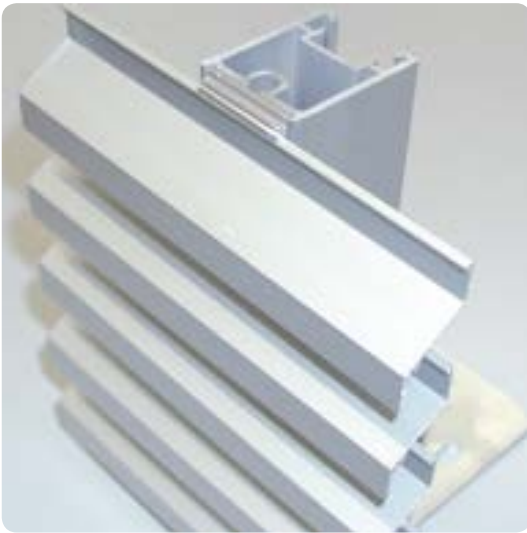

### Extruded aluminium blade

Extruded aluminium profile for light duty with a 33.3 mm pitch. Normally used for smaller surface areas, round and special shapes.

#### Materials

Aluminium extrusion, alloy EN AW 6063 T66

#### Finish

- Anodised (20 micron)
- Polyester powder coating RAL or Syntha Pulvin® colours (60 - 80 µ/40 µ (UK))

#### Mesh

Fixed to rear of the support structure.

#### Features

Blade L.033.01 can also be curved with a minimum radius of 800 mm (see p. 74). Top blade L.033.02 available for attractive top connection. Long bottom blade L.033.03 and short bottom blade L.033.04 for optimal finish.

#### Doors

Single and double doors available with standard RENSON® hardware and rotating on pivot (see p. 71-72)

#### Blade support

- Single blade support: type L.033.11 (width: 30 mm)
- Double blade support for thermal expansion: type L.033.12 (width: 34 mm) (connecting piece for 2 blades)

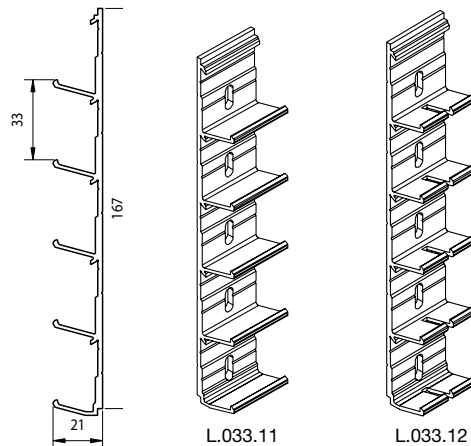

## Technical drawings

L.033.01

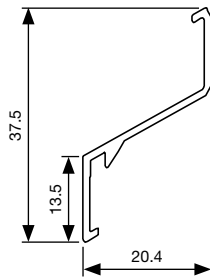

L.033.02

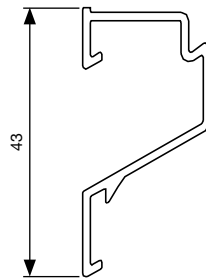

L.033.03

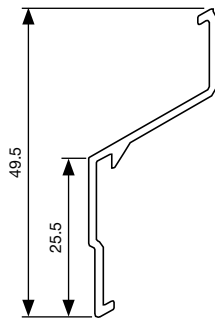

L.033.04

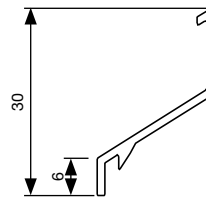

## Technical data

	L.033.01
Pitch	33,3 mm
Depth	20,4 mm
Height	37,5 mm
K-Factor*, supply	22,68
Visual free area*	59%
Physical free area*	44,7%
Max. unsupported span between two mullions**	800 mm

\* Definition see p. 50

\*\* At  $q_b$  800 Pa wind pressure



## L.033 variations < Blade types

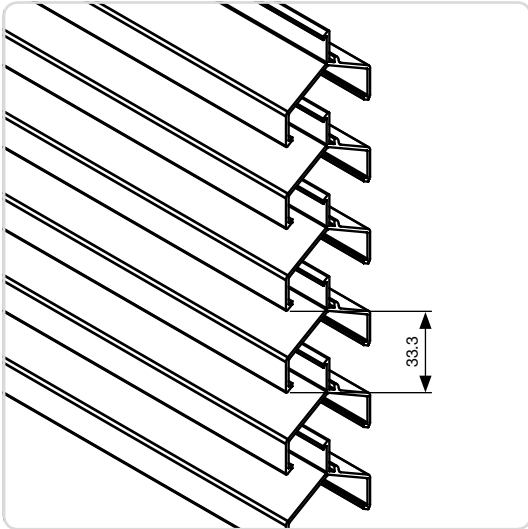

L.033V

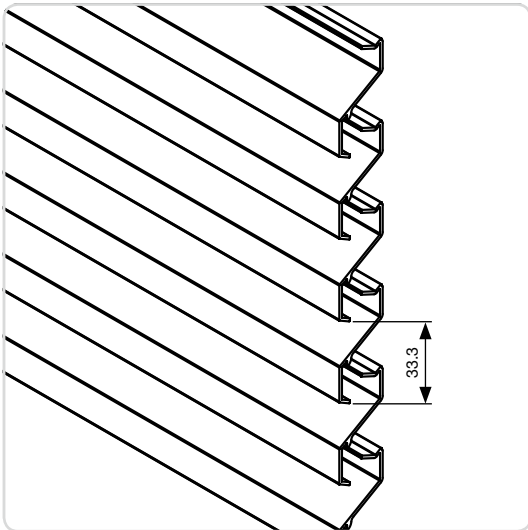

L.033.08



### Extruded aluminium blade

Extruded aluminium profile with a 33.3 mm pitch.

#### Application examples

- L.033V and L.033.08 :
  - High-risk applications, such as high voltage units requiring restricted access
  - Small format for high weather resistance
- (L.033V : HEVAC categorie A)
  - Blade L.033V can be used together with blade L.033.01 thanks to their identical appearance
- L.033HF :
  - Physical free area 50%
- L.033CL :
  - Suitable for fully or partially closed continuous louvre systems

#### Technical drawings

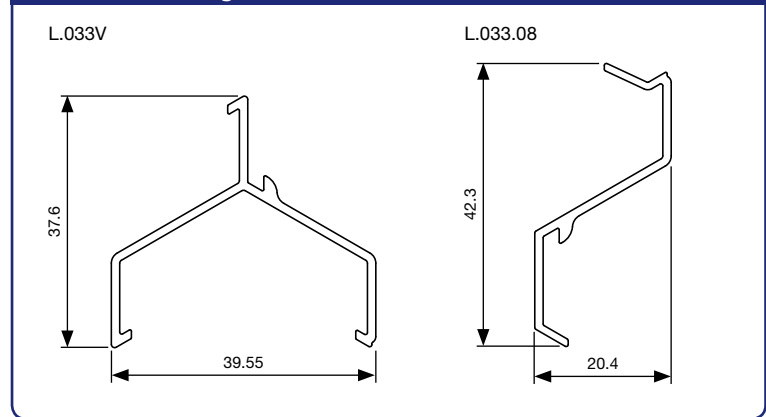

#### Technical data

	L.033V
Pitch	33,3 mm
Depth x Height	39,6 mm x 37,6 mm
K-Factor*, supply	61,04
Visual free area*	60 %
Physical free area*	43 %
Max. unsupported span between two mullions**	800 mm
	L.033.08
Pitch	33,3 mm
Depth x Height	20,4 mm x 42,3 mm
K-Factor*, supply	123,46
Visual free area*	56 %
Physical free area*	26 %
Max. unsupported span between two mullions**	950 mm

\* Definition see p. 50

\*\* At qb 800 Pa wind pressure

## Extruded aluminium blade

Extruded aluminium profile with integrated insect mesh. This 33.3 mm pitch blade clipped into the standard blade support combines weather resistance and insect protection. No separate insect mesh is needed, resulting in considerable time savings during installation. This blade is also the ideal solution for applications where installation of a separate insect mesh is difficult. The L.033IM1 blade combines perfectly with the standard L.033.01 blade and L.033CL closed blade.

### Materials

Aluminium extrusion, alloy EN AW 6063 T66

### Finish

- Anodised (20 micron)
- Polyester powder coating RAL or Syntha Pulvin® colours (60 - 80 µ/40 µ (UK))

### Doors

Single and double doors available with standard RENSON® hardware and rotating on pivot (see p. 71-72).

### Blade support

- Single blade support: type L.033.11 (width: 30 mm)
- Double blade support for thermal expansion: L.033.12 (width: 34 mm) (connecting piece for 2 blades)

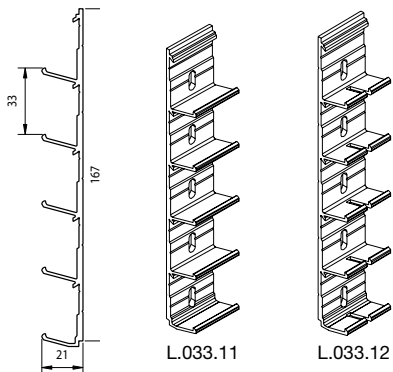

Installation up to x2 faster

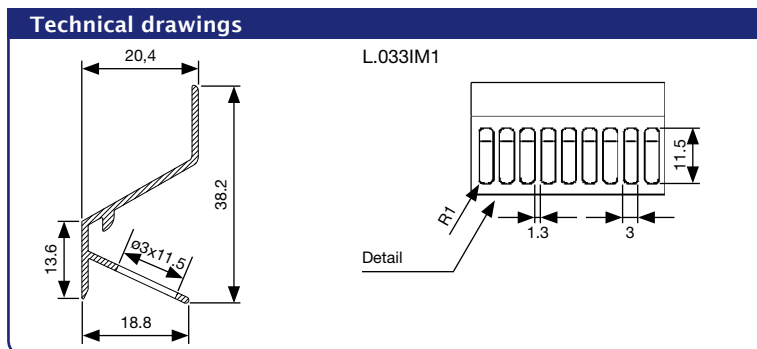

Technical data	
	<b>L.033IM1</b>
Pitch	33,3 mm
Depth	20,4 mm
Height	38,2 mm
K-Factor*, supply	34,7
Visual free area*	59 %
Physical free area*	24 %
Max. unsupported span between two mullions**	1350 mm

\* Definition see p. 50  
 \*\* At qb 800 Pa wind pressure

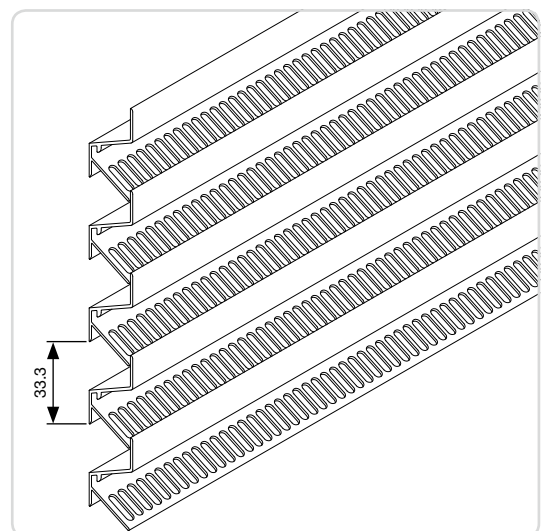

## L.033 variations < Blade types

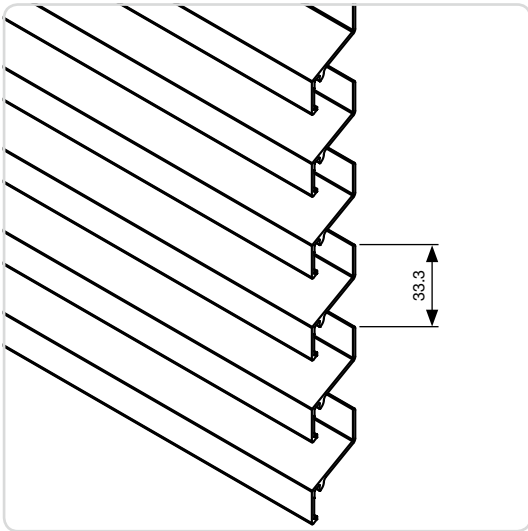

L.033HF

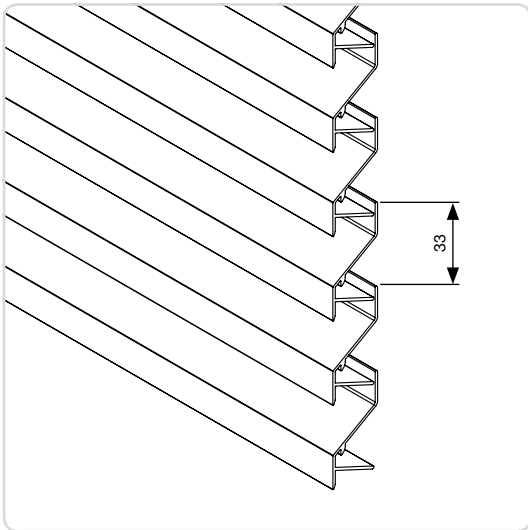

L.033CL

### Extruded aluminium blade

#### Materials

Aluminium extrusion, alloy EN AW 6063 T66

#### Finish

- Anodised (20 micron)
- Polyester powder coating RAL or Syntha Pulvin® colours (60 - 80 µ/40 µ (UK))

#### Mesh

Fixed to the support structure

#### Features

Blade L.033HF can also be curved with a minimum radius of 800 mm (see p. 74).

#### Doors

Single and double doors available with standard RENSON® hardware and rotating on pivot (see p. 71-72)

#### Blade support

- Single blade support: L.033.11 (width: 30 mm)
- Double blade support for thermal expansion: L.033.12 (width: 34 mm) (connecting piece for 2 blades)
- The blade supports are the same for all L.033 blade types. They are only fitted upside down for blade type L.033V.

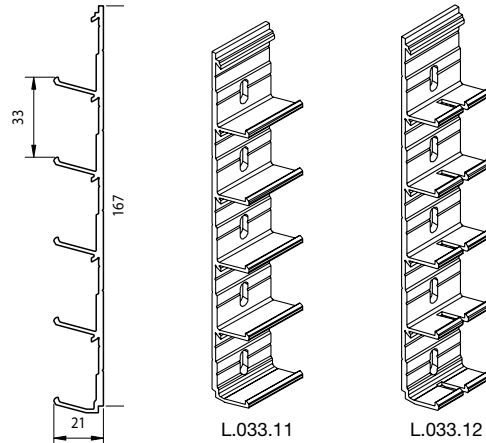

L.033.11

L.033.12



Technical drawings

L.033HF

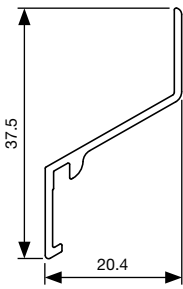

L.033CL

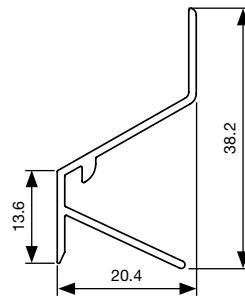

Technical data

	L.033HF
Pitch	33,3 mm
Depth x Height	20,4 mm x 37,5 mm
K-Factor*, supply	22,46
Visual free area*	59 %
Physical free area*	50 %
Max. unsupported span between two mullions**	800 mm
	L.033CL
Pitch	33,3 mm
Depth x Height	20,4 mm x 38,2 mm
Max. unsupported span between two mullions**	1400 mm

\* Definition see p. 50

\*\* At qb 800 Pa wind pressure

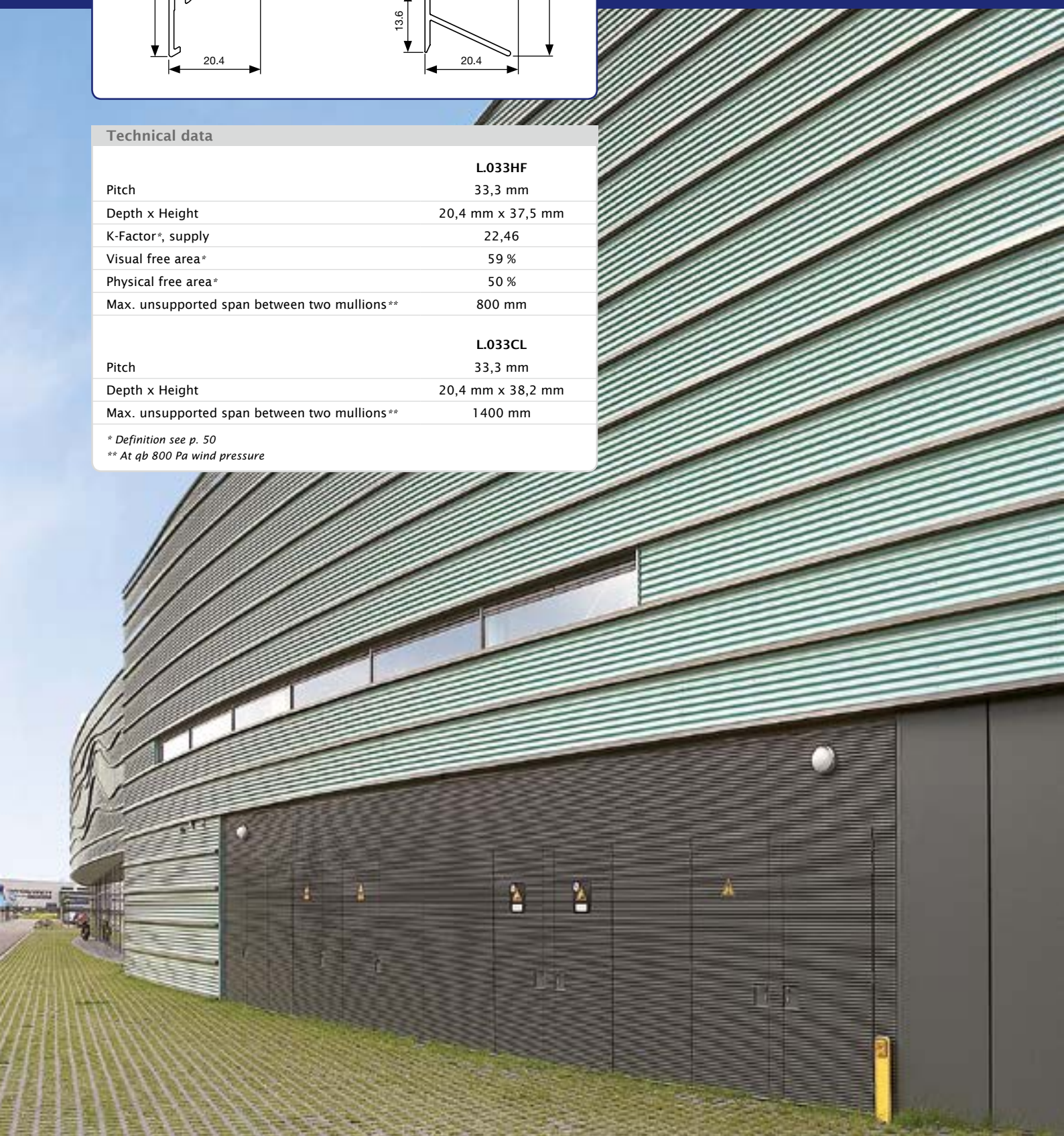

## L.050 < Blade types

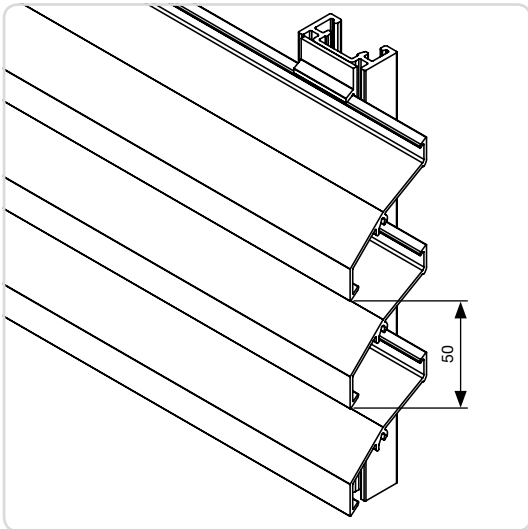

L.050.00

### Extruded aluminium blade

Heavy-duty extruded aluminium profile at 50 mm pitch with very high air flow. Variable 50 to 100 mm pitch is possible with blade supports of the type L.050.13 and L.050.14 (see drawing below).

#### Features

Blade L.050.00 can also be curved with a minimum radius of 800 mm (see p. 74). Top blade L.050.02 available for attractive top connection. Long bottom blade L.050.03 and short bottom blade L.050.04 for optimal finish.

#### Materials

Aluminium extrusion, alloy EN AW 6063 T66

#### Finish

- Anodised (20 micron)
- Polyester powder coating RAL or Syntha Pulvin® colours (60 - 80 µ/40 µ (UK))

#### Mesh

Clipped between the blades (see p. 67) or fixed to the rear of the support structure.

#### Doors

Single and double doors available with standard RENSON® hardware and rotating on pivot (see p. 71-72).

#### Blade support

- Blade supports for 50 mm pitch
- Single blade support: type L.050.110 (width 28 mm)
- Double blade support for thermal expansion: type L.050.120 (width 34 mm) (connection piece for 2 blades)
- Blade supports for variable pitch 50 - 100 mm
- Single blade support: type L.050.13 (width 28 mm)
- Double blade support for thermal expansion: types L.050.14 (width 34 mm) (connection piece for 2 blades)

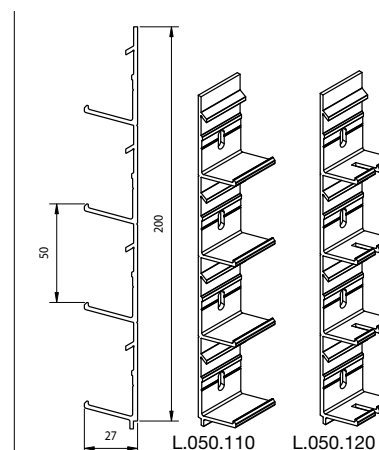
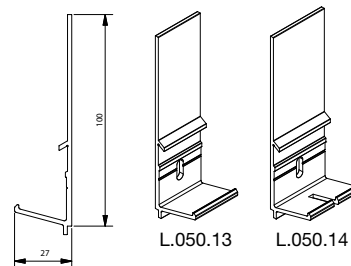

## Technical drawings

L.050.00

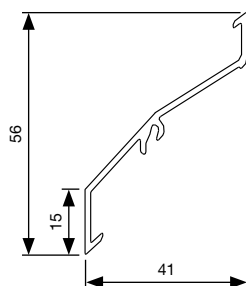

L.050.02

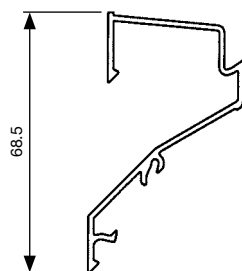

L.050.03

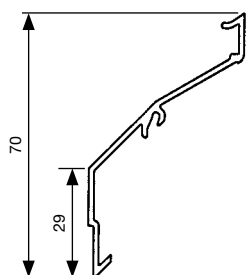

L.050.04

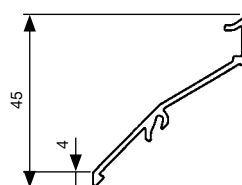

## Technical data

	L.050.00
Pitch	50 mm
Depth	41,0 mm
Height	56,0 mm
K-Factor*, supply	12,57
Visual free area*	70%
Physical free area*	49%
Max. unsupported span between two mullions**	1200 mm

\* Definition see p. 50

\*\* At  $q_b$  800 Pa wind pressure

## L.050HF < Blade types

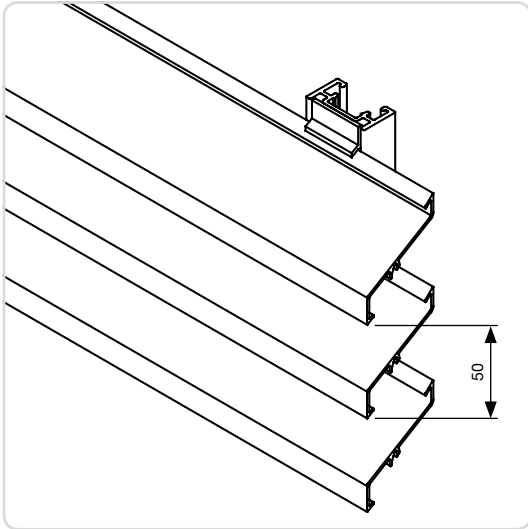

L.050HF

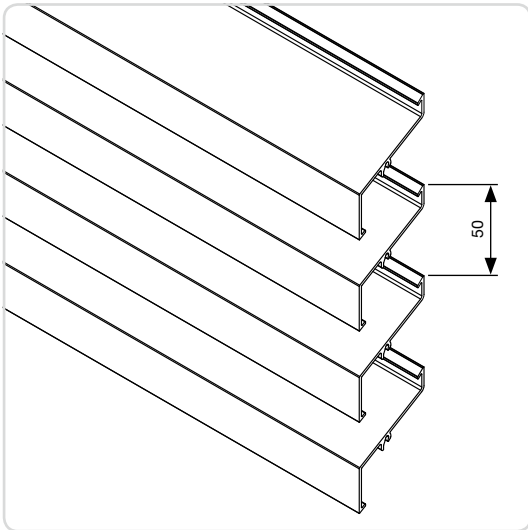

L.050.25



### Extruded aluminium blade

Heavy-duty extruded aluminium profile at 50 mm pitch with very high air flow. Variable 50 to 100 mm pitch is possible with blade supports of the type L.050.13 and L.050.14 (see drawing below). Often to be found where the blade pitch reflects the aesthetics of the overall project design.

#### Materials

Aluminium extrusion, alloy EN AW 6063 T66

#### Finish

- Anodised (20 micron)
- Polyester powder coating RAL or Syntha Pulvin® colours (60 - 80 µ/40 µ (UK))

#### Mesh

Fixed to rear of the support structure.

#### Features

Blade L.050HF can also be curved with a minimum radius of 800 mm (see p. 74).

#### Doors

Single and double doors available with standard RENSON® hardware and rotating on pivot (see p. 71-72)

#### Blade support

- Blade supports for 50 mm pitch
- Single blade support: type L.050.110 (width 28 mm)
- Double blade support for thermal expansion: type L.050.120 (width 34 mm) (connection piece for 2 blades)
- Blade supports for variable pitch 50 - 100 mm
- Single blade support: type L.050.13 (width 28 mm)
- Double blade support for thermal expansion: type L.050.14 (width 34 mm) (connecting piece for 2 blades)

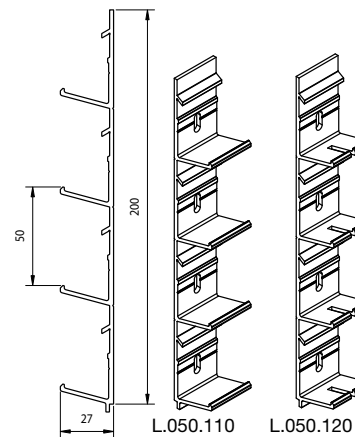

**New!**

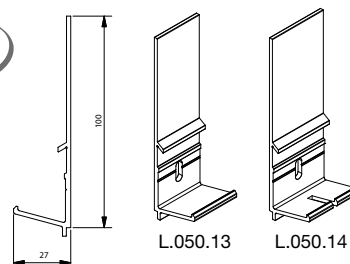

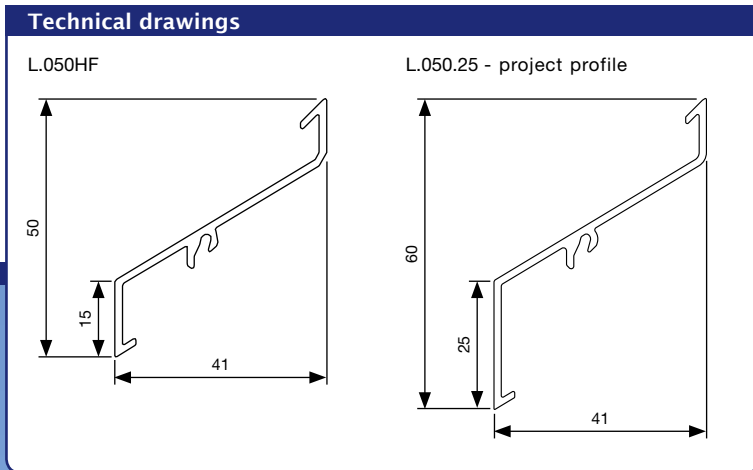

**Technical data**

	<b>L.050HF</b>
Pitch	50 mm
Depth	41,0 mm
Height	50,0 mm
K-Factor*, supply	8,75
Visual free area*	70%
Physical free area*	60%
Max. unsupported span between two mullions**	1050 mm
	<b>L.050.25</b>
Pitch	50 mm
Depth	41,0 mm
Height	60,0 mm
K-Factor*, supply	15,69
Visual free area*	50%
Physical free area*	32,5%
Max. unsupported span between two mullions**	1300 mm

\* Definition see p. 50  
 \*\* At  $q_b$  800 Pa wind pressure

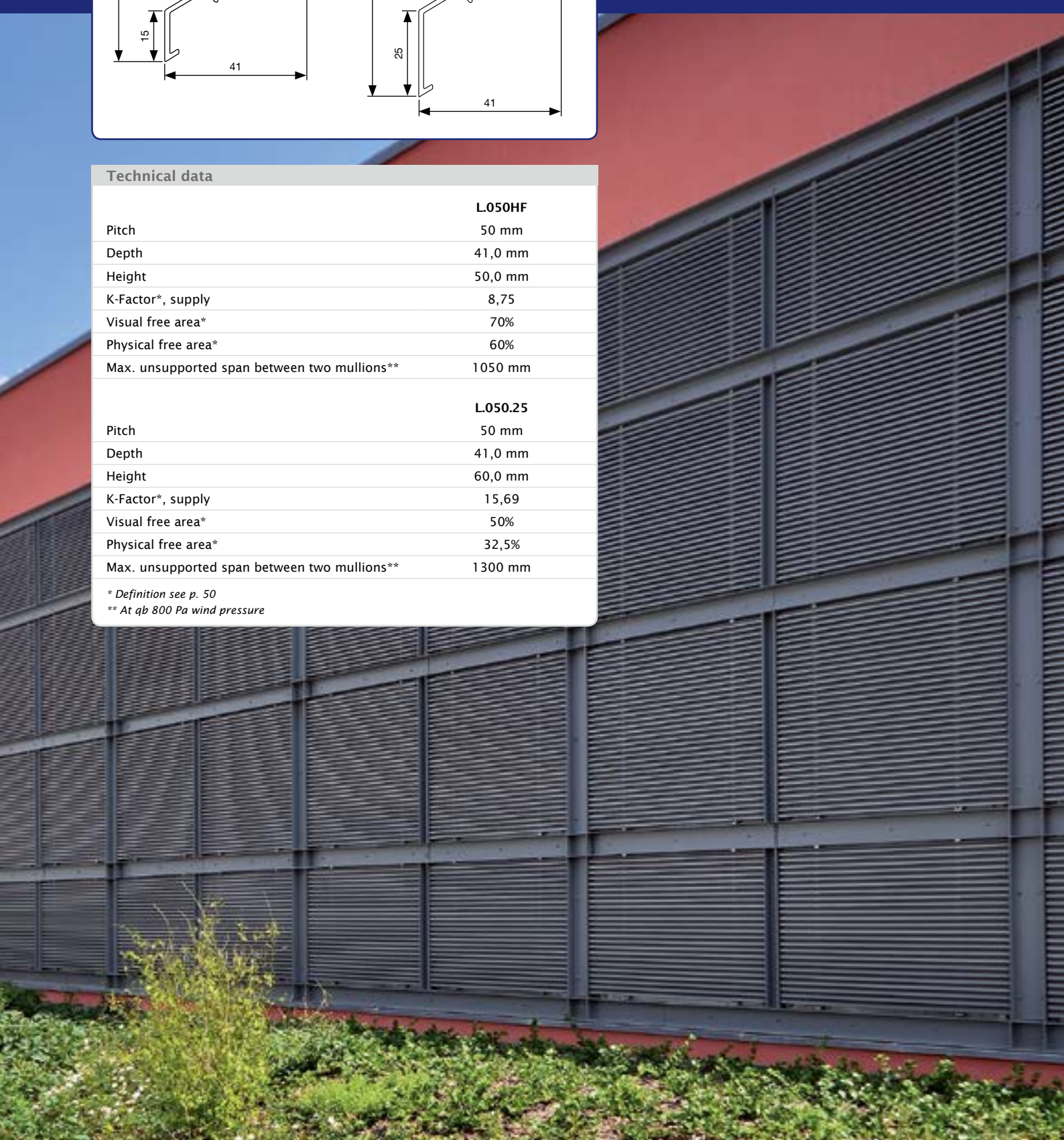

# L.050W / L.050WS < Blade types



*Extruded aluminium blade*

**New!**

## L.050W

The new patented system RENSON® Linius® L.050W is an aesthetically elegant high performance louvre. The system consists of water-resistant blades which have been tested up to 3.0 m/s according to HEVAC class A2 (see p. 52). They are easy to install and barely visible, thanks to being clip mounted to blade supports which accompany the system. Other unique features of this system include excellent air flow, a good physical free area and the blade's large unsupported span between two mullions.

## L.050WS

To provide a matching aesthetic blade, the L.050WS blade is available as part of the system. The blade can be used for non active areas or where high performance without weather resistance is required. Visually the two systems appear the same.

## Materials

Aluminium extrusion, alloy EN AW 6063 T66

## Finish

- Anodised (20 micron)
- Polyester powder coating RAL or Syntha Pulvin® colours (60 - 80 µ/40 µ (UK))



## Blade support L.050W

- Single blade support: type L.050W.11 (width: 28 mm)
- Double blade support for thermal expansion: type L.050W.12 (width: 34 mm) (connecting piece for 2 blades)

## Blade support L.050WS

- Single blade support: type L.050.110
- Double blade support for thermal expansion: type L.050.120

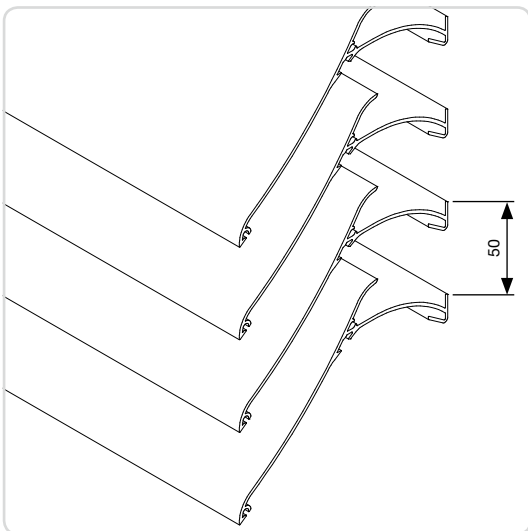

L.050W

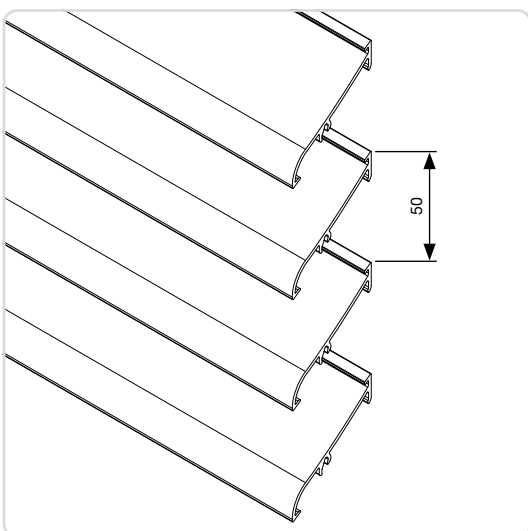

L.050WS

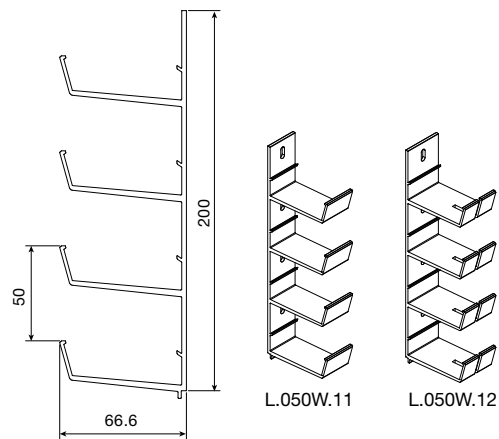

L.050W.11

L.050W.12

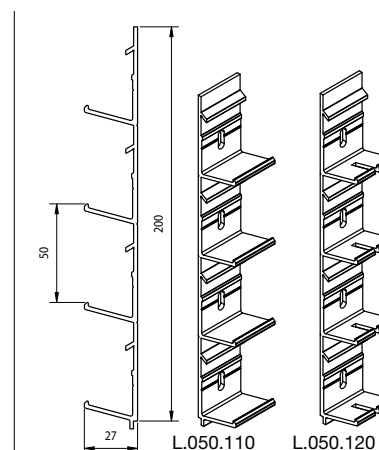

L.050.110

L.050.120

Technical drawings

L.050W

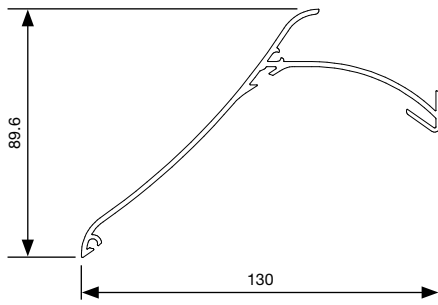

L.050WS

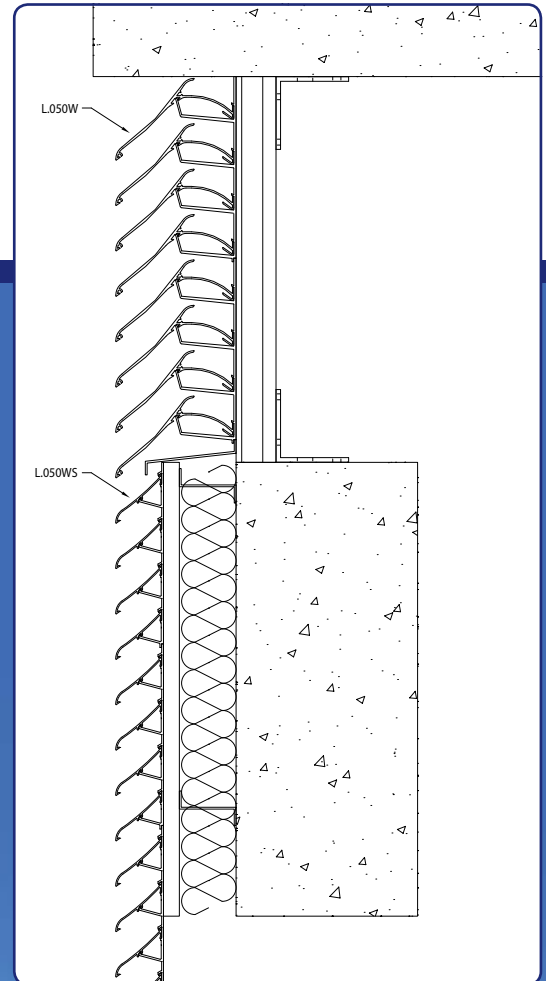
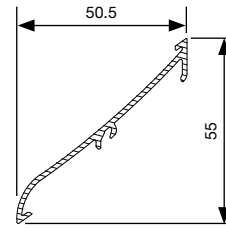

Technical data

	L.050W
Pitch	50 mm
Depth	130 mm
Height	90 mm
Watertightness	A2 tem 3,0m/s
Physical free area	57%
K-Factor*, supply	10,47
C <sub>e</sub> -coefficient	0,309
C <sub>d</sub> -coefficient	0,246
Max. unsupported span between two mullions**	1900 mm

	L.050WS
Pitch	50 mm
Depth	50 mm
Height	55 mm
Watertightness	-
Physical free area	59%
K-Factor*, supply	6,09
C <sub>e</sub> -coefficient	0,406
C <sub>d</sub> -coefficient	0,382
Max. unsupported span between two mullions**	950 mm

\* Definition see p. 50

\*\* At q<sub>b</sub> 800 Pa wind pressure

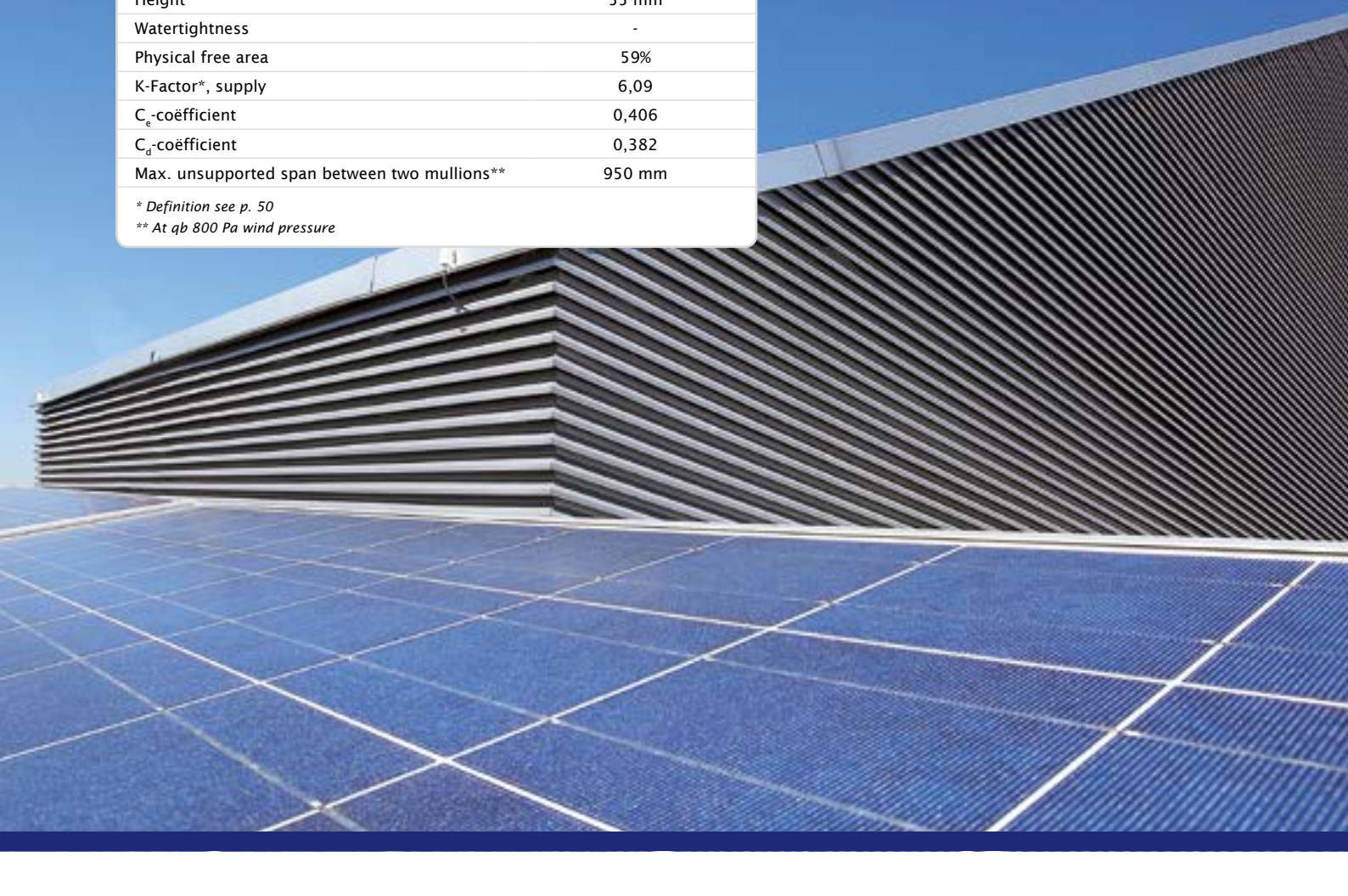

## L.050CL < Blade types

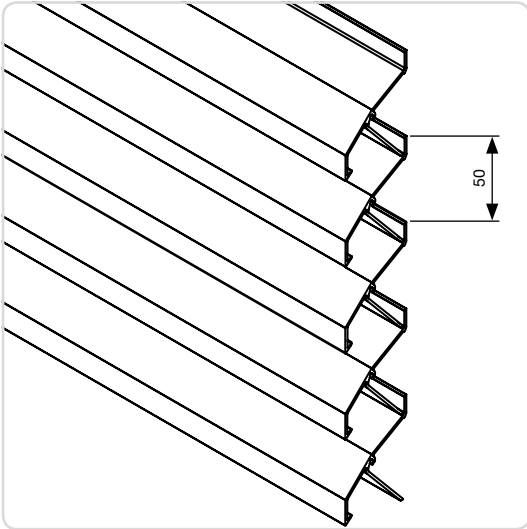

L.050CL



### Extruded aluminium blade

#### Applications

Often used in cases where the step between the blades display the aesthetics of the project design. Available as doors, shapes and circles.  
L.050CL - Suitable for fully or partially closed continuous louvre systems.

#### Materials

Aluminium extrusion, alloy EN AW 6063 T66

#### Finish

- Anodised (20 micron)
- Polyester powder coating RAL or Syntha Pulvin® colours (60 - 80 µ/40 µ (UK))

#### Doors

Single and double doors available with standard RENSON® hardware and rotating on pivot (see p. 71-72).

#### Blade support

- Single blade support: type L.050.110 (width: 28 mm)
- Double blade support for thermal expansion: L.050.120 (width: 34 mm) (connecting piece for 2 blades)

#### Technical drawing

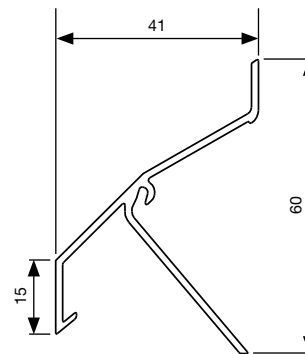

#### Technical data

	L.050CL
Pitch	50 mm
Depth x Height	41 x 60
Max. unsupported span between two mullions**	2100 mm
* Definition see p. 50	
** At qb 800 Pa wind pressure	

### Extruded aluminium blade

Extruded aluminium louvre profile with minimal air flow resistance. Particularly suitable where a large airflow is required in combination with considerable optical density and a sharp design.

#### Materials

Aluminium extrusion, alloy EN AW 6063 T66

#### Finish

- Anodised (20 micron)
- Polyester powder coating RAL or Syntha Pulvin® colours (60 - 80 µ/40 µ (UK))

#### Mesh

Fixed to rear of the support structure.

#### Doors

Single and double doors available with standard RENSON® hardware and rotating on pivot (see p. 71-72)

#### Blade support

- Single blade support: type L.060HF.11 (width 28 mm)
- Double blade support for thermal expansion: L.060HF.12 (connecting piece for 2 blades) (width 34 mm)

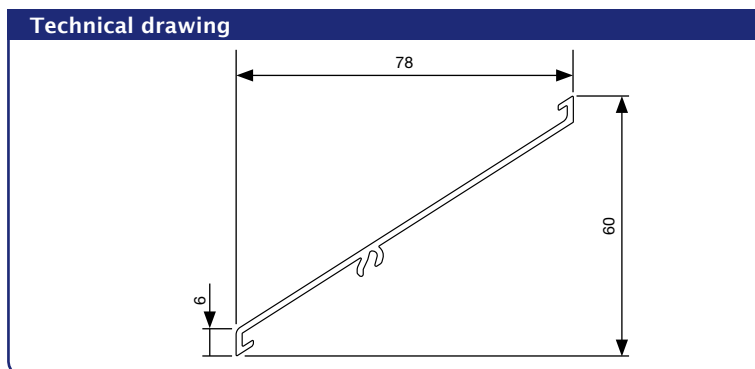
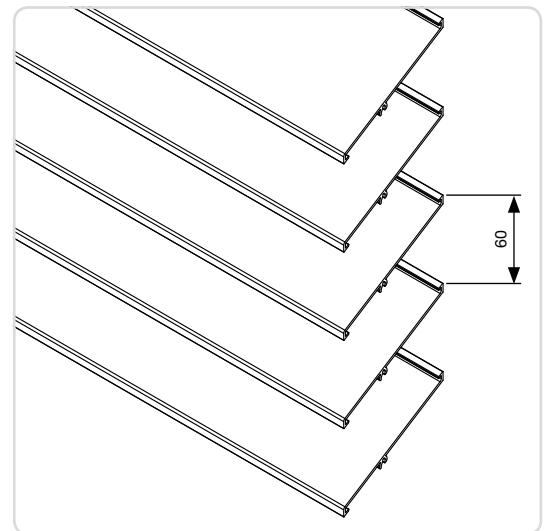
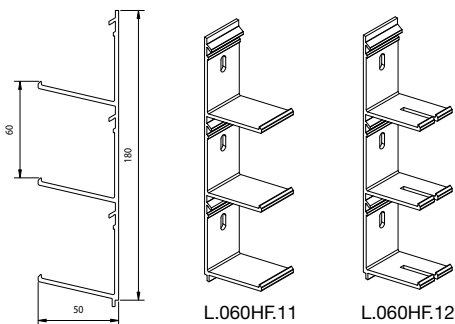

#### Technical data

	L.060HF
Pitch	60 mm
Depth	78 mm
Height	60 mm
K-Factor*, supply	5,03
K-Factor*, extraction	4,96
Visual free area*	90%
Physical free area*	76%
Max. unsupported span between two mullions**	800 mm

\* Definition see p. 50  
\*\* At qb 800 Pa wind pressure



## L.066 < Blade types

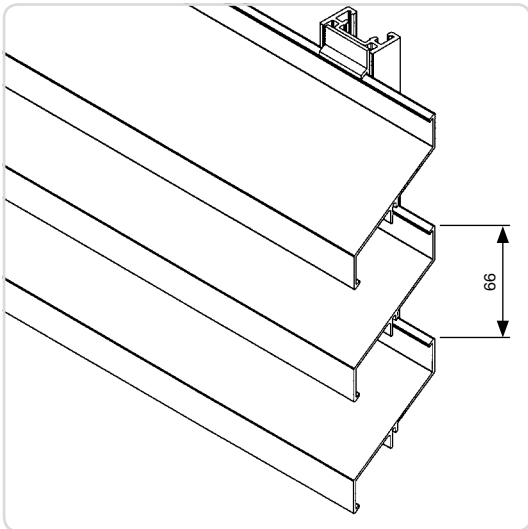

L.066.01

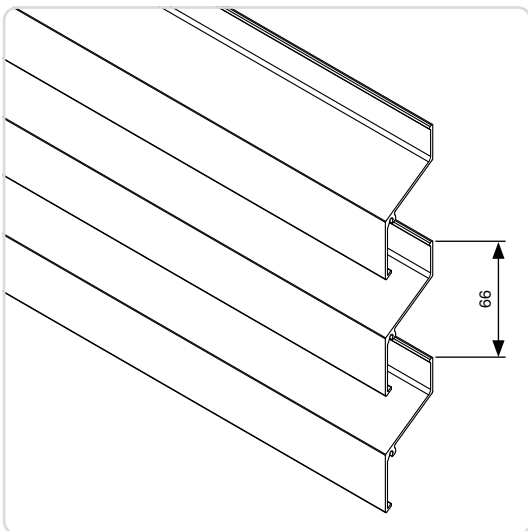

L.066.06

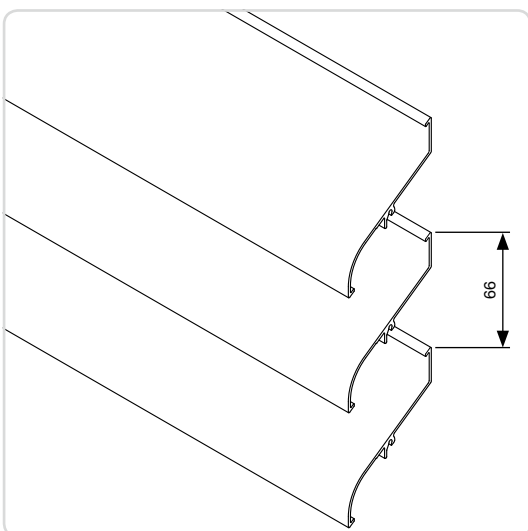

L.066S

### Extruded aluminium blade

Heavy-duty extruded aluminium profile at 66 mm pitch with high air flow. Variable 66 to 132 mm pitch is possible with blade supports of the type L.066.13 and L.066.14 (see drawing below). Blade L.066.02 available for nice top finish.

#### Materials

Aluminium extrusion, alloy EN AW 6063 T66

#### Finish

- Anodised (20 micron)
- Polyester powder coating RAL or Syntha Pulvin® colours (60 - 80 µ/40 µ (UK))

#### Mesh

Fixed to rear of the support structure.

#### Doors

Single and double doors available with standard RENSON® hardware and rotating on pivot (see p. 71-72).

#### Blade support

- Blade supports for 66 mm pitch
- Single blade support: type L.066.11 (width 28 mm)
- Double blade support for thermal expansion: type L.066.12 (width 34 mm) (connection piece for 2 blades)
- Blade supports for variable pitch 66 - 132 mm
- Single blade support: type L.066.13 (width 28 mm)
- Double blade support for thermal expansion: type L.066.14 (width 34 mm) (connecting piece for 2 blades)

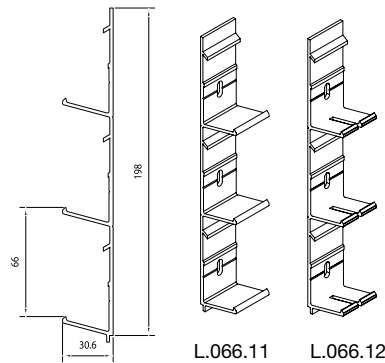

L.066.11

L.066.12

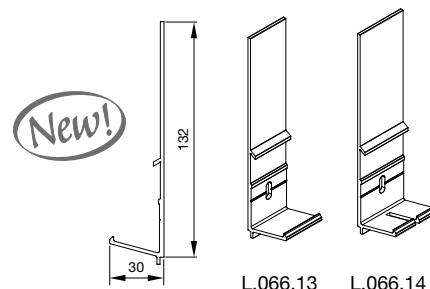

L.066.13

L.066.14

## Technical drawings

L.066.01

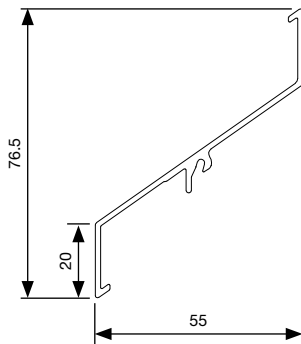

L.066.02

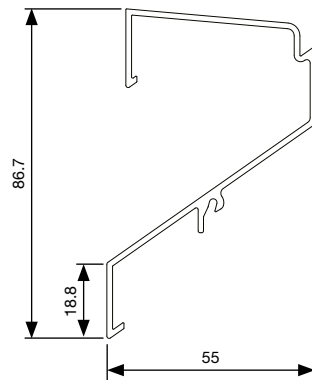

L.066.06

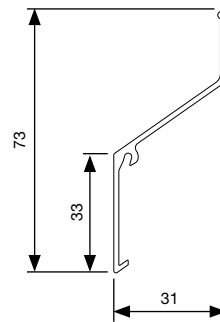

L.066S - project profile

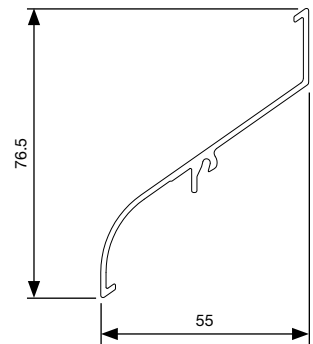

## Technical data

	L.066.01
Pitch	66 mm
Depth	55,0 mm
Height	76,5 mm
K-Factor*, supply	13,62
Visual free area*	70%
Physical free area*	49,2%
Max. unsupported span between two mullions**	1600 mm

	L.066.06
Pitch	66 mm
Depth	31 mm
Height	73 mm
K-Factor*, supply	29,11
Visual free area*	50%
Physical free area*	38%
Max. unsupported span between two mullions**	1500 mm

	L.066S
Pitch	66 mm
Depth	55,0 mm
Height	76,5 mm
K-Factor*, supply	13,62
Visual free area*	70%
Physical free area*	49%
Max. unsupported span between two mullions**	1600 mm

\* Definition see p. 50

\*\* At  $q_b$  800 Pa wind pressure

## L.066CL < Blade types



### Extruded aluminium blade

The largest of the “small” format louvres retaining high air flow characteristics whilst providing a significant degree of weatherability.  
L.066CL - Suitable for fully or partially closed continuous louver systems.

#### Finish

- Anodised (20 micron)
- Polyester powder coating RAL or Syntha Pulvin® colours (60 - 80 µ/40 µ (UK))

#### Doors

Single and double doors available with standard RENSON® hardware and rotating on pivot (see p. 71-72)

#### Blade support

- Single blade support: type L.066.11 (width: 28 mm)
- Double blade support for thermal expansion: L.066.12 (width: 34 mm) (connecting piece for 2 blades)

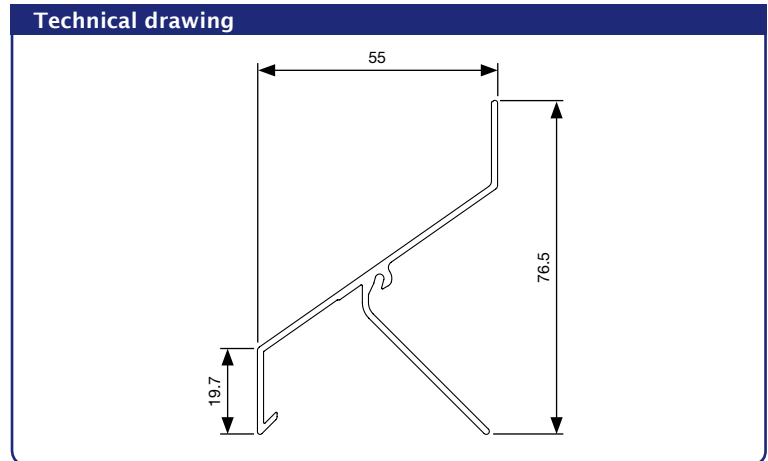
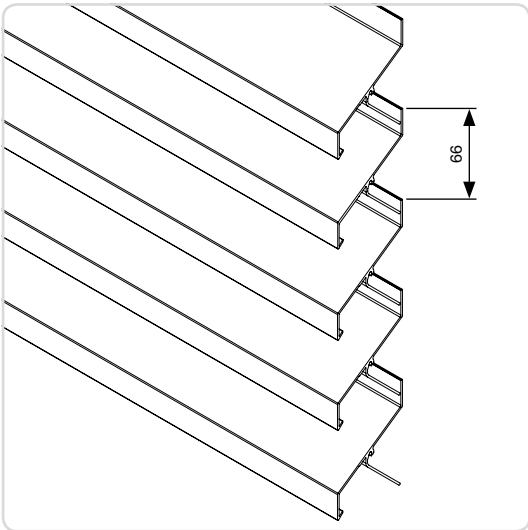

#### Technical data

	L.066CL
Pitch	66 mm
Depth x Height	55 x 76,5
Max. unsupported span between two mullions**	2300 mm

\* Definition see p. 50

\*\* At qb 800 Pa wind pressure



*Extruded aluminium blade*

Extruded aluminium profile with integrated insect mesh. This 66 mm pitch blade clipped into the standard blade support combines weather resistance and insect protection. No separate insect mesh is needed, resulting in considerable time savings during installation. This blade is also the ideal solution for applications where installation of a separate insect mesh is difficult. The L.033IM1 blade combines perfectly with the standard L.066.01 blade and L.066CL closed blade.

**Materials**

Aluminium extrusion, alloy EN AW 6063 T66

**Finish**

- Anodised (20 micron)
- Polyester powder coating RAL or Syntha Pulvin® colours (60 - 80 µ/40 µ (UK))

**Doors**

Single and double doors available with standard RENSON® hardware and rotating on pivot (see p. 71-72).

**Blade support**

- Single blade support: type L.066.11 (width: 28 mm)
- Double blade support for thermal expansion: L.066.12 (width: 34 mm) (connecting piece for 2 blades)

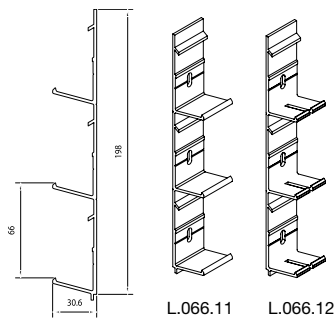

Installation up to x2 faster

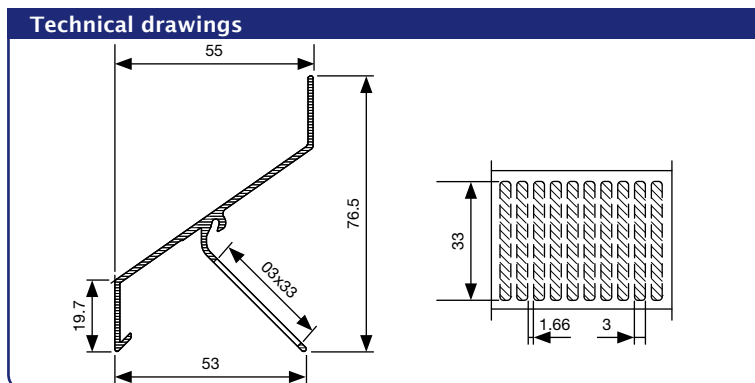
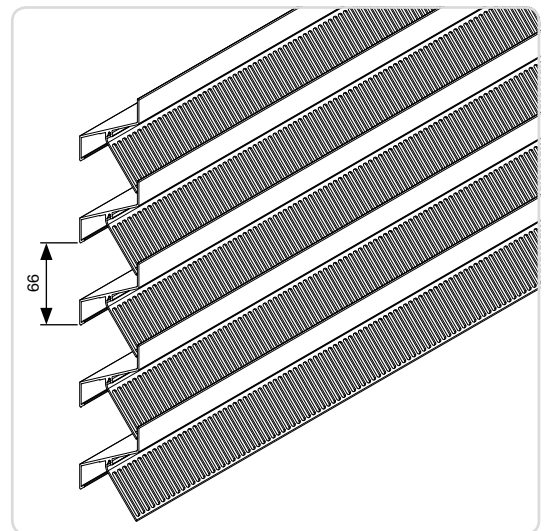

Technical data		L.066IM1
Pitch		66 mm
Depth		55 mm
Height		76,5 mm
K-Factor*, supply		17,58
Visual free area*		70 %
Physical free area*		32 %
Max. unsupported span between two mullions**		2300 mm

\* Definition see p. 50  
 \*\* At qb 800 Pa wind pressure



## L.066V < Blade types

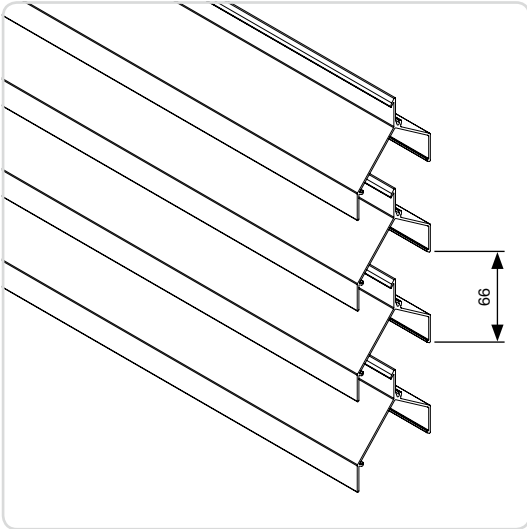

### Extruded aluminium blade

Extruded aluminium V-shape profile with a 66 mm pitch. For applications requiring restricted access, such as in high voltage units, or visual screen and high water-resistance. If a continuous louvre wall with high water-tightness properties is required, the blade is installed vertically to achieve HEVAC class A water resistance at 1.5 m/s (see p. 52). Blade L.066V can be combined with blade L.066 thanks to their identical appearance.

### Materials

Aluminium extrusion, alloy EN AW 6063 T66

### Finish

- Anodised (20 micron)
- Polyester powder coating RAL or Syntha Pulvin® colours (60 - 80 µ/40 µ (UK))

### Mesh

Fixed to rear of the support structure.

### Doors

Single and double doors available with standard RENSON® hardware and rotating on pivot (see p. 71-72)

### Blade support

- Single blade support: type L.066.11 (width: 28 mm)
- Double blade support for thermal expansion: L.066.12 (width: 34 mm) (connecting piece for 2 blades)
- The blade supports are the same for all L.066 blade types. They are only fitted upside down for blade type L.066V.

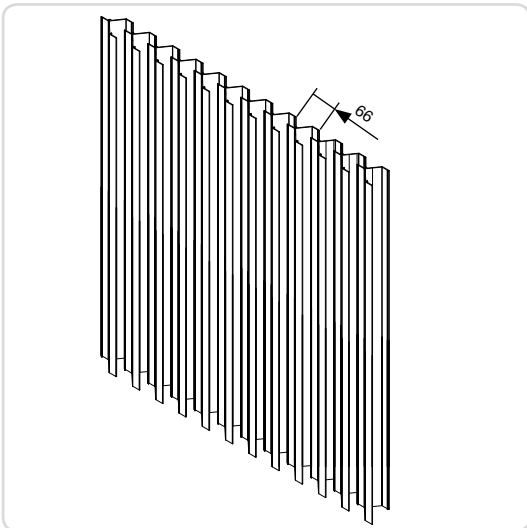

L.066V - vertical blades

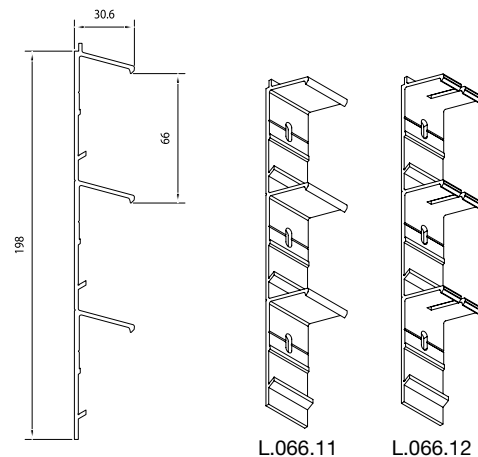

## Technical drawing

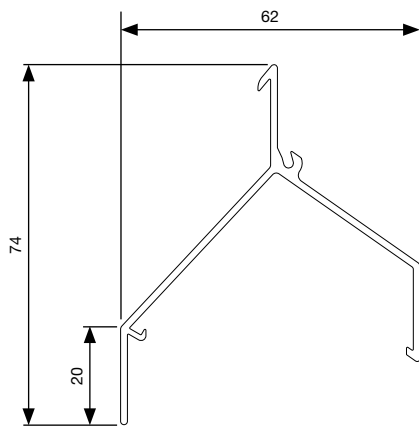

## Technical data

	L.066V
Pitch	66 mm
Depth	61,5 mm
Height	74 mm
K-Factor*, supply	66,10
K-Factor*, extraction	79,72
Visual free area*	70%
Physical free area*	40,6%
Max. unsupported span between two mullions**	1650 mm

\* Definition see p. 50

\*\* At  $q_b$  800 Pa wind pressure

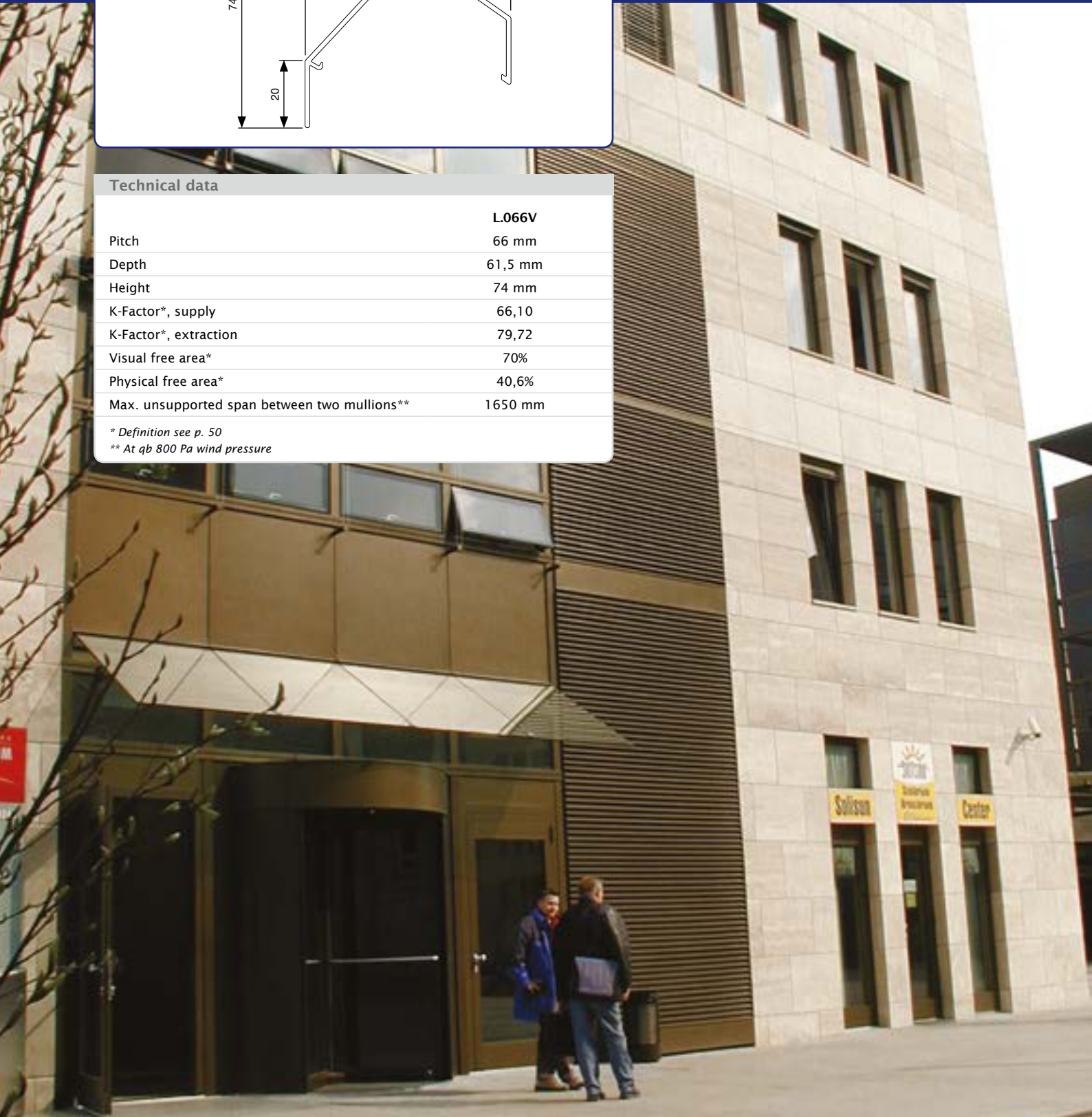

## L.075 < Blade types

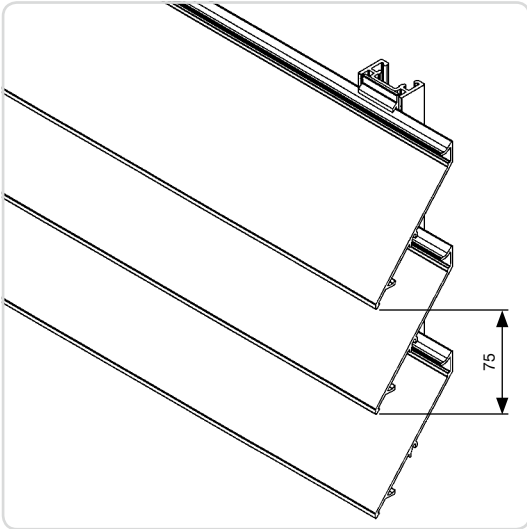

L.075.01

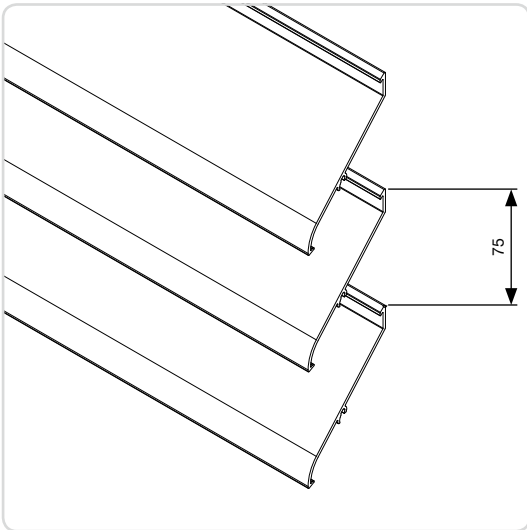

L.075.12



### Extruded aluminium blade

Heavy duty extruded aluminium profile with an optimal air flow and a 75 mm pitch. This latest innovation in the RENSON® range is available with a wide range of mesh options to handle all kinds of circumstances.

#### Materials

Aluminium extrusion, alloy EN AW 6063 T66

#### Finish

- Anodised (20 micron)
- Polyester powder coating RAL or Syntha Pulvin® colours (60 - 80 µ/40 µ (UK))

#### Mesh

Clicked between the blades (see p. 67), or fixed to the rear of the support structure.

#### Features

- Top blade L.075.02 for optimal finish
- Lower blade L.075.03 for optimal sill lining
- Frame without flange (see p. 70)
- Frame with flange (see p. 70)

#### Doors

Single and double doors available with standard RENSON® hardware and rotating on pivot (see p. 71-72)

#### Blade support

- Single blade support: type L.075.11 (width: 28 mm)
- Double blade support for thermal expansion: L.075.12 (width: 34 mm) (connecting piece for 2 blades)

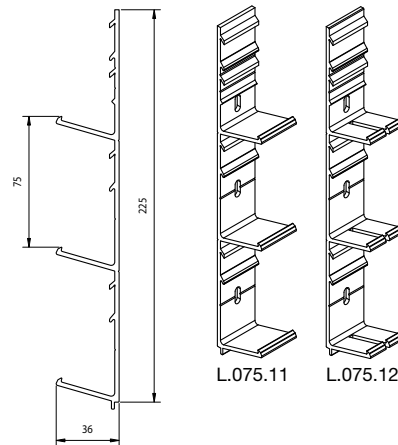

## Technical drawings

L.075.01

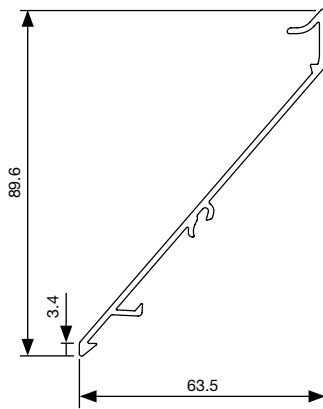

L.075.02

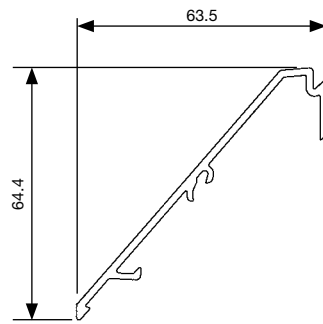

L.075.03

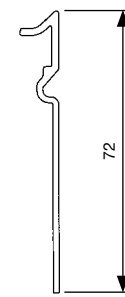

L.075S - project profile

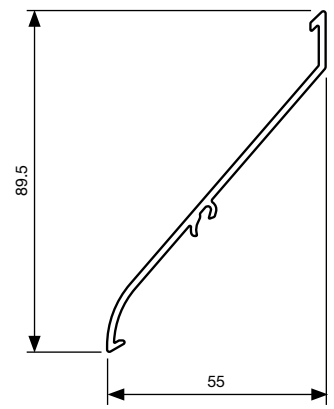

## Technical data

	L.075.01
Pitch	75 mm
Depth	63,5 mm
Height	89,6 mm
K-Factor*, supply	16,52
Visual free area*	94%
Physical free area*	43%
Max. unsupported span between two mullions**	1100 mm
	L.075S
Pitch	75 mm
Depth	55 mm
Height	89,5 mm
K-Factor*, supply	16,52
Physical free area*	46,5%
Max. unsupported span between two mullions**	1000 mm

\* Definition see p. 50

\*\* At  $q_b$  800 Pa wind pressure

## L.095 < Blade types

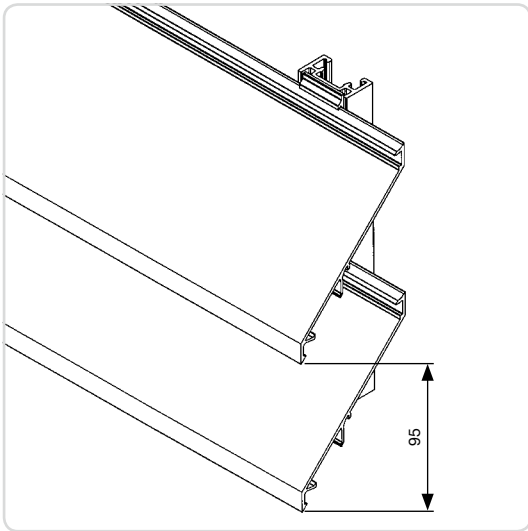

### *Extruded aluminium blade*

Extra heavy-duty extruded aluminium blade with high free airflow and a pitch of 95 mm.

#### **Materials**

Aluminium extrusion, alloy EN AW 6063 T66

#### **Finish**

- Anodised (20 micron)
- Polyester powder coating RAL or Syntha Pulvin® colours (60 - 80 µ/40 µ (UK))

#### **Mesh**

Clicked between the blades (see p. 67), or fixed to the rear of the support structure.

#### **Doors**

Single and double doors available with standard RENSON® hardware and rotating on pivot (see p. 71-72)

#### **Blade support**

- Single blade support: type L.095.11 (width: 28 mm)
- Double blade support for thermal expansion: L.095.12 (width: 34 mm) (connecting piece for 2 blades)

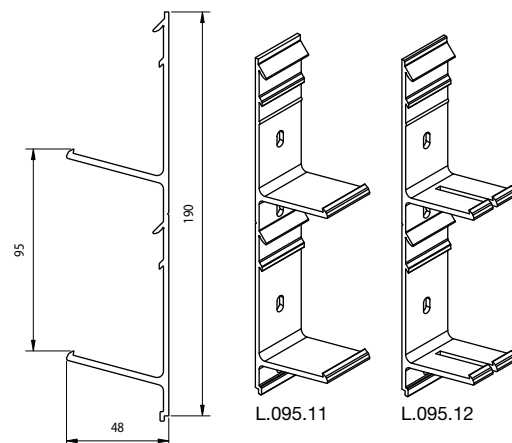

## Technical drawings

L.095.01

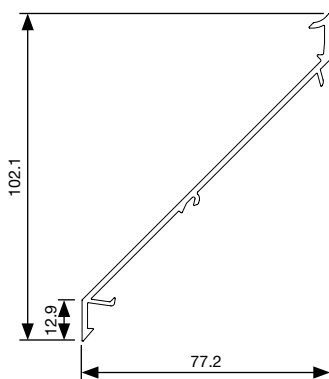

L.095S - project profile

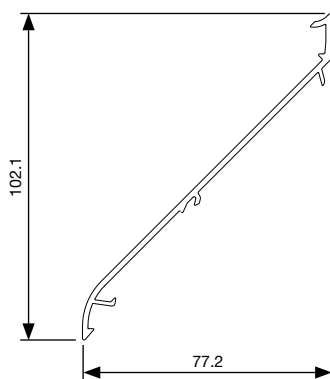

## Technical data

	L.095
Pitch	95 mm
Depth	77,2 mm
Height	102,1 mm
K-Factor*, supply	11,41
Visual free area*	86%
Physical free area*	55,5%
Max. unsupported span between two mullions**	1300 mm

	L.095S
Pitch	95 mm
Depth	77,2 mm
Height	102,1 mm
K-Factor*, supply	9,70
Physical free area*	55%
Max. unsupported span between two mullions**	1300 mm

\* Definition see p. 50

\*\* At  $q_b$  800 Pa wind pressure

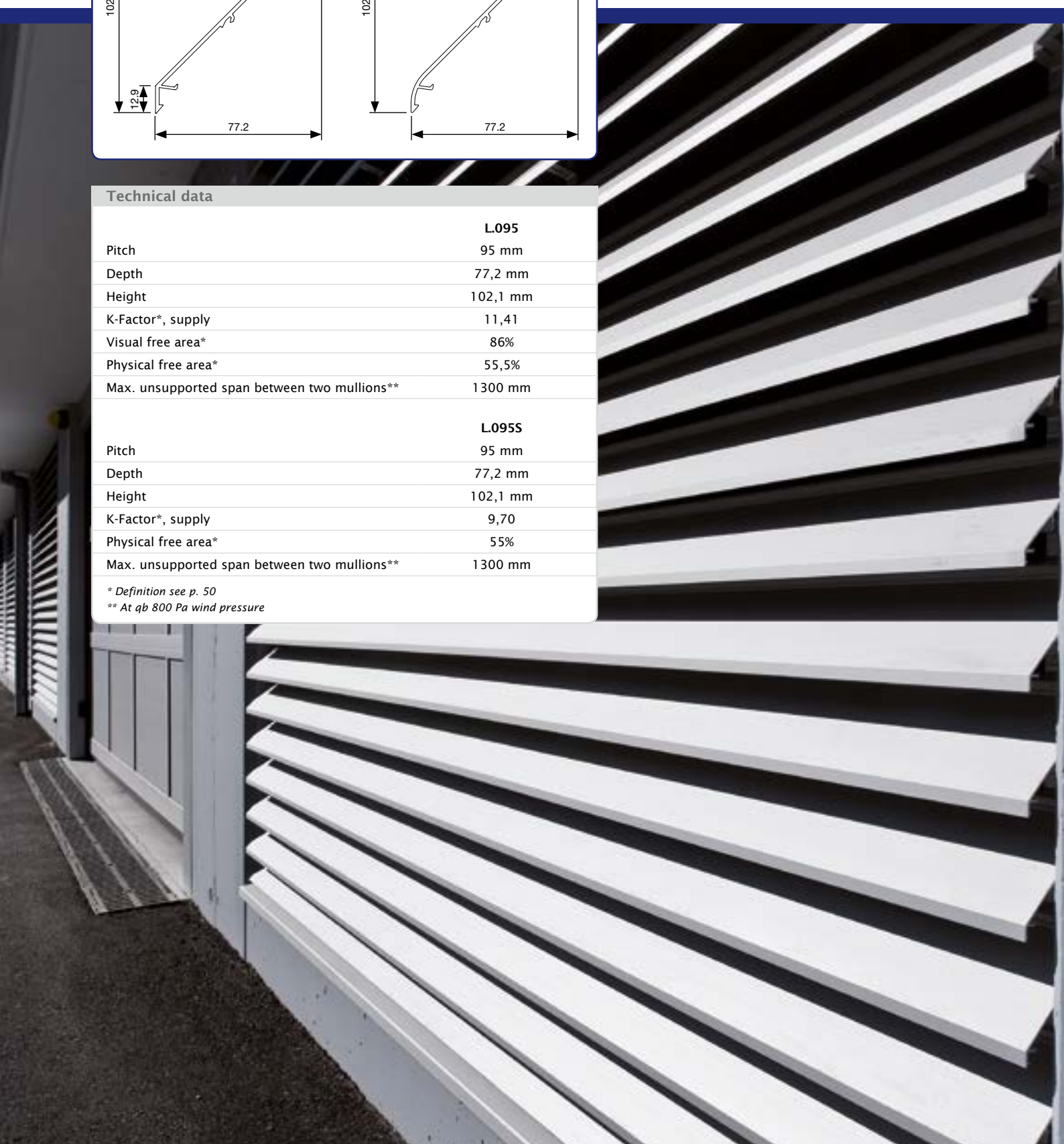

## L.120 < Blade types



### Extruded aluminium blade

Extruded aluminium profile for large spans at 120 mm pitch with an optimal air flow. Improved installation speed thanks to a small number of clips and blades.

#### Materials

Aluminium extrusion, alloy EN AW 6063 T66

#### Finish

- Anodised (20 micron)
- Polyester powder coating RAL or Syntha Pulvin® colours (60 - 80 µ/40 µ (UK))

#### Mesh

Fixed to rear of the support structure.

#### Doors

Single and double doors available with standard RENSON® hardware and rotating on pivot (see p. 71-72)

#### Blade support

- Single blade support: Type L.120.11 (width: 28 mm)
- Double blade support for thermal expansion: L.120.12 (width: 34 mm) (connecting piece for 2 blades)
- Blade supports for variable pitches 120-240 mm
- Single blade support: type L.120.13 (width 28 mm)
- Double blade support for thermal expansion: type L.120.14 (width 34 mm) (connecting piece for 2 blades)

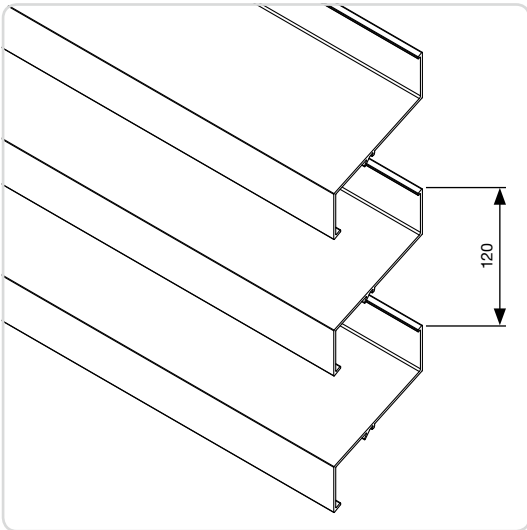

Installation up to x2 faster

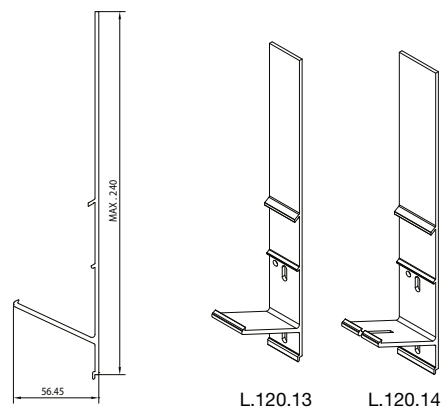
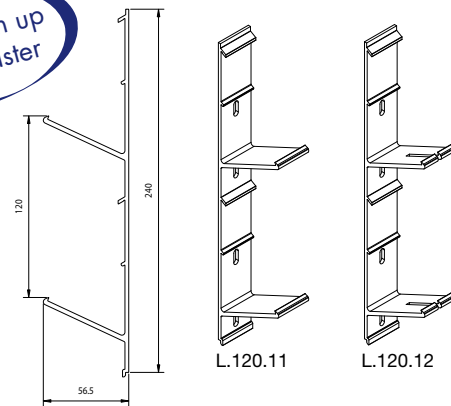

## Technical drawing

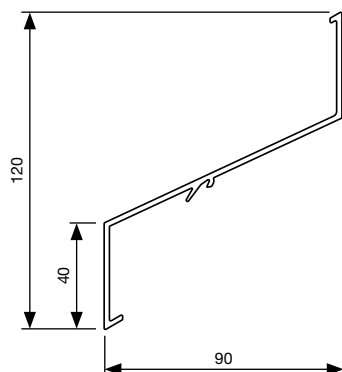

## Technical data

	L.120
Pitch	120 mm
Depth	90 mm
Height	120 mm
K-Factor*, supply	13,82
K-Factor*, extraction	14,68
Visual free area*	66%
Physical free area*	60%
Max. unsupported span between two mullions**	2300 mm

\* Definition see p. 50

\*\* At  $q_b$  800 Pa wind pressure



# L.065AL / L.065GL / L.065STS < Blade types

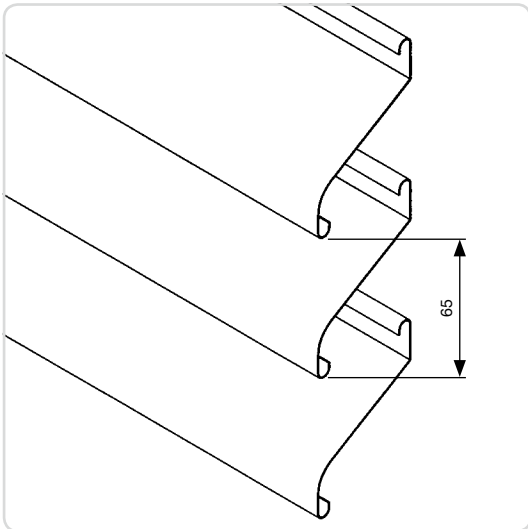

## Rolled blades

Rolled aluminium profile (L.065AL); rolled aluminium profile, perforated (L.065AL .02) galvanized steel (L.065GL) or stainless steel (L.065StS). Light duty strip material with a pitch of 65 mm and resistance to normal weather conditions. For use as a screen, ideal if a low-priced solution is required. Mounted with a soft flowing appearance (M1) or with front corner line (M2).

### Materials

- Aluminium EN AW 3005-H18
- Galvanised steel EN 10142
- Stainless steel

### Finish

Polyester powder coating RAL or Syntha Pulvin® colours (60 - 80 µ/40 µ (UK)) - (only for L.065AL)

### Mesh

Fixed to rear of the support structure.

### Doors

Only with L.065AL

### Blade support

- Type L.065AL:
  - Single blade support type L.065AL.11 (width: 28 mm)
  - Double blade support type L.065AL.12 (width: 45 mm) (connecting piece for 2 blades)
- Type L.065GL & StS:
  - Single blade support type L.065GL.11 (width: 28 mm)
  - Double blade support type L.065GL.12 (width: 45 mm) (connecting piece for 2 blades)

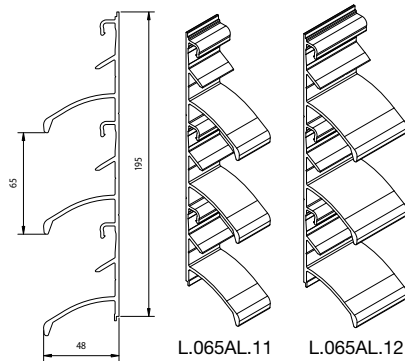
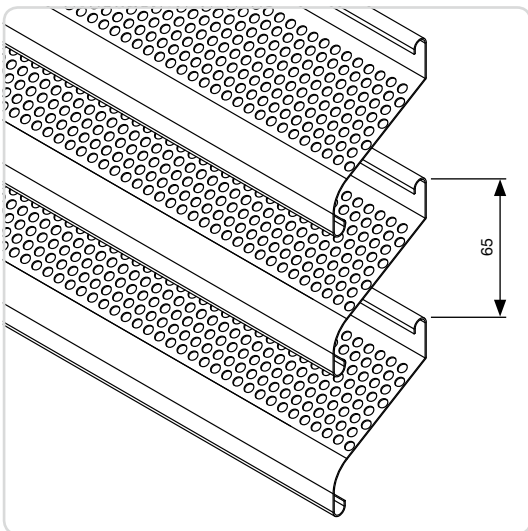

L.065AL

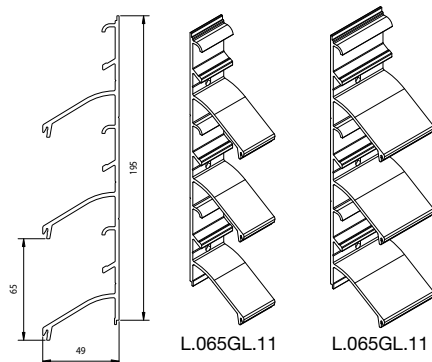

L.065GL

Technical drawings

Type L.065: 2 fastening options

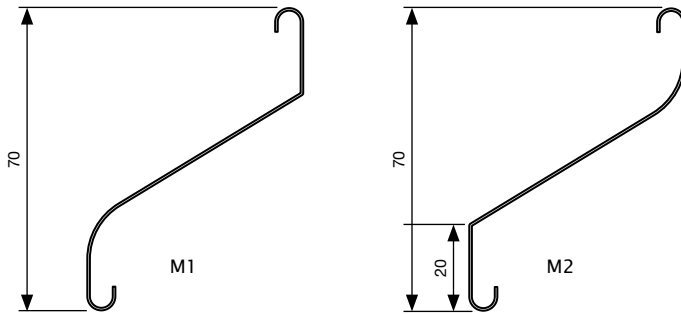

Technical data

	L.065AL, GL & STS
Pitch	65 mm
Depth	50,0 mm
Height	70,0 mm
K-Factor*, supply	13,32
Visual free area*	70%
Physical free area*	56%
Max. unsupported span between two mullions**	1200 mm

\* Definition see p. 50

\*\* At  $q_b$  800 Pa wind pressure



## L.060AC < Blade types



### *Extruded aluminium acoustic blade*

Extruded aluminium profile with a pitch of 60 mm and perforated back; maximum blade length of 6,000 mm. Blades packed with inorganic mineral wool for acoustic performance. Developed to provide an aesthetic solution for noise reducing continuous louvre applications.

#### **Materials**

Extruded aluminium, EN AW-6063 T66, mineral wool, perforated PVC strip.

#### **Finish**

- Anodised (20 micron)
- Polyester powder coating RAL or Syntha Pulvin® colours (60 - 80 µ/40 µ (UK))

#### **Mesh**

Fixed to rear of the support structure.

#### **Doors**

Single and double doors available with standard RENSON® hardware and rotating on pivot (see p. 71-72)

#### **Acoustic properties**

L.060AC:  $R_w (C; C_{tr}) = 6 (1; -2)$  dB

#### **Blade support**

- L.060AC : Single blade support: type L.060AC.11 (width: 28 mm)
- Double blade support for thermal expansion: L.060AC.12 (width: 45 mm) (connecting piece for 2 blades)

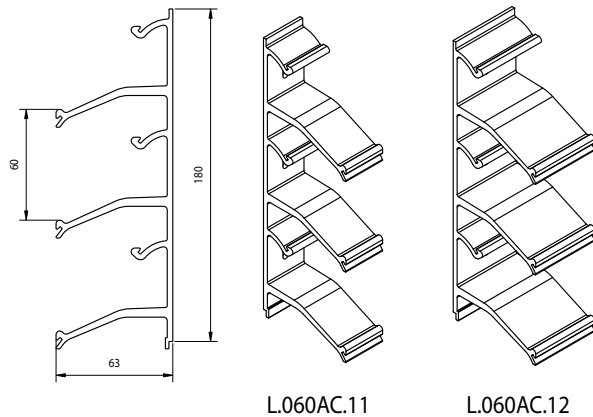
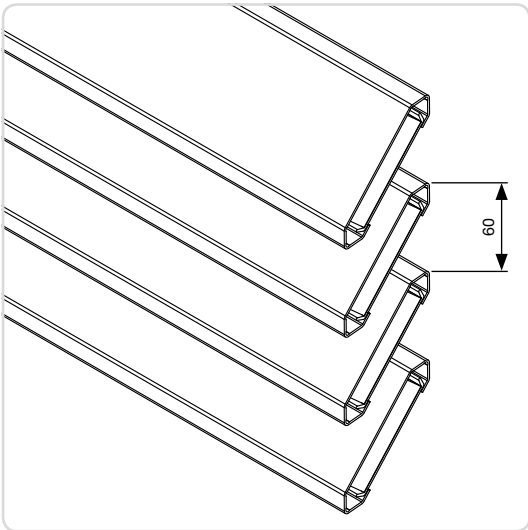

L.060AC.11

L.060AC.12

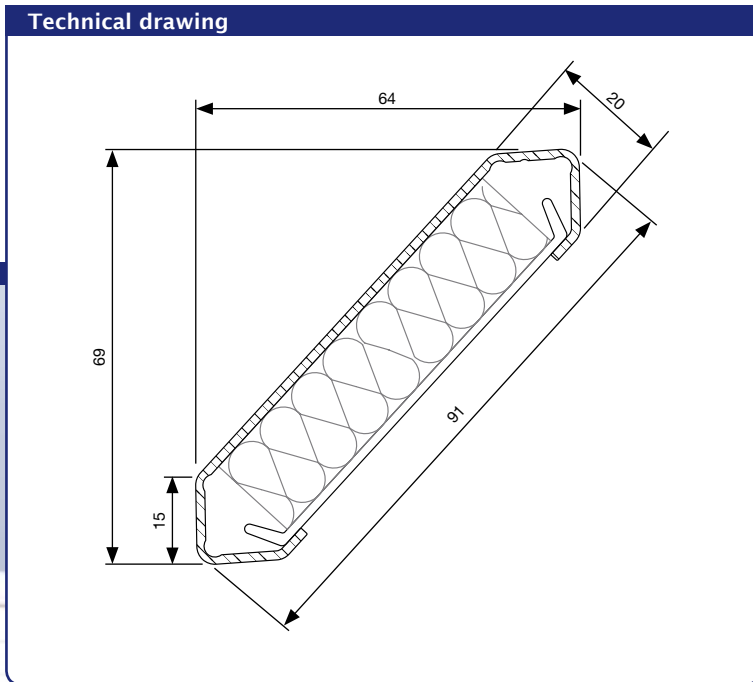

#### Technical data

	L.060AC
Pitch	60 mm
Depth	64 mm
Height	69 mm
K-Factor*	9,22
Visual free area*	75 %
Physical free area*	34 %
Max. unsupported span between two mullions**	1700 mm

\* Definition see p. 50

\*\* At  $q_b$  800 Pa wind pressure

# L.150ACS / L.170ACS / L.150ACL / L.170ACL < Blade types



L.150ACS

## Extruded aluminium blade

Extruded aluminium profile with a pitch of 150 mm and perforated underside; maximum blade length of 6,000 mm. Blades packed with inorganic mineral wool for acoustic performance. Developed to provide an aesthetic solution for noise reducing continuous louvre applications.

### Materials

- L.150ACS and L.150ACL : extruded aluminium, EN AW - 6063 T66, perforated aluminium sheet.

### Finish

- Anodised (20 micron)
- Polyester powder coating RAL or Syntha Pulvin® colours (60 - 80 µ/40 µ (UK))

### Mesh

Fixed to rear of the support structure.

### Doors

Single and double doors available with standard RENSON® hardware and rotating on pivot (see p. 71-72)

### Acoustic properties

- L.150ACS:  $R_w(C;C_{tr}) = 11 (-1;-2)$  dB
- L.170ACS:  $R_w(C;C_{tr}) = 9 (0;-1)$  dB
- L.150ACL:  $R_w(C;C_{tr}) = 15 (-1;-4)$  dB
- L.170ACL:  $R_w(C;C_{tr}) = 13 (-1;-3)$  dB

### Blade support

- L.150ACS: type L.150ACS.11
- L.170ACS: type L.170ACS.11
- L.150ACL: type L.150ACL.11
- L.170ACL: type L.170ACL.11



L.150ACL

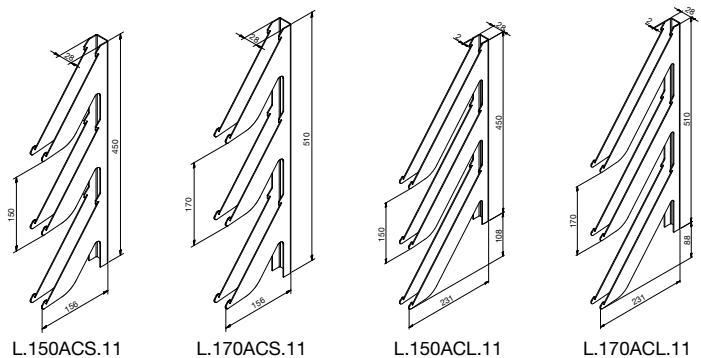

# Blade types > L.150ACS / L.170ACS / L.150ACL / L.170ACL

## Technical drawings

L.150ACS.01

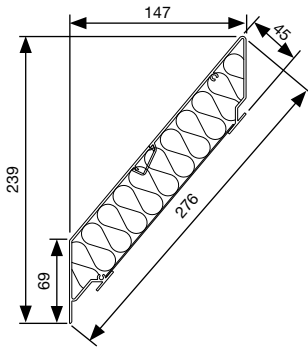

L.150ACL.01

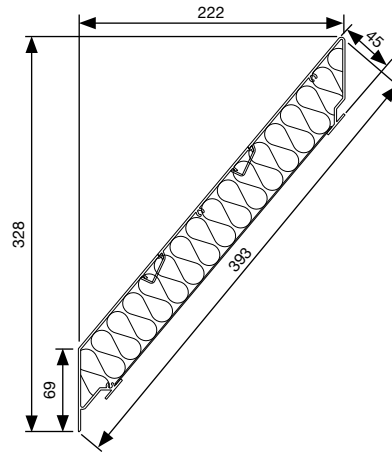

## Technical data

	L.150ACS
Pitch	150 mm
Depth	147 mm
Height	239 mm
K-Factor*, supply	27,4
Visual free area*	54%
Physical free area*	34,3%
Max. unsupported span between two mullions**	2800 mm

	L.170ACS
Pitch	170 mm
Depth	147 mm
Height	239 mm
K-Factor*, supply	25,4
Visual free area*	59%
Physical free area*	37%
Max. unsupported span between two mullions**	2800 mm

	L.150ACL
Pitch	150 mm
Depth	222 mm
Height	328 mm
K-Factor*, supply	37,3
Visual free area*	54%
Physical free area*	34,3%
Max. unsupported span between two mullions**	2700 mm

	L.170ACL
Pitch	170 mm
Depth	222 mm
Height	328 mm
K-Factor*, supply	28,58
Visual free area*	59%
Physical free area*	37%
Max. unsupported span between two mullions**	2700 mm

\* Definition see p. 50

\*\* At  $q_b$  800 Pa wind pressure



## L.150DAC / L.170DAC < Blade types



### Extruded aluminium blade

Extruded aluminum profile with a step of 150 or 170 mm, according acoustic system (\*). This can be perfectly combined with the acoustic blades L.150ACS.01 / L.150ACL.01, on places in the wall where no acoustic damping is required.

#### Materials

- Extruded aluminium, EN AW - 6063 T66

#### Finish

- Anodised (20 micron)
- Polyester powder coating RAL or Syntha Pulvin® colours (60 - 80 µ/40 µ (UK))

#### Blade support

- Single blade support: type L.150.11 or L.170.11 (\*)
- Double blade support for thermal expansion: type L.150.12 or L.170.12 (\*)

(\*) pitch of the blade according to system L.150DAC of L.170DAC

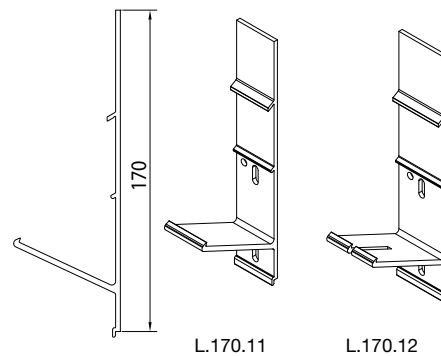
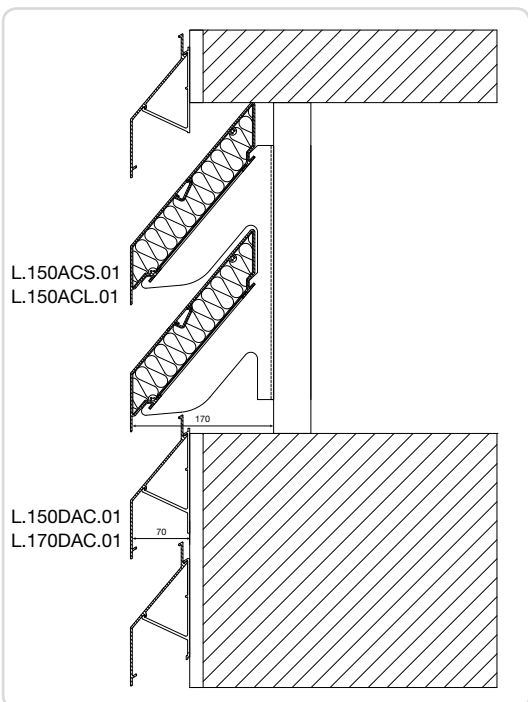
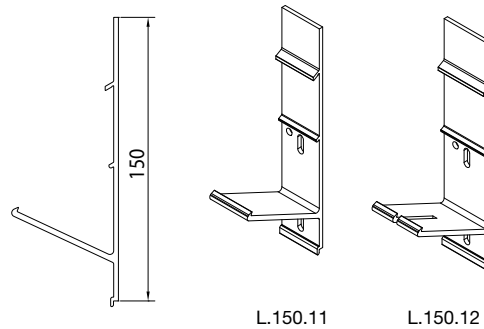
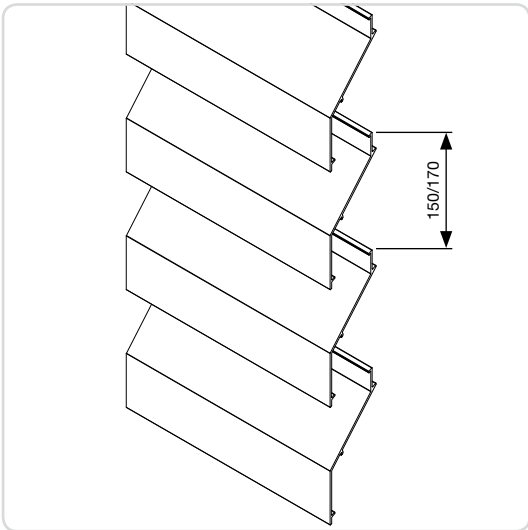

Technical drawing

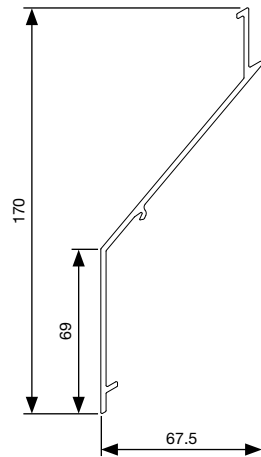

Technical data

	L.150DAC	L.170DAC
Pitch	150 mm	170 mm
Depth	67,5 mm	
Height	170 mm	
Physical free area*	34%	37%
K-Factor*, supply	47,7	42,47
K-Factor*, extraction	41,08	37,58
Max. unsupported span between two mullions**	ca. 2.400mm	

\* Definition see p. 50

\*\* At  $q_b$  800 Pa wind pressure



## L.066P < Blade types



### *Extruded aluminium blade*

The Linius® L.066P Plano type is characterised by its unique and contemporary design. Linius® Plano blades are rectangular extruded aluminium blades. The system can be used for different purposes. It offers the opportunity to create modern architectural constructions in a simple way, both outside and inside.

#### **Applications**

- Sunshading blades
- Visual screen
- Aesthetic cladding
- Both exterior and interior applications
- Room divider
- Ceiling covering
- Integration in Loggia® type sunshading panels

#### **Materials**

- Aluminium extrusion, alloy EN AW 6063 T66

#### **Finish**

- Anodised (20 micron)
- Polyester powder coating RAL or Syntha Pulvin® colours (60 - 80 µ/40 µ (UK))

#### **Blade support**

- Single blade support: L.066P.11 (width: 28 mm)
- Double blade support for thermal expansion: L.066P.12 (width: 34 mm) (connecting piece for 2 blades)

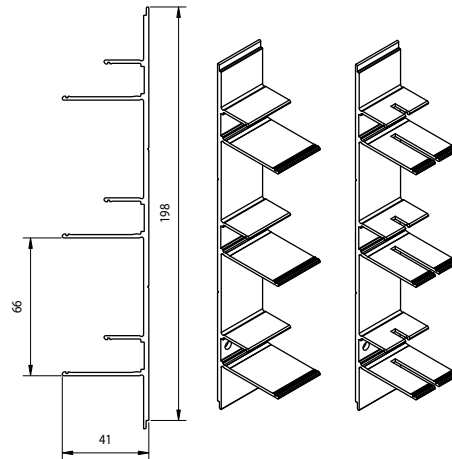
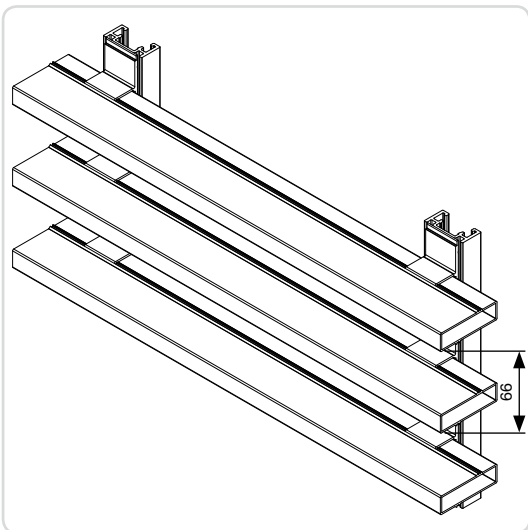

## Technical drawing

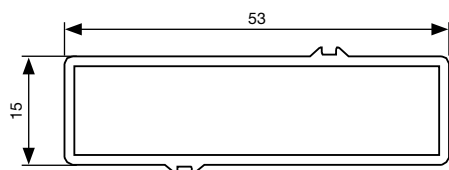

## Technical data

	L.066P
Pitch	66 mm
Depth	53 mm
Height	15 mm
Visual free area*	77 %
Physical free area*	77 %
Max. unsupported span between two mullions**	800 mm

\* Definition see p. 50

\*\* At  $q_b$  800 Pa wind pressure



# Aesthetic blades for cladding/sunprotection < Blade types

Extruded aluminium profile at standard 50 mm (L.050.21) and 66 mm (L.066.21) pitch. Variable 50 to 100 mm pitch (L.050.21) is possible with blade supports types L.050.13 and L.050.14 (L.050.21). Variable 66 to 132 mm pitch (L.066.21) is possible with blade supports of the type L.066.13 and L.066.14 (L.066.21) - see drawing below. Can be used as an aesthetic façade cladding, sun protection or visual barrier.

## Materials

- Aluminium extrusion, alloy EN AW 6063 T66

## Finish

- Anodised (20 micron)
- Polyester powder coating RAL or Syntha Pulvin® colours (60 - 80 µ/40 µ (UK))

## Mesh

Fixed to rear of the support structure.

## Doors

Single and double doors available with standard RENSON® hardware and rotating on pivot (see p. 71-72)

## Blade support

- L.050.21 : single blade support: type L.050.11 (width: 28 mm)
- Double blade support for thermal expansion: L.050.12 (width: 34 mm) (connecting piece for 2 blades)
- L.066.21 : blade support: type L.066.11 (width: 28 mm)
- Double blade support for thermal expansion: L.066.12 (width: 34 mm) (connecting piece for 2 blades)

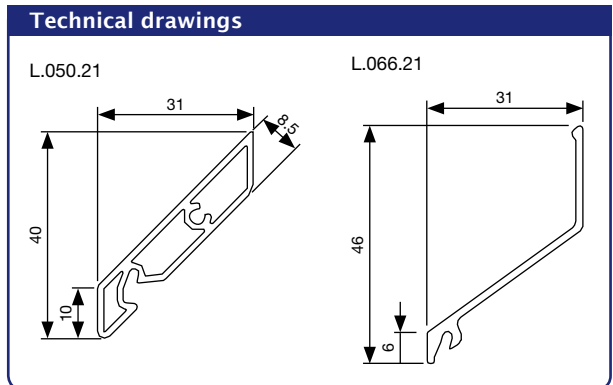
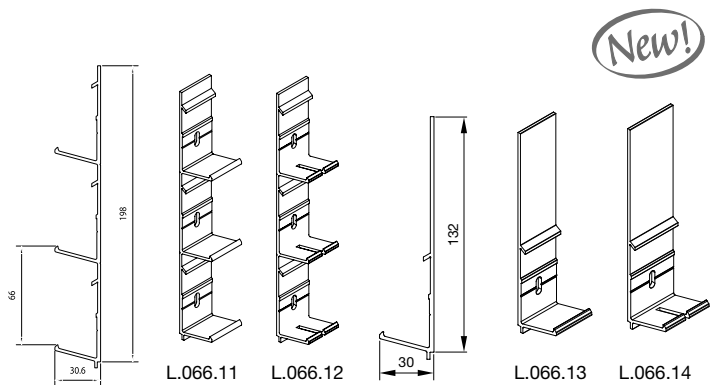
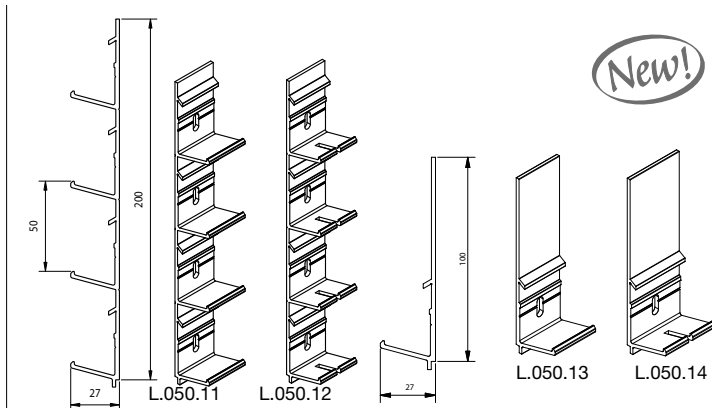
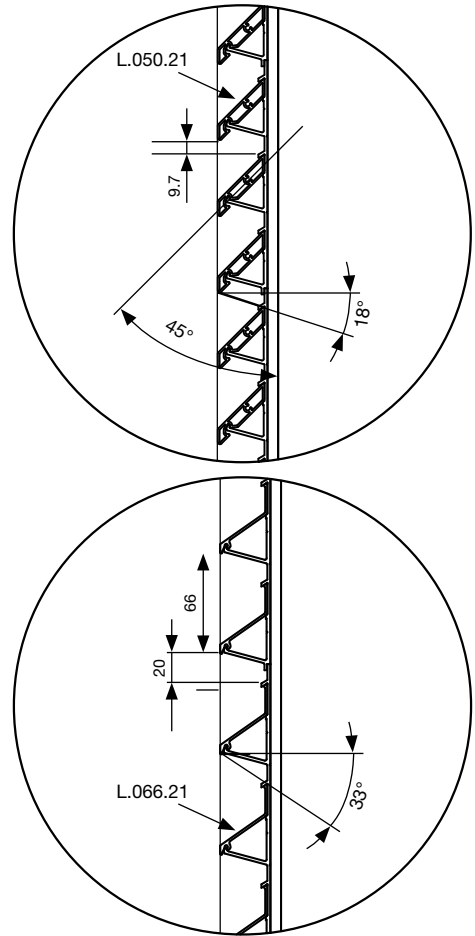

Technical data	
	<b>L.050.21</b>
Pitch	50 mm
Depth	31 mm
Height	40,5 mm
Visual free area*	80%
Physical free area*	53%
Max. unsupported span between two mullions**	800 mm
	<b>L.066.21</b>
Pitch	66 mm
Depth	33 mm
Height	46 mm
Visual free area*	92%
Physical free area*	50%
Max. unsupported span between two mullions**	1000 mm

\* Definition see p. 50  
\*\* At qb 800 Pa wind pressure

Sunclips® Evo blades composed of extruded aluminium profiles useable as solar shading, cladding or visual barrier. Sunclips® Evo blades are semi-open C-shaped profiles fitted with screw ducts with 96, 130 and 176 mm oversizing.

**Materials**

- Aluminium extrusion, alloy EN AW 6063 T66

**Finish**

- Anodised (20 micron)
- Polyester powder coating RAL or Syntha Pulvin® colours (60 - 80 µ/40 µ (UK))

**Mesh**

Fixed to rear of the support structure.

**Doors**

Single and double doors available with standard RENSON® hardware and rotating on pivot (see p. 71-72)

**Blade support**

- Single blade support: Type SE.082.11 (width: 28 mm)
- Double blade support for thermal expansion: SE.082.12 (width: 45 mm) (connecting piece for 2 blades)

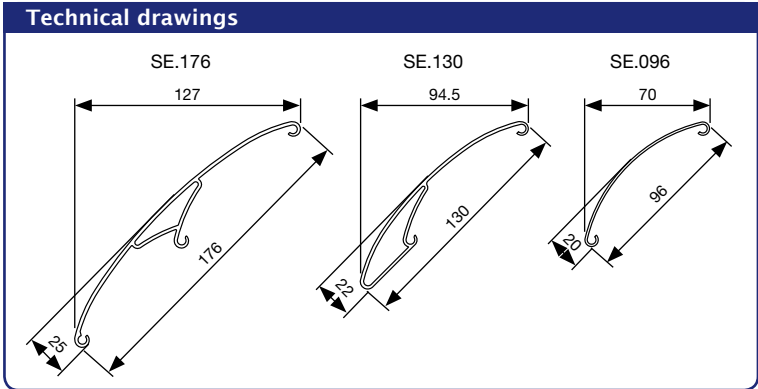
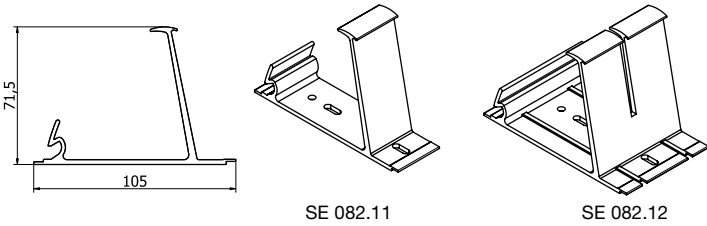

Technical data	
	<b>Sunclips® EVO</b>
Pitch	variable (min. 100mm)
Depth & height	Evo 96 = 70 mm Evo 130 = 94,5 mm Evo 176 = 127 mm
Physical free area* Evo 96	53%
K-Factor* Evo 96	6,23
Max. unsupported span between two mullions**	Evo 96 = 1200 mm Evo 130 = 1800 mm Evo 176 = 1800 mm
* Definition see p. 50	
** At qb 800 Pa wind pressure	

## Selection criteria

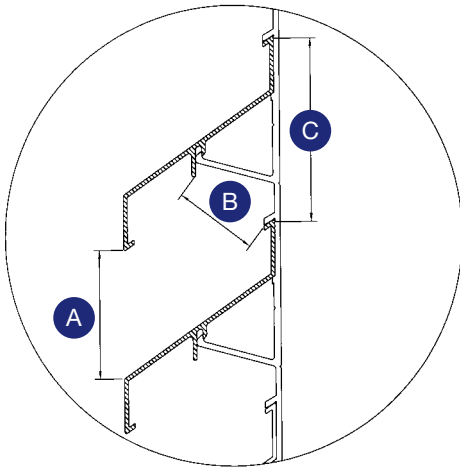

- A** Visual distance between 2 blades
- B** Narrowest opening between 2 blades
- C** The pitch of the blade

This chapter offers you assistance in selecting the ideal RENSON® louvre ventilation system. Some definitions well-known in the field of natural ventilation are explained.

If the CLS is only used for aesthetic reasons, the theoretical values calculated using the formulas below can still provide an added value.

### Definition 1: visual free area (\*)

The visual free area is determined by the ratio between the visual distance between two blades (A) and the pitch of the blade (C).

### Definition 2: physical free area (\*)

The physical free area is determined by the ratio between the narrowest opening between two blades (B) and the pitch of the blade (C).

(\*) Both definitions of the free area do not take into account the influence of top and bottom blades.

### Definition 3: K-Factor

The K-factor is a value describing the aerodynamic resistance to air flow. Contrary to the free area it describes the relationship between the air flow through the louvre and the pressure drop over it. For exact interpretation purposes, the calculation is explained step by step below.

To find the resistance to air flow due to the insertion of a louvre into an opening, a K-factor must be used. This factor is determined by trial and error. Where specific volumes or air speeds are required, one can better not use the free area to calculate the drop of pressure over or the size of the louvre.

RENSON® recommends the use of K-factors which are established by the actual testing of a louvre. Blades with the same

free area can have different K-factors. This is caused by small differences in the shape of the profiles (e.g. different blade gradient, different shape of the edges of the blades, etc.).

The free area must be used in cases where the open part of the CLS must be equal to a certain percentage of the floor surface.

Before one can determine the pressure drop one must determine the air speed using the following equation:

$$\text{Air speed} = \frac{\text{FLOW RATE}}{\text{SURFACE}} \quad (\text{a})$$

Flow rate = m<sup>3</sup>/s    the volume of air passing through the CLS  
 Surface area = m<sup>2</sup>    the size of the louvre (front view)  
 Air speed = m/s    the speed of the approaching air at the front of the CLS. (This is the result of a certain volume passing through the CLS.)

If two elements are known in this equation, one can calculate the third.

$$\text{Pressure drop} = K \times 0,6 \times \text{Air speed}^2 \quad (\text{b})$$

One can transpose the equations to determine dimensions, air speeds or pressure drop.

## Use of the K-Factor method

<p><b>METHOD 1: identify suitable louvre type for a certain opening size</b></p> <ol style="list-style-type: none"> <li>1. Determine the required air flow rate</li> <li>2. Determine the available opening (size of the louvre)</li> <li>3. Determine the maximum permitted pressure drop</li> <li>4. Choose the appropriate louvre type based on the K-Factor</li> </ol>	<p><b>METHOD 2: determine required louvre size when louvre type is already chosen</b></p> <ol style="list-style-type: none"> <li>1. Choose preferred louvre type</li> <li>2. Determine the air speed at the face of the louvre by means of the K-factor and the maximum pressure drop</li> <li>3. Determine the required air flow rate</li> <li>4. Determine the minimum louvre size</li> </ol>
--	---

### Example of method 1

Which type of louvre is suitable to achieve the desired ventilation volume of 55,000 m<sup>3</sup>/h with a maximum pressure drop of 25 Pa and an opening of 10 m<sup>2</sup>?

**Calculation:**

$$\text{Air speed} = 15,28 \text{ m}^3/\text{s} / 10 \text{ m}^2 \text{ (surface area)} = 1,53 \text{ m/s}$$

Calculation formula (a)  
 Flow rate = 55000 / 3600 = 15,28 m<sup>3</sup>/s  
 Size of the louvre = 10 m<sup>2</sup>

Calculation formula (b)  
 Pressure drop = 25 Pa  
 Air speed = 1,53 m/s

$$\text{K-Factor} = 25 / (0,6 \times 1,53^2) = 17.80$$

This is the maximum K-value to achieve the desired volume with a certain pressure drop and size. Blade types L.050, L.050HF, L.060AC, L.060HF, L.065, L.066, L.075, L.095 and L.120 can be recommended. The final choice depends on personal preference.

### Example of method 2

Blade type L.050.00 is preferred by the architect. What size is required to achieve a maximum pressure drop of 30 Pa for a given flow rate of 10,000 m<sup>3</sup>/h ?

**Calculation:**

Calculation formula (b)  
 K (L.050.00) = 12,57

$$\text{Air speed} = \sqrt{\frac{30}{0,6 \times 12,57}} = 1,99 \text{ m/s}$$

Calculation formula (a)  
 Flow rate = 10.000 / 3.600 = 2,78 m<sup>3</sup>/s

$$\text{Surface area} = \frac{2,78 \text{ m}^3/\text{s}}{1,99 \text{ m/s}} = 1,39 \text{ m}^2$$

This is the minimum surface area of louvre type L.050.00 needed to obtain a pressure drop of less than 30 Pa at a flow rate of 10,000 m<sup>3</sup>/h.

## Water penetration tests (or HEVAC tests) - principle

The RENSON® louvres were subjected to HEVAC testing in Great Britain by a body accredited world-wide.

A wall of 1 m<sup>2</sup>, possibly fitted with a stainless steel 304 mesh, was tested in torrential rain with a capacity of 75 litres/hour and a wind speed of 13 m/second. The HEVAC class table is drawn up depending on the results obtained, i.e. the quantity of water passing through the louvre.

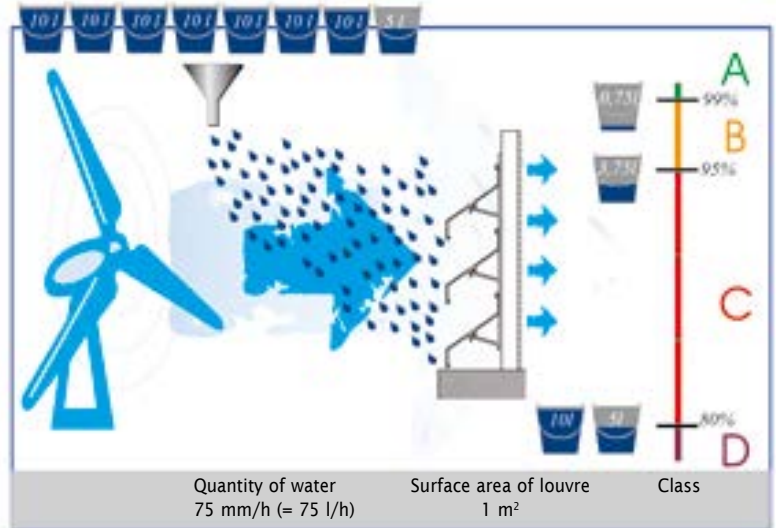

*Test of a standard CLS*

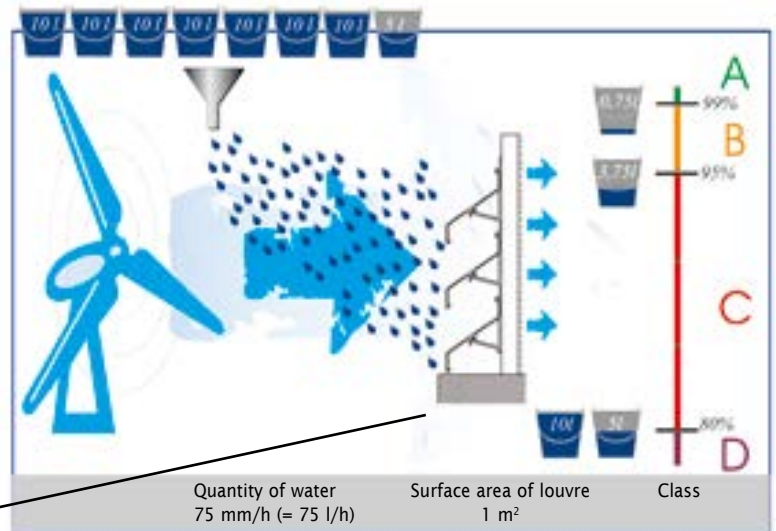
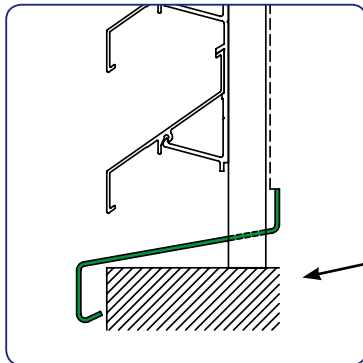

*Test of a CLS with mesh and sill*

## Water penetration tests (or HEVAC tests) - principle

	HEVAC Class	% watertightness
Very good rain protection	A	100 - 99
Good rain protection	B	98,9 - 95
Average rain protection	C	94,9 - 80
Low rain protection	D	< 80

Type	Air speed (m/s)	Standaard uitvoering Class	With sill Class
<i>With mesh 2,3 x 2,3 mm</i>			
L.033.01	0,0	B	B
	0,5	B	B
	1,0	C	B
	1,5	D	C
L.033.08	0,0	-	A
	0,5	-	A
	1,0	-	C
	1,5	-	D
Extreme L.050W	3,0	A2	A2
L.050.00	0,0	C	B
	0,5	C	B
	1,0	D	C
	1,5	D	C
L.066.01	0,0	C	B
	0,5	C	B
	1,0	C	C
	1,5	C	C
	2,0	D	C
	2,5	D	C
L.066V	0,0	-	A
	0,5	-	A
	1,0	-	A
	1,5	-	B
	2,0	-	D
L.066V (vertical blades)	0,0	-	A
	0,5	-	A
	1,0	-	A
	1,5	-	A
	2,0	-	C
L.095.01	0,0	C	B
	0,5	D	C
	1,0	D	C
	1,5	D	C
	2,0	D	D
L.150ACS	0,0	-	A
	0,5	-	B
	1,0	-	C
	1,5	-	D
	2,0	-	D
<i>With mesh 6 x 6 mm</i>			
L.033V	0,0	A	A
	0,5	B	A
	1,0	C	B
	1,5	C	C
	2,0	D	D
L.050.00	0,0	C	C
	0,5	C	C
	1,0	D	C
	1,5	D	C
	2,0	D	C
	2,5	D	D
L.095.01	0,0	D	C
	0,5	D	C
	1,0	D	C
	1,5	D	D
Type	Air speed (m/s)	Without mesh	With mesh L.075.32
L.075.01	0,0	C	A
	0,5	C	B
	1,0	C	C
	1,5	D	D
Type	Air speed (m/s)	Without mesh L.075.33	With mesh L.075.34
L.075.01	0,0	C	B
	0,5	C	B
	1,0	C	C
	1,5	C	C
	2,0	D	D

## Overview table

BLADE TYPE	Pitch (mm)	Blade height (mm)	Materials	Mesh	Curved	Door	Mitred corner
L.033.01	33,3	37,5	Alu	Behind	yes	yes	yes
L.033.08	33,3	42,3	Alu	Behind	no	yes	yes
L.033HF	33,3	37,5	Alu	Behind	yes	yes	yes
L.033V	33,3	37,6	Alu	Behind	no	yes	yes
L.033CL	33,3	38,2	Alu	-	no	yes	yes
L.033IM1	33,3	38,2	Alu	Integrated	no	yes	yes
L.050.00	50	56	Alu	Behind	yes	yes	yes
L.050.01	50	56	Alu	L.050.33 between	no	yes	yes
L.050.01	50	56	Alu	L.050.34 between	no	yes	yes
L.050.21	50	40	Alu	Behind	no	yes	yes
L.050.25	50	60	Alu	Behind	no	yes	yes
L.050HF	50	50	Alu	Behind	yes	yes	yes
L.050CL	50	60	Alu	-	no	yes	yes
L.050W	50	89,6	Alu	Behind	no	no	yes
L.050WS	50	50,5	Alu	Behind	no	yes	yes
L.060AC	60	69	Alu	Behind	no	yes	yes
L.060HF	60	60	Alu	Behind	no	yes	yes
L.065AL	65	70	Alu	Behind	no	yes	yes
L.065GL	65	70	galv. steel	Behind	no	no	no
L.065/STS	65	70	stainless steel	Behind	no	no	no
L.066.01	66	76,5	Alu	Behind	no	yes	yes
L.066.06	66	73	Alu	Behind	no	yes	yes
L.066.21	66	46	Alu	Behind	no	yes	yes
L.066P	66	15	Alu	Behind	no	yes	yes
L.066S	66	76,5	Alu	Behind	no	yes	yes
L.066V	66	74	Alu	Behind	no	yes	yes
L.066CL	66	76,5	Alu	-	no	yes	yes
L.066IM1	66	76,5	Alu	Behind	no	yes	yes
L.075.01	75	89,2	Alu	Behind	no	yes	yes
L.075.01	75	89,2	Alu	L.075.32 between	no	yes	yes
L.075.01	75	89,2	Alu	L.075.33 between	no	yes	yes
L.075.01	75	89,2	Alu	L.075.34 between	no	yes	yes
L.075S	75	89,5	Alu	Behind	no	yes	yes
L.095.01	95	102,1	Alu	Behind	no	yes	yes
L.095.01	95	102,1	Alu	L.095.33 between	no	yes	yes
L.095S	95	101,1	Alu	Behind	no	yes	yes
L.120	120	120	Alu	Behind	no	yes	yes
L.150DAC	150	170	Alu	Behind	no	yes	yes
L.170DAC	170	170	Alu	Behind	no	yes	yes
L.150ACS	150	239	Alu	Behind	no	not recommended	yes
L.170ACS	170	239	Alu	Behind	no	not recommended	yes
L.150ACL	150	328	Alu	Behind	no	not recommended	yes
L.170ACL	170	328	Alu	Behind	no	not recommended	yes

The friction coefficient (determined using wind tunnel tests) indicates how the wind affects the blade.

$C_{fy}$  = coefficient used to determine the horizontal load (drag) on a blade

$C_{fz}$  = coefficient used to determine the vertical load (lift) on a blade

Visual free area (%)	Physical free area (%)	Friction coefficient $C_{fy}$	Friction coefficient $C_{fz}$	K-Factor				BLADE TYPE
				Supply without mesh	Supply with mesh	Exhaust without mesh	Exhaust with mesh	
59	44,7	1,34	0,44	22,68	23,56	25,25	25,51	L.033.01
56	26	1,3	0,5	-	123,46	-	118,15	L.033.08
59	50	1,34	0,44	22,46	22,89	26,03	26,03	L.033HF
59	43	1,4	-0,2	61,04	66,1	61,04	66,1	L.033V
59	-	1,34	0,44	-	-	-	-	L.033CL
59	24	1,34	0,44	-	34,7	-	31,0	L.033IM1
70	49	1,28	0,74	12,57	13,42	8,91	9,34	L.050.00
70	42	1,28	0,74	-	14,79	-	12,94	L.050.01
70	30,8	1,28	0,74	-	-	-	-	L.050.01
80	53	1,17	0,94	-	-	-	-	L.050.21
50	32,5	1,34	0,44	15,69	-	16,33	-	L.050.25
70	60	1,21	0,85	8,75	9,41	8,86	9,47	L.050HF
70	-	1,3	0,74	-	-	-	-	L.050CL
70	57	1,3	0,95	-	10,47	-	-	L.050W
70	59	1,28	0,74	6,09	-	6,85	-	L.050WS
75	34	1,36	1,09	9,22	-	13,29	-	L.060AC
90	76	1,23	1,32	5,03	5,59	4,96	5,62	L.060HF
70	56	1,26	0,68	13,32	13,92	17,08	17,22	L.065AL
70	56	1,26	0,68	13,32	13,92	17,08	17,22	L.065GL
70	56	1,26	0,68	13,32	13,92	17,08	17,22	L.065/STS
70	49,2	1,27	0,71	13,62	14,24	14,91	14,91	L.066.01
50	37,8	1,34	0,44	29,11	-	29,3	-	L.066.06
92	50	1,5	0,76	-	-	-	-	L.066.21
77	77	1,02	0,42	-	-	-	-	L.066P
70	49,2	1,28	0,74	13,62	-	14,62	-	L.066S
70	40,6	1,6	1,1	-	66,10	-	79,72	L.066V
70	-	1,3	0,71	-	-	-	-	L.066CL
70	32	1,3	0,71	-	17,58	-	19,03	L.066IM1
94	43	1,22	0,71	16,52	-	17,65	-	L.075.01
94	23	1,22	0,71	-	41,62	-	35,43	L.075.01
94	43	1,22	0,71	-	19,75	-	19,93	L.075.01
94	30	1,22	0,71	-	30,52	-	32,65	L.075.01
94	46,5	1,22	0,71	16,52	-	17,65	-	L.075S
86	55,5	1,33	0,89	11,41	-	11,65	-	L.095.01
86	49	1,33	0,89	-	15,38	-	14,79	L.095.01
86	55	1,33	0,89	9,7	-	9,4	-	L.095S
66	60	1,21	0,85	13,82	-	14,68	-	L.120
54	34,3	1,36	1,09	47,70	-	42,47	-	L.150DAC
59	37	1,36	1,09	41,08	-	37,58	-	L.170DAC
54	34,3	1,36	1,09	27,4	-	27,1	-	L.150ACS
59	37	1,36	1,09	25,4	-	25,1	-	L.170ACS
54	34,3	1,36	1,09	37,3	-	41,9	-	L.150ACL
59	37	1,36	1,09	28,58	-	30,88	-	L.170ACL

## Supporting structures



A system consisting of extruded aluminium mullions on which the blade supports and blades are fixed.

The fully homogenous structure is designed according to CEN/TC 250/SC9 Eurocode - 9/BS8118 for the structural use of aluminium. The fitting of the mullions is determined in accordance with CEN/TC 250/SC1 Eurocode 1/BS, section 3 and good craftsmanship.

The blades click tight onto the blade supports. The choice of the pitch and other aspects is based on the data described on page 29. The various options of doors, mitred corners and acoustic elements can be selected and integrated in the design.

The complete supporting structure is prepared for the fastening of the blade supports. Fastening can already fully take place at the factory or be partly left for assembly on the site. With the last option one has the flexibility to fasten the last blade supports on site and cut the mullions to size for a perfect installation.



Extruded aluminium profile for continuous support, directly assembled on an existing wall or steel supporting structure.

#### Materials

- Aluminium extrusion, alloy EN AW 6063 T66

#### Finish

- Anodised (20 micron)
- Polyester powder coating RAL or Syntha Pulvin® colours (60 - 80 µ/40 µ (UK))

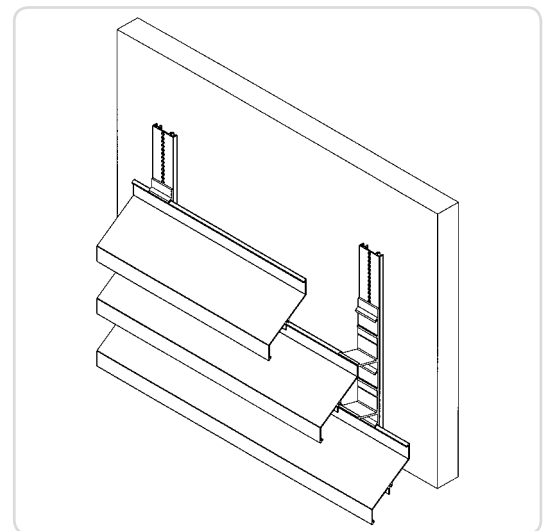
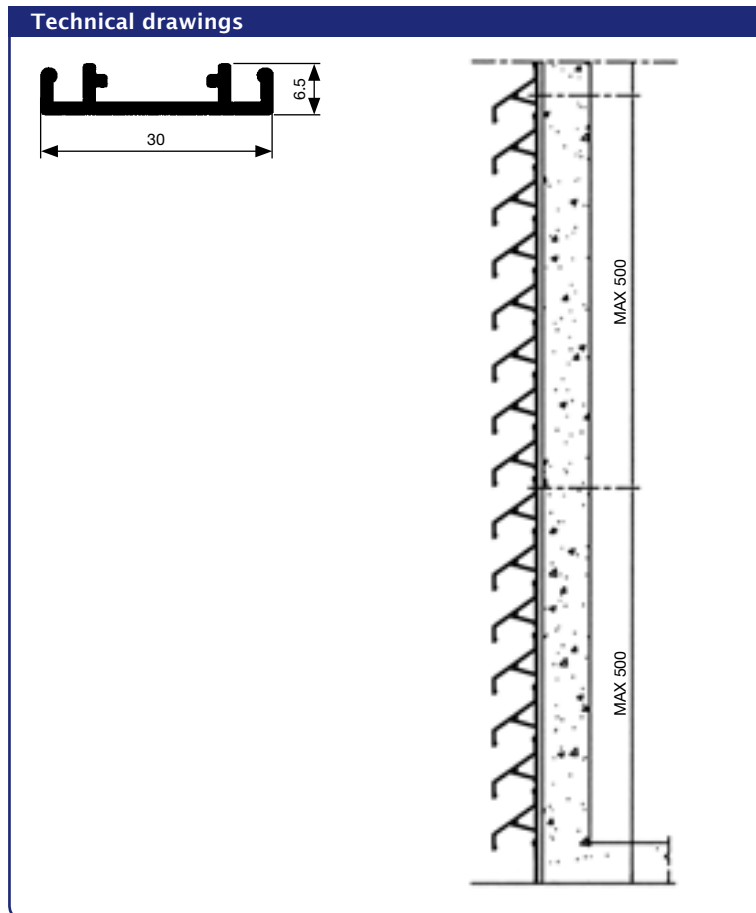

#### Technical data

	<b>LD.0065</b>
Profile depth	6,5 mm
Profile width	30 mm
Moment of inertia	260 mm <sup>4</sup>
Flexural modulus	59 mm <sup>3</sup>

*Recommended for fastening to fixed structures.*

## LD.0195 < Supporting structures



Extruded aluminium profile for limited vertical span, directly assembled on an existing wall or steel supporting structure. Type LD.0195 is used to a maximum span of  $\pm 600$  mm.\*

### Materials

- Aluminium extrusion, alloy EN AW 6063 T66

### Finish

- Anodised (20 micron)
- Polyester powder coating RAL or Syntha Pulvin® colours (60 - 80  $\mu$ /40  $\mu$  (UK))

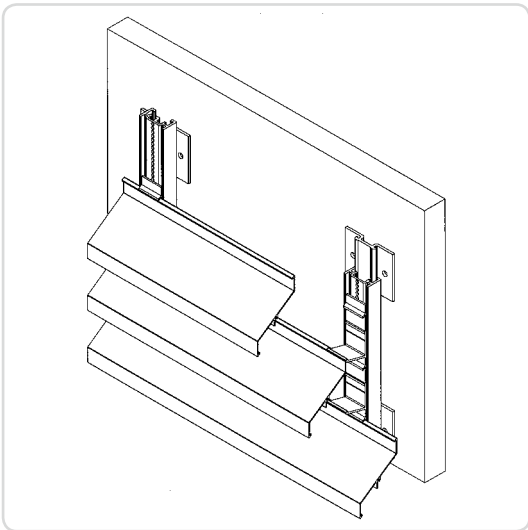

### Technical drawings

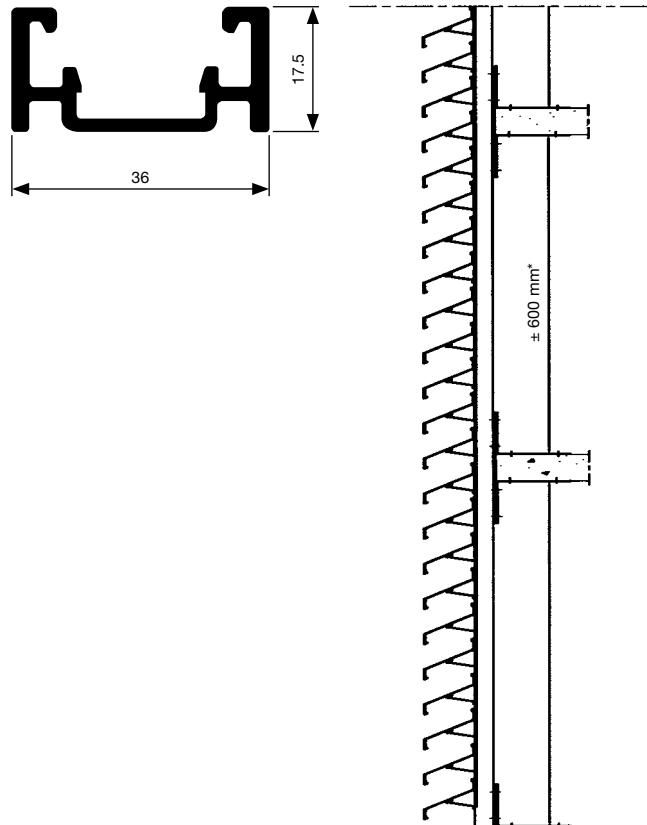

### Technical data

	LD.0195
Profile depth	17,50 mm
Profile width	36 mm
Moment of inertia	6.560 mm <sup>4</sup>
Max. height span	$\pm 600$ mm
Flexural modulus	607 mm <sup>3</sup>

(\* Max. span is calculated for a wind pressure of 800Pa and depends on applicable laws and the blade type)

Extruded aluminium profile suitable for constructions and sideways fixation (see illustration). Used up to a maximum span of  $\pm 1500$  mm\*.

#### Materials

- Aluminium extrusion, alloy EN AW 6063 T66

#### Finish

- Anodised (20 micron)
- Polyester powder coating RAL or Syntha Pulvin® colours (60 - 80  $\mu$ /40  $\mu$  (UK))

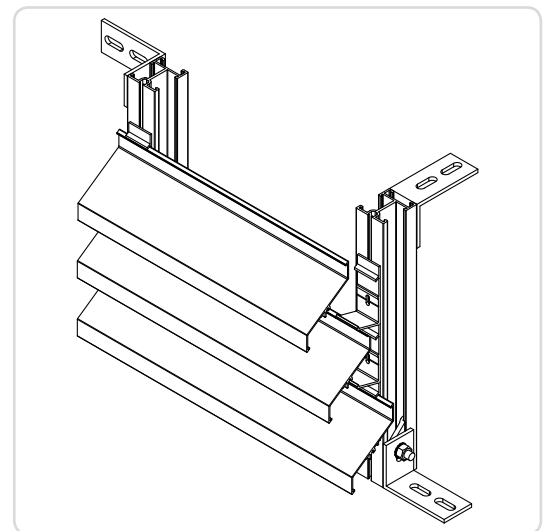
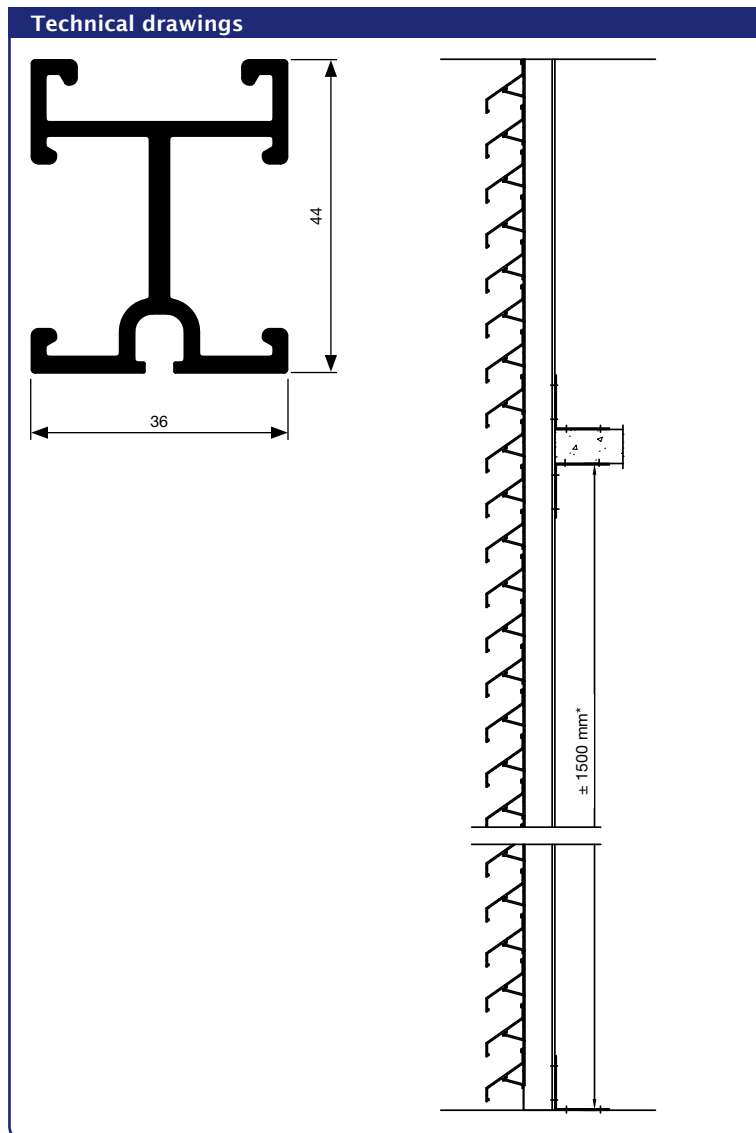

Technical data	
	<b>LD.0440</b>
Profile depth	44 mm
Profile width	36 mm
Moment of inertia	83.228 mm <sup>4</sup>
Max. height span	3.622 mm <sup>3</sup>
Max. height span	$\pm 1500$ mm

(\* Max. span is calculated for a wind pressure of 800Pa and depends on applicable laws and the blade type)

## LD.0460 < Supporting structures

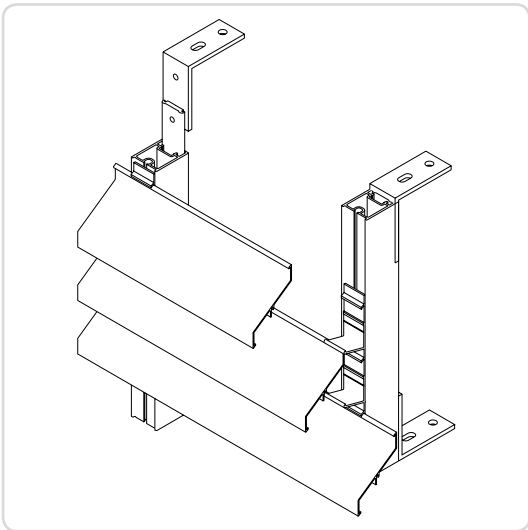

Extruded aluminium profile for medium vertical span used up to a maximum span of  $\pm 1,500$  mm.\*

### Materials

- Aluminium extrusion, alloy EN AW 6063 T66

### Finish

- Anodised (20 micron)
- Polyester powder coating RAL or Syntha Pulvin® colours (60 - 80  $\mu$ /40  $\mu$  (UK))

### Technical drawings

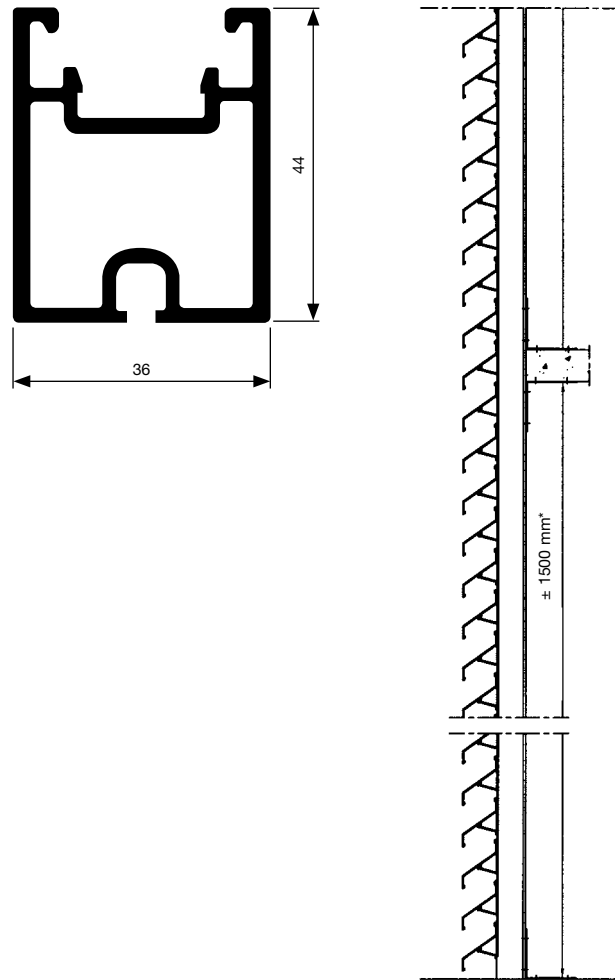

### Technical data

	LD.0460
Profile depth	44 mm
Profile width	36 mm
Moment of inertia	81.900 mm <sup>4</sup>
Flexural modulus	3426 mm <sup>3</sup>
Max. height span	$\pm 1500$ mm

(\* Max. span is calculated for a wind pressure of 800Pa and depends on applicable laws and the blade type)

The LD.0995 type can be used for large vertical spans up to  $\pm 2,800$  mm. It is attached to the structure using the mechanical fasteners supplied.

#### Materials

- Aluminium extrusion, alloy EN AW 6063 T66

#### Finish

- Anodised (20 micron)
- Polyester powder coating RAL or Syntha Pulvin® colours (60 - 80  $\mu$ /40  $\mu$  (UK))

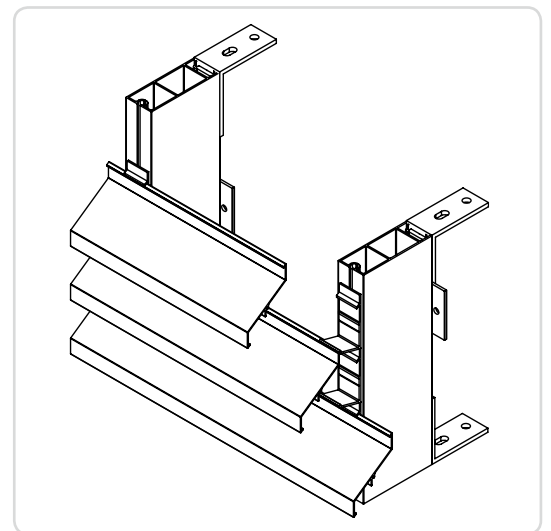
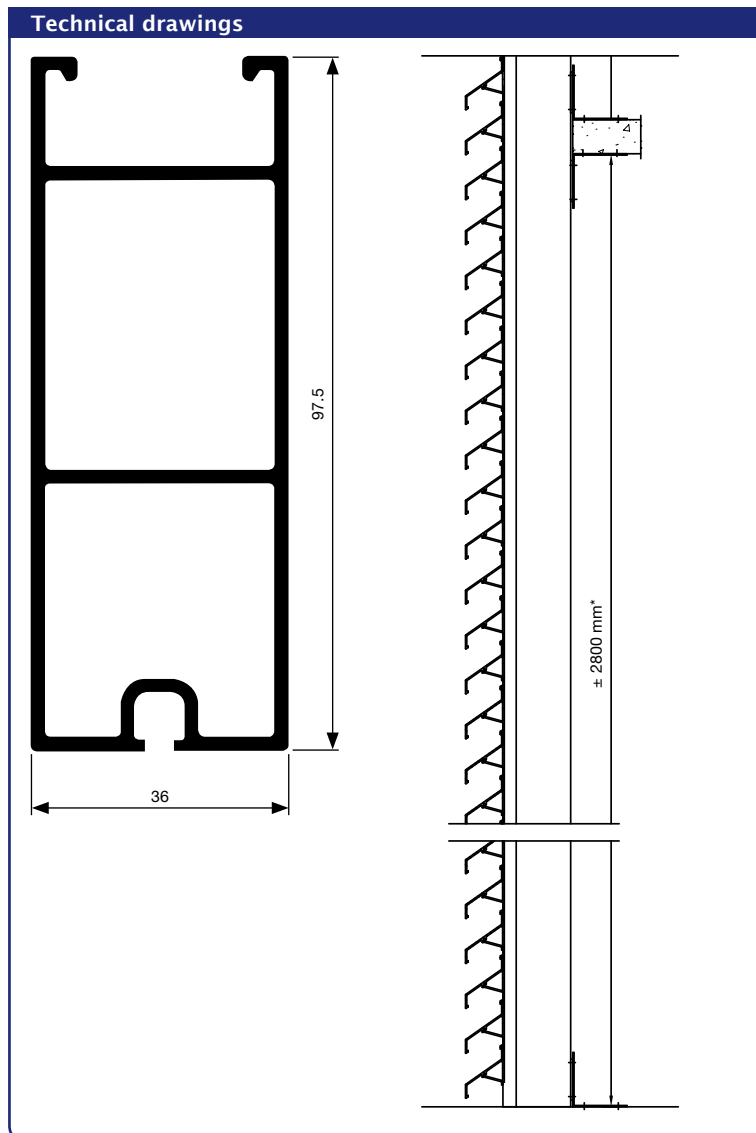

Technical data	
	<b>LD.0995</b>
Profile depth	97,50 mm
Profile width	36 mm
Moment of inertia	481.949 mm <sup>4</sup>
Flexural modulus	11.197 mm <sup>3</sup>
Max. height span	$\pm 2.800$ mm

(\* Max. span is calculated for a wind pressure of 800Pa and depends on applicable laws and the blade type)

## LD.1250 < Supporting structures

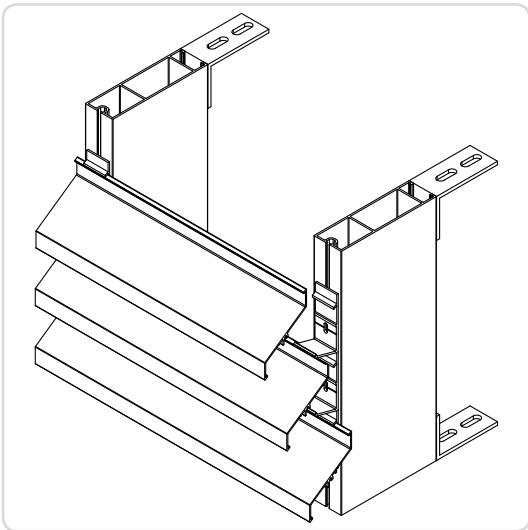

Extruded aluminium profile suitable for very large spans. Used up to a maximum span of  $\pm 3600\text{mm}^*$ .

### Materials

- Aluminium extrusion, alloy EN AW 6063 T66

### Finish

- Anodised (20 micron)
- Polyester powder coating RAL or Syntha Pulvin® colours (60 - 80  $\mu$ /40  $\mu$  (UK))

### Technical drawings

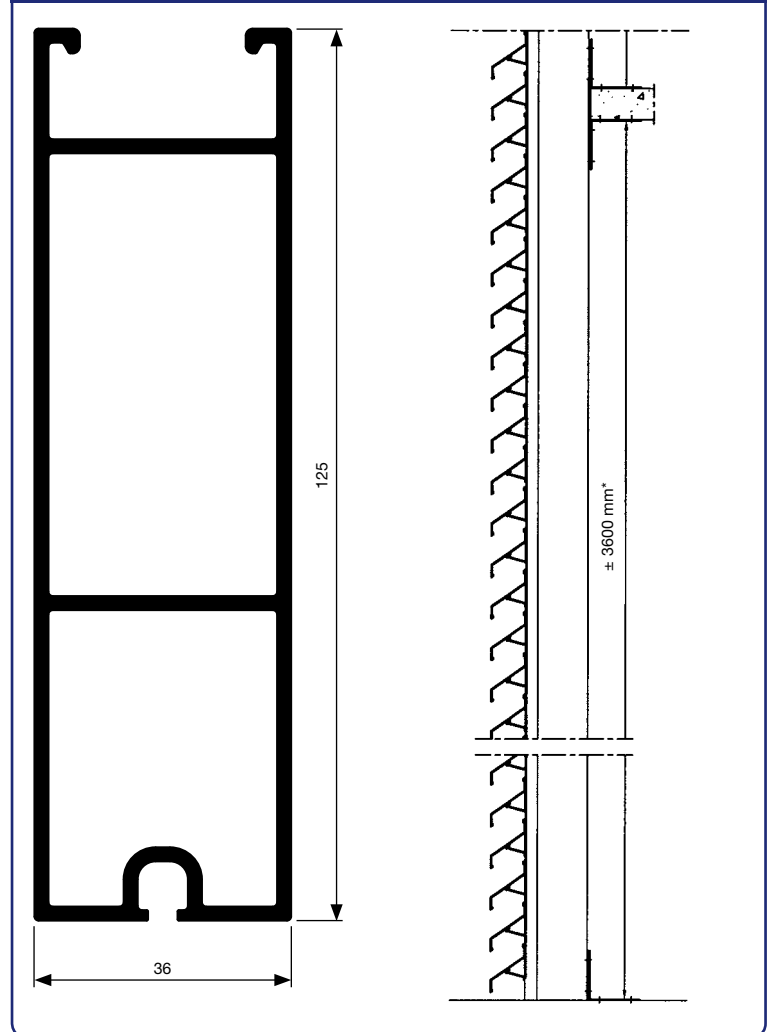

### Technical data

	LD.1250
Profile depth	125mm
Profile width	36mm
Moment of inertia	1.219.444mm <sup>4</sup>
Flexural modulus	18.531mm <sup>3</sup>
Max. height span	$\pm 3600\text{mm}$

(\* Max. span is calculated for a wind pressure of 800Pa and depends on applicable laws and the blade type)

# Sunclips® supporting structures > SD.014 / SD.054 / SD.100

Extruded aluminium profiles, always to be used in combination with adapter profile LD.0108 (depth 14, 54 and 100 mm) as supporting structure for aesthetic application. Also for use in combination with Linius® blades as horizontal sun blind. For more info please see our RENSON® Sunclips® brochure.

## Materials

- Aluminium extrusion, alloy EN AW 6063 T66

## Finish

- Anodised (20 micron)
- Polyester powder coating RAL or Syntha Pulvin® colours (60 - 80 µ/40 µ (UK))

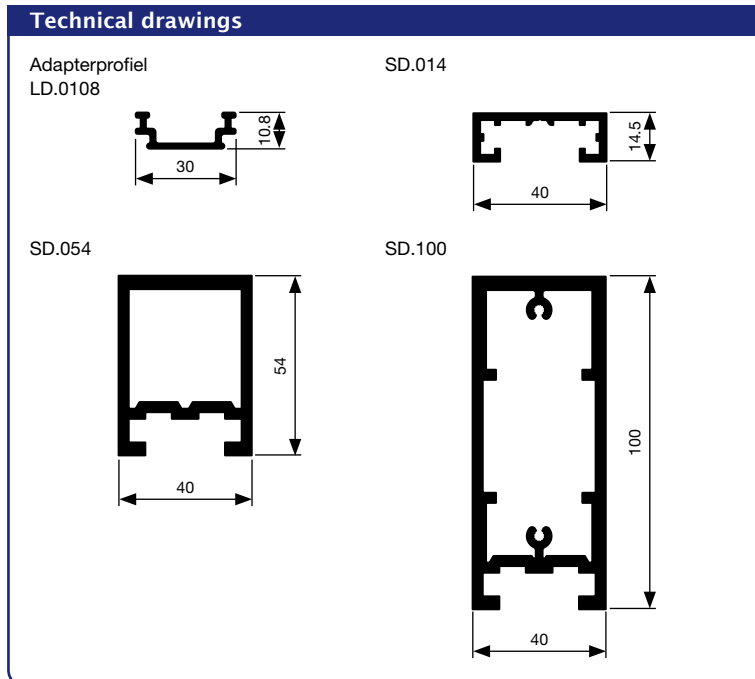

Technical data		SD
Profile depth	SD.014	14,5 mm
	SD.054	54 mm
	SD.100	100 mm
Profile width	SD.014/54/100	40 mm
Moment of inertia	SD.014	4.506 mm <sup>4</sup>
	SD.054	208.600 mm <sup>4</sup>
	SD.100	1.248.321 mm <sup>4</sup>
Flexural modulus	SD.014	495 mm <sup>3</sup>
	SD.054	7.371 mm <sup>3</sup>
	SD.100	24.381 mm <sup>3</sup>
Max. height span	SD.014	+/- 600 mm
	SD.054	+/- 2000 mm
	SD.100	+/- 3600 mm

(\* Max. span is calculated for a wind pressure of 800Pa and depends on applicable laws and the blade type)

# System depth

- L.033.01 / L.033.08 / L.033HF / L.033CL/L.033IM1
- L.033V
- L.050.00 / L.050.25 / L.050HF / L.050S / L.050CL
- L.050.21
- L.050W
- L.050WS
- L.060HF
- L.060AC
- L.065AL / L.065AL.02 / L.065GL / L.065STS
- L.066.01 / L.066S / L.066CL / L.066IM1
- L.066.06 / L. 66.21
- L.066P
- L.066V
- L.075.01
- L.075S
- L.095.01 / L.095S
- L.120
- L.150DAC / L.170DAC
- L.150ACS.01 / L.170ACS
- L.150ACL.01 / L.170ACL
- SE.096.01
- SE.130.01
- SE.176.01

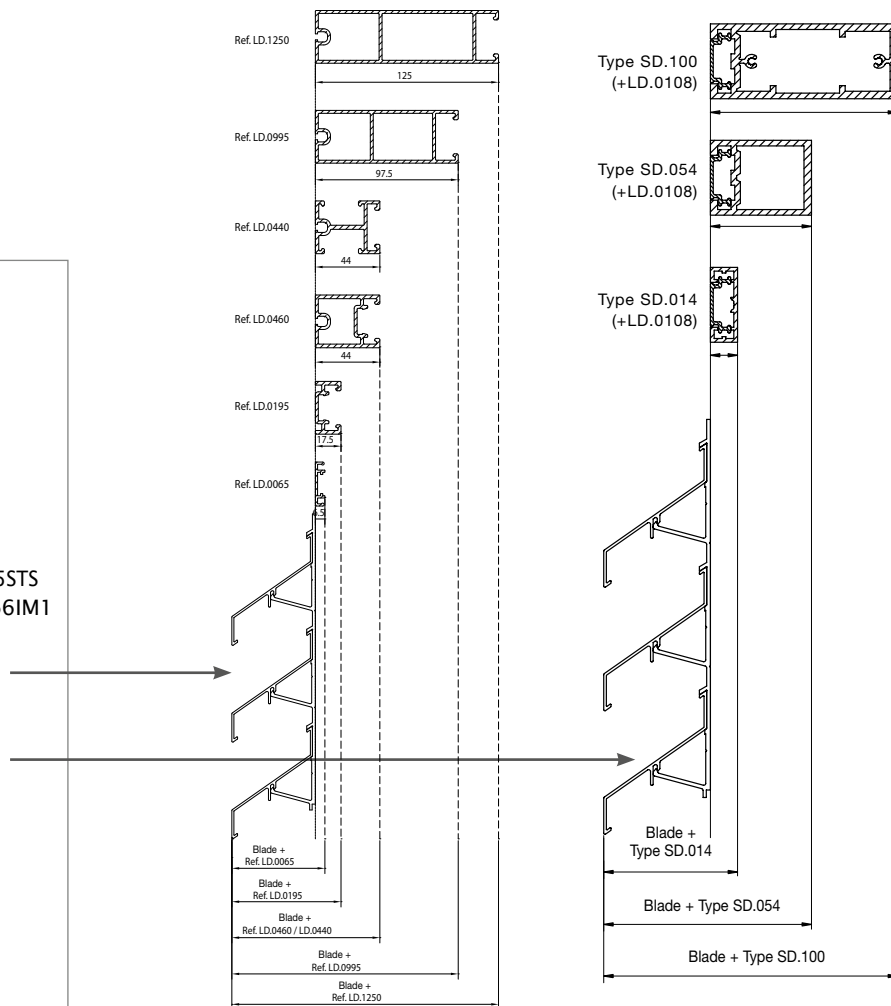

Total depth of a continuous louvre system (in mm):

	LD.0065	LD.0195	LD.0440	LD.0460	LD.0995	LD.1250	SD.014	SD.054	SD.100
L.033.01 / L.033.08 / L.033HF / L.033CL/L.033IM1	29	40	66,5	66,5	120	147,5	37	76,5	122,5
L.033V	48,1	59,1	85,6	85,6	139,1	166,6	56,1	95,6	141,6
L.050.00 / L.050.25 / L.050HF / L.050S / L.050CL	49,5	60,5	87	87	140,5	168	57,5	97	143
L.050.21	39,5	50,5	77	77	130,5	158	47,5	87	133
L.050W	139	150	177	177	230	258	147	187	233
L.050WS	59	70	96,5	96,5	150	177,5	66,5	106,5	152,5
L.060HF	87	98	124	124	178	205	95	134	180
L.060AC	83	94	120	120	174	201	91	130	176
L.065AL / L.065AL.02 / L.065GL / L.065STS	58,5	69,5	96	96	149,5	177	66,5	106	152
L.066.01 / L.066S / L.066CL / L.066IM1	63,5	74,5	101	101	154,5	182	71,5	111	157
L.066.06 / L. 66.21	39,5	50,5	77	77	130,5	158	47,5	87	133
L.066P	61,5	72,5	99	99	152,5	180	69,5	109	155
L.066V	70	81	107,5	107,5	161	188,5	78	117,5	163,5
L.075.01	63,5	74,5	100	101	154,5	182	71,5	111	157
L.075S	66	77	103,5	103,5	157	184,5	74	113,5	159,5
L.095.01 / L.095S	86	97	123,5	123,5	177	204,5	94	133,5	179,5
L.120	99	110	137	137	190	218	107	147	193
L.150DAC / L.170DAC	76,5	87,5	114	114	167,5	195	84,5	124	170
L.150ACS.01 / L.170ACS	176,5	187,5	214	214	267,5	295	184,5	224	270
L.150ACL.01 / L.170ACL	251,5	262,5	289	289	342,5	370	259,5	299	345
SE.096.01	81,8	92,8	119,3	119,3	172,8	200,3	89,8	126,3	175,3
SE.130.01	106,2	117,2	143,7	143,7	197,2	224,7	114,2	153,7	199,7
SE.176.01	138,2	149,2	175,7	175,7	229	256,7	146,2	185,7	231,7

# Fixing brackets

The Linius® mullions are fixed to an existing structure by means of specific brackets. Using brackets type LZ.4206, LZ.4209, LZ.4210 and LZ.4211 of the standard RENSON® product range, assembly of the mullions is easy in most situations.

The corners LZ.4203 and LZ.4209 are assembled on the rear of the mullions by means of clamping pieces LZ.4202 or LZ.4211. These parts have a thread or press bolt, which allows them to be fixed at any height to the support structure.

The LZ.4206 bracket slides into the rear of the supporting sections and can move freely in these profiles. A fastening point with this bracket guarantees horizontal stability but allows vertical movement due to thermal expansion. Mounting bracket LZ.4210 is used for wall mounting or ground mounting.

The type of bracket and the amount needed depends on the properties of each type of mullion.



## Fixing brackets LZ.4202 and LZ.4211

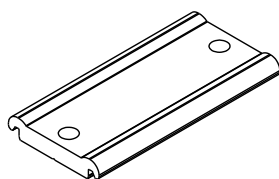
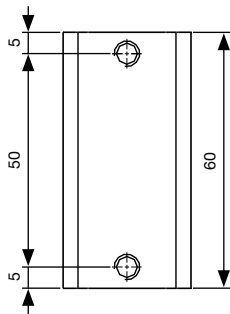
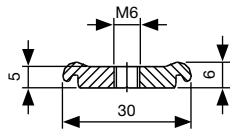

Type LZ.4202

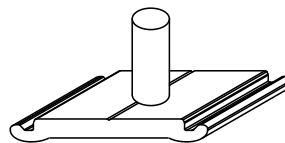
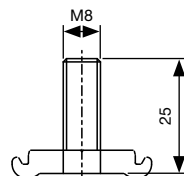
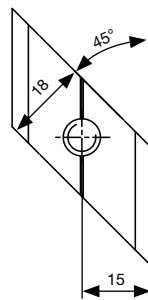

Type LZ.4211

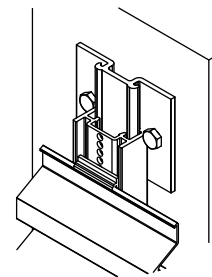
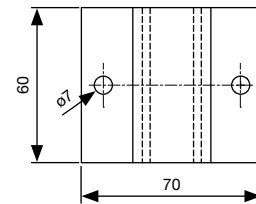
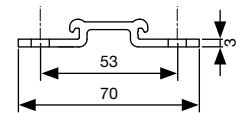

Type LZ.4206

# Fixing elements

## U-shape mounting bracket LZ.4210

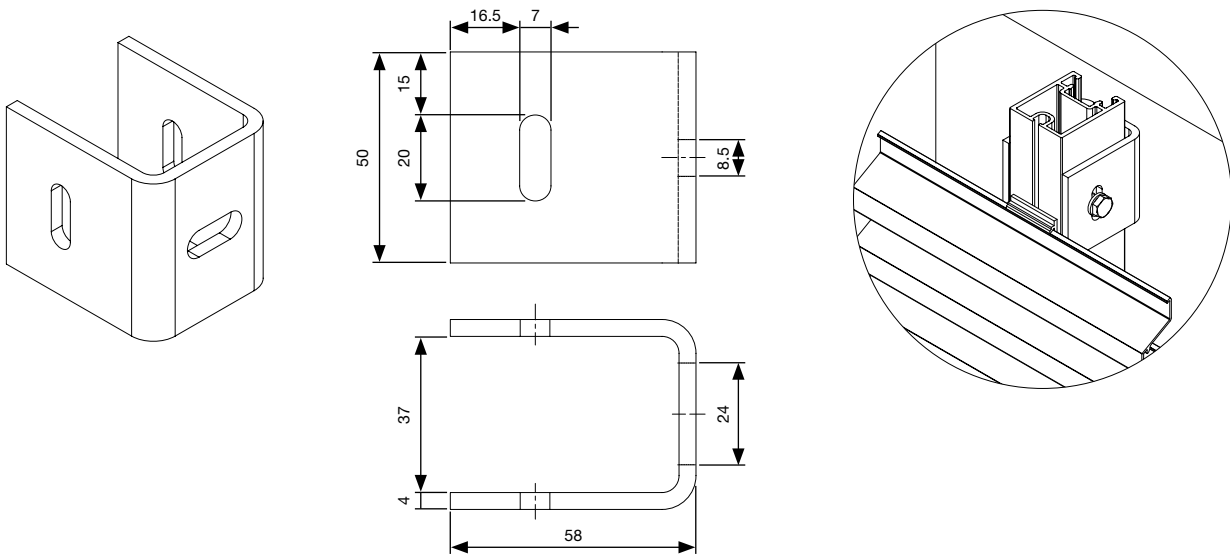

## Angle bracket LZ.4203 and LZ.4209

Where necessary, project specific brackets can be designed and provided by a RENSON® approved manufacturer/installer.

### Type LZ.4203

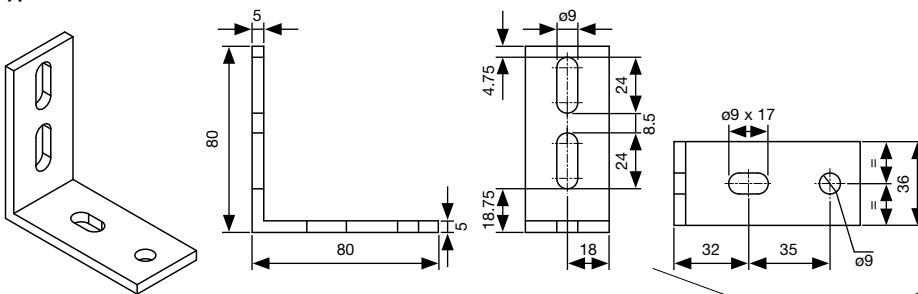

### Type LZ.4209

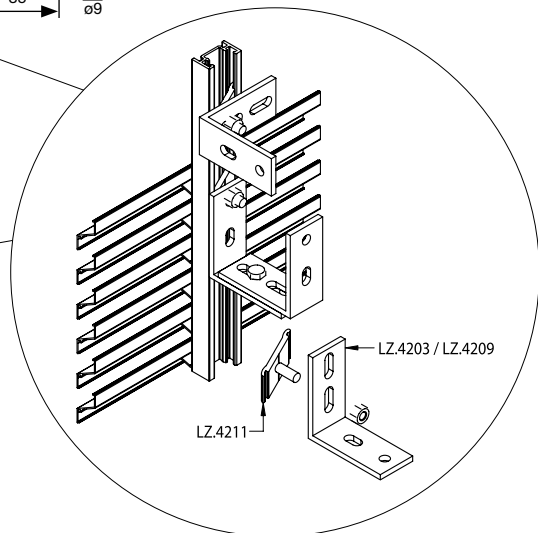
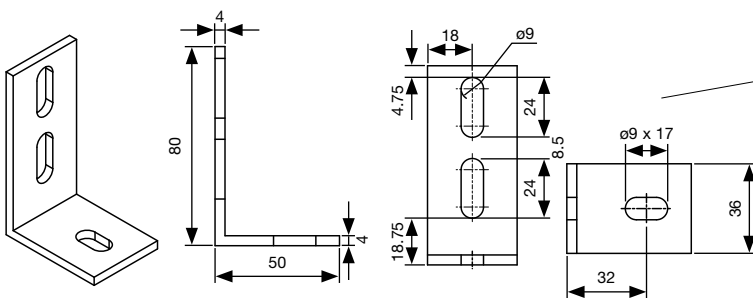

## A. Mesh

RENSON® offers various types of mesh to prevent the entry of insects, birds or vermin behind the continuous louver system.

### 1. The mesh can be riveted to the rear of the CLS by means of a flat profile.

Various types of stainless steel mesh of different sizes are available on rolls:

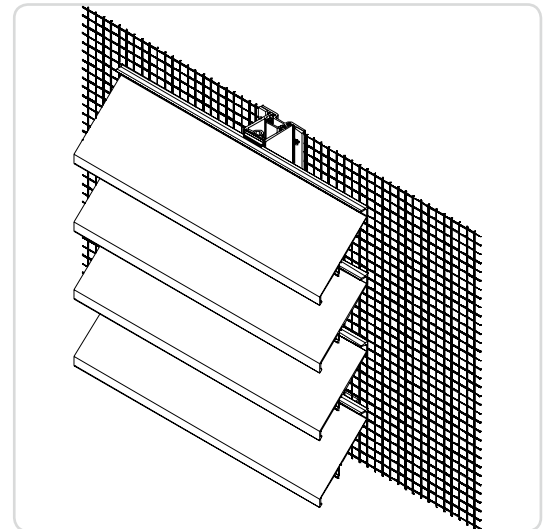
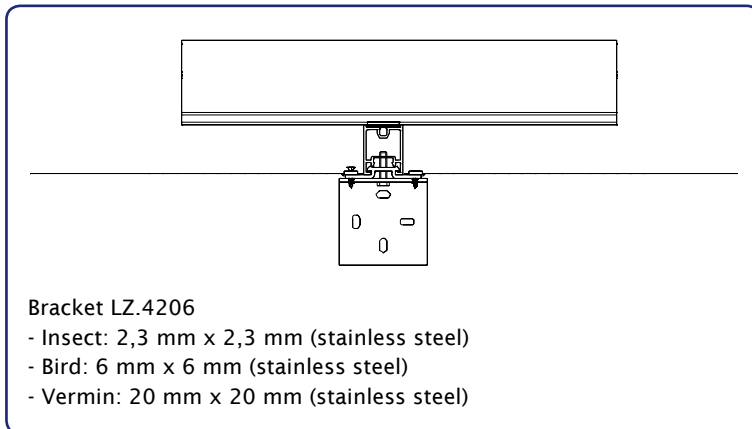

### 2. The mesh can be clipped between two blades. This is possible with blade type L.075, L.050, L.095

For blade type L.050.01, there are 3 types of meshes:

- Dense sheet (BOP) L.050.31
- Insect mesh L.050.34
  - Physical free area = 30,8%
- Bird mesh L.050.33
  - K-Factor = 14,79
  - Physical free area = 42%

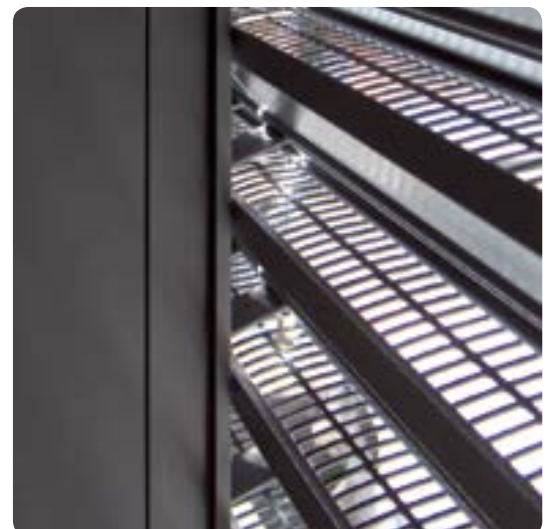
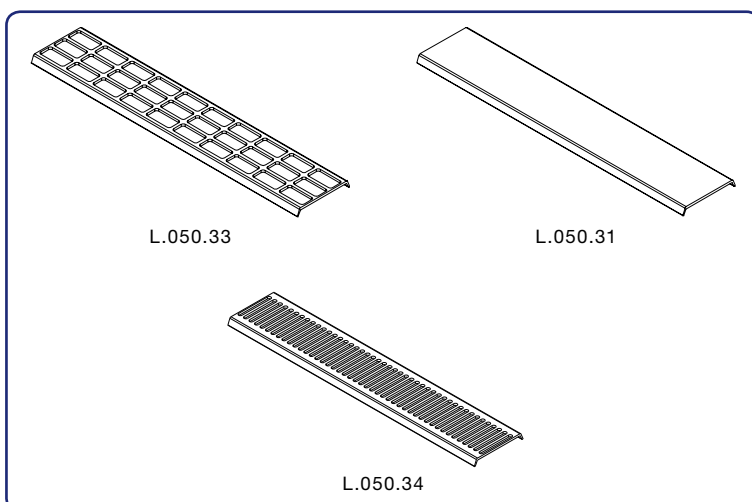

# Accessories



**For blade type L.075.01, there are 4 types of meshes:**

- Dense sheet (BOP) L.075.31
- Insect mesh L.075.32
  - K-Factor, supply = 41,62
  - Physical free area = 23%
- Bird mesh L.075.33
  - K-Factor, supply = 19,75
  - Physical free area = 43%
- Insect mesh L.075.34
  - K-Factor, supply = 30,52
  - Physical free area = 30%

Material: hard PVC, colour: black

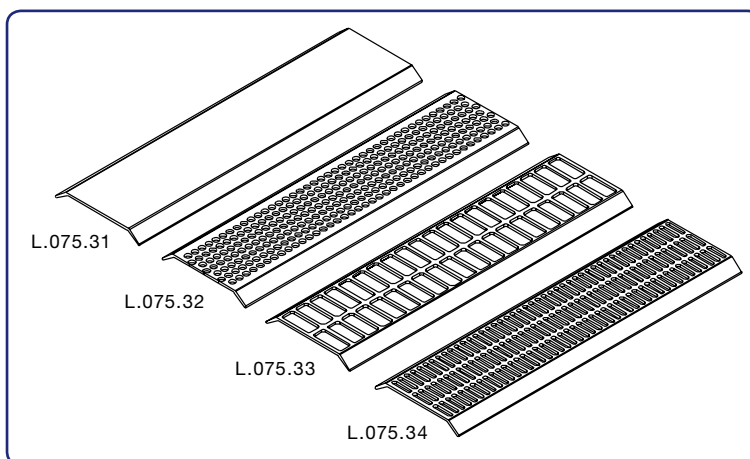

**For blade type L.095.01, there are 2 types of meshes:**

- Dense sheet (BOP) L.095.31
- Bird mesh L.095.33
  - K-Factor = 15,38
  - Physical free area = 42%

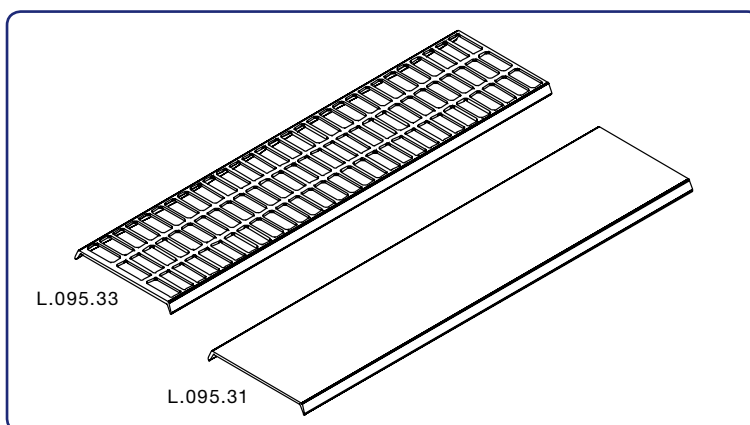

## B. Sills

A sill (type LZ.4140) can be fitted in the CL S to drain rain water off.

Fastener for a sill type LZ.4201

Instead of a sill, a frame can be used for the L.075 system (see item C).

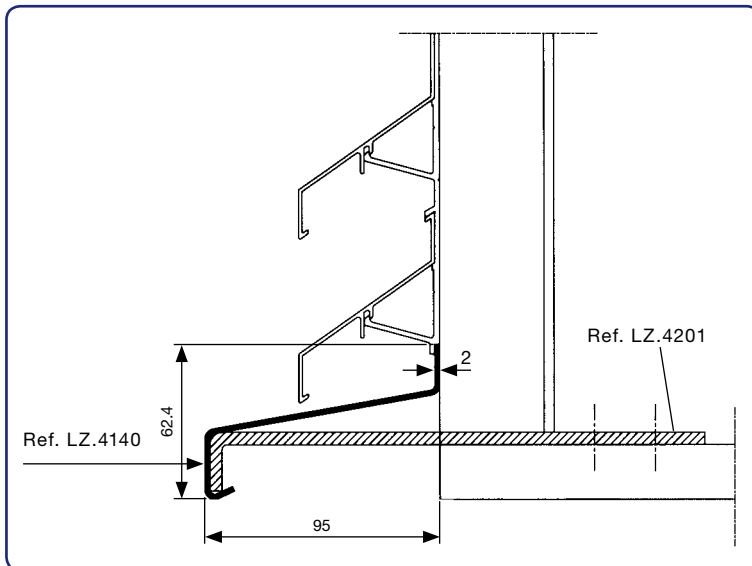

## C. Aluminium frames

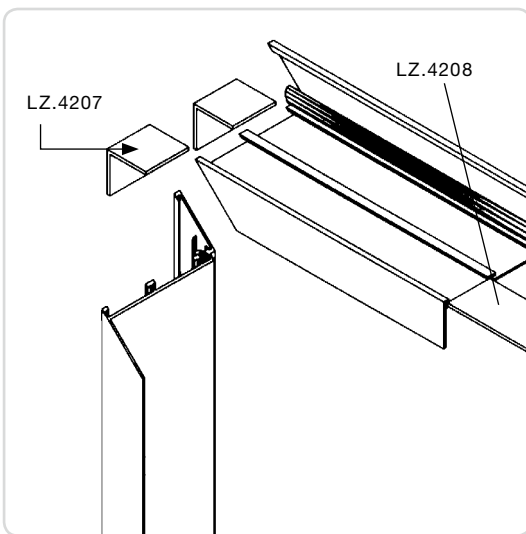
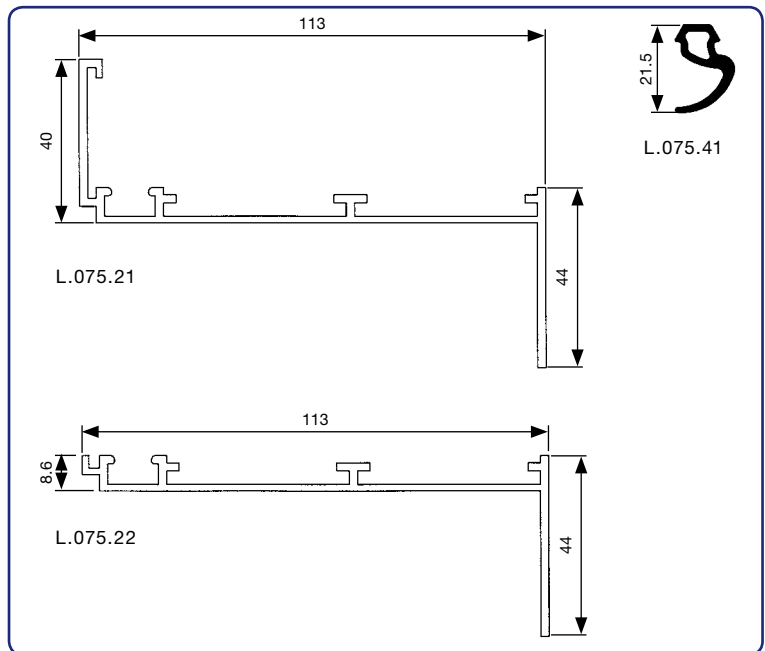

LZ.4207: Corner trim connector  
LZ.4208: Intermediate trim connector

The louvre system type 75 has been designed with the option of being provided with a frame with or without flange. The design with flange gives the aesthetically attractive appearance of a continuous blade surface.

**A sealing rubber can be used to give the louvre a perfect finish so use of silicone putty is unnecessary.**

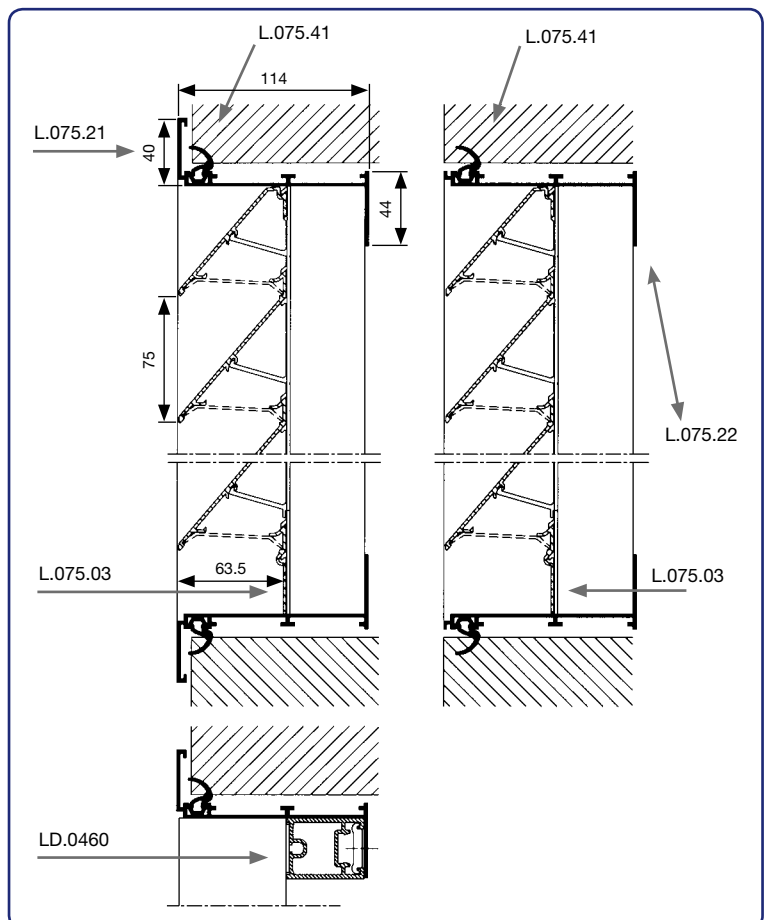

## D. Doors

RENSON® offers single or double doors in custom made sizes, opening inwards or outwards. In some cases, access behind the continuous louvre system is required, for example to maintain and service (hidden) industrial appliances.

The doors are fitted with locks, pivots, handles and restraining chain upon specification.



### Difference between overall size (O) and clear door opening (C)

Type blade:	L.033 / L.033.08		L.033V		L.050 / L.0050HF		L.050.021		L.060AC / L.060HF		L.065AL		L.066	
<b>O - C (mm)</b>	single	double	single	double	single	double	single	double	single	double	single	double	single	double
Opening outwards	259,5	399	259,5	399	259,5	399	259,5	399	279,5	439	259,5	399	259,5	399
Opening inwards	218	-	237	-	238,5	-	238,5	-	275,5	-	246	-	252,5	-

Type lamel:	L.066P		L.066V		L.066.21		L.075		L.095		L.120		L.150ACS	
<b>O - C (mm)</b>	single	double	single	double	single	double	single	double	single	double	single	double	single	double
Opening outwards	259,5	399	259,5	399	259,5	399	259,5	399	279,5	439	309,5	499	539,5	959
Opening inwards	252,5	-	246	-	252,5	-	261,5	-	275,5	-	288	-	365	-

Please note that the actual opening (C) is smaller than the total door size (O) due to the pivoting mechanism. The position of the pivot system will in turn depend on the total load of the louvre door. RENSON® can assist you in determining the correct sizes.

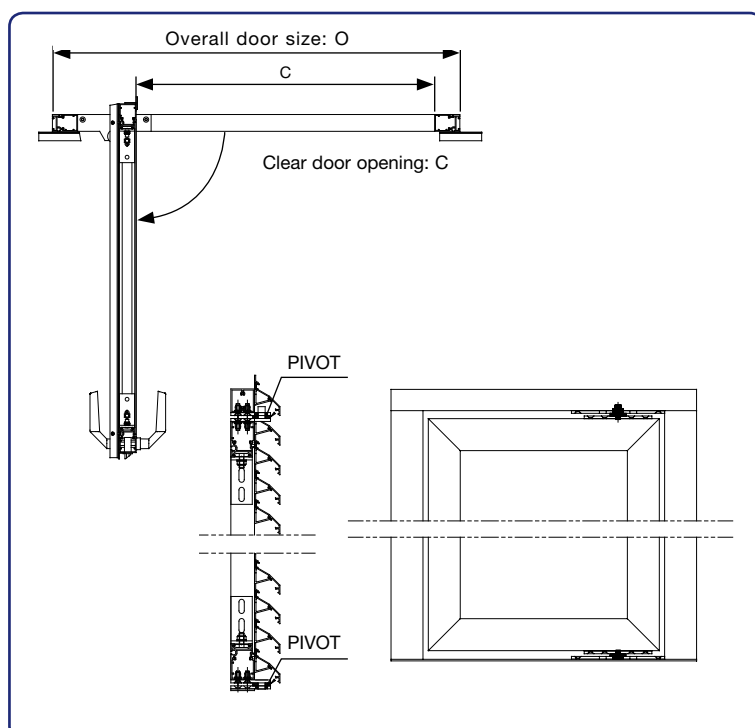

Pivots

# Accessories



## Handles and locks

One can choose between none, a single or a double door handle. If you choose not to fit a door handle you can open and close the door with the key to the lock. The handle can be a fixed door knob or a standard handle. It is important to specify the handle type.

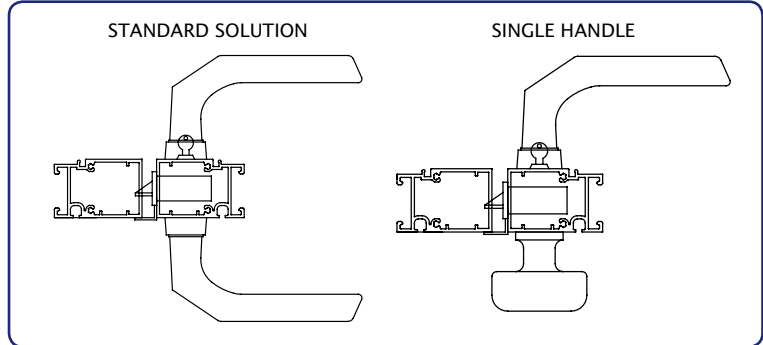

The Litto cylinder is the only approved option. Other proposals can be considered if full technical data is provided to RENSON®. Other types are available on request.

Accessories such as door dampers, storm chain,... are available on request.

## Door restrictor

A door restrictor is available as an option

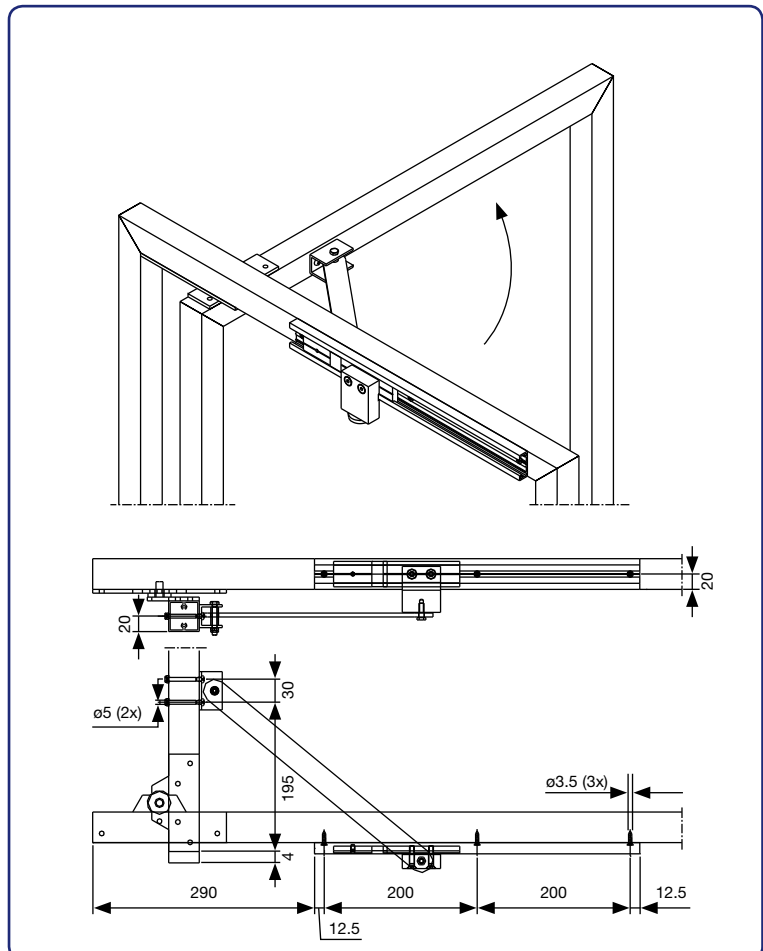

## A. Linius® unitized system

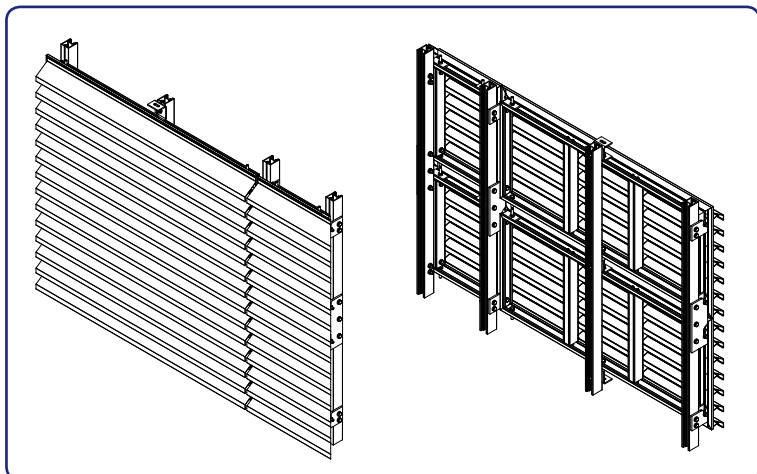

### Description

Innovative products are always challenging in terms of design, technique, flexibility and quality! To save valuable time in the assembly process on site, RENSON® developed the Linius® unitized system.

The advantage of this system is that it allows an entire louvre system to be divided into modules, which arrive on site in pre-assembled condition. Upon installation of the mullions on site, successive cassettes can be easily and quickly installed using a clasp system.

### Benefits

- Delivered as pre-assembled cassettes, hence:
  - quick installation, using clasped blades and simple clasp system
  - simple installation and alignment
  - easy assembly in hard-to-reach areas, e.g. high installations, only accessible from the interior ...
- Elements with invisible, encompassing frames
- Removable cassettes, e.g. machine areas
- Reclining elements possible
- Available with enfolded stainless steel mesh
- Elements for mitred corners possible
- Aesthetic appearance, solid and stable system

### Properties

- Max. dimensions: 4m<sup>2</sup> per element – 9 to 16kg/m<sup>2</sup>
- Cassette layout optional according to grid
- All Linius® range blades are suitable
- Assembly using lever for smaller cassettes  
OR using hoisting eye for larger cassettes and for high installations (crane)
- Technical documentation available

### Materials

Aluminium extrusion, alloy EN AW 6063 T66.

### Finish

- Anodised F1 (20 micron)
- Polyester powder coating RAL or Syntha Pulvin® colours (60 - 80 µ/40 µ (UK))

### Mesh

Enfolded assembly of stainless steel mesh to the back of the cassettes



hendel

hijsoog

# Specialties



## B. Curved blades

Today's designs often call for expressive forms giving a building a specific look.

RENSON® has developed a curved assembly system that allows the architect's creativity to be transformed into reality.

Blade types L.033.01, L.033HF, L.050.00 and L.050HF can be delivered with an minimal outer radius of 800 mm.

In addition, blade types L.033.01 and L.050.00 can also be curved with a minimal inner radius of 800 mm.

Plans for such a curved design must be submitted to the technical department at RENSON® for approval before the start of the construction process.

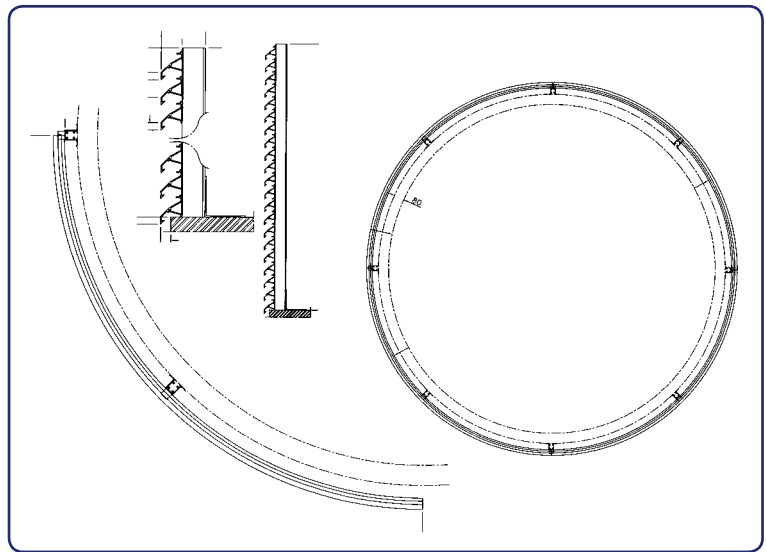

## C. Stand alone support structures

This system is used for freestanding louvre systems of limited sizes and/or wind loads where an additional primary steel structure is rendered unnecessary by a self-supporting aluminium structure.

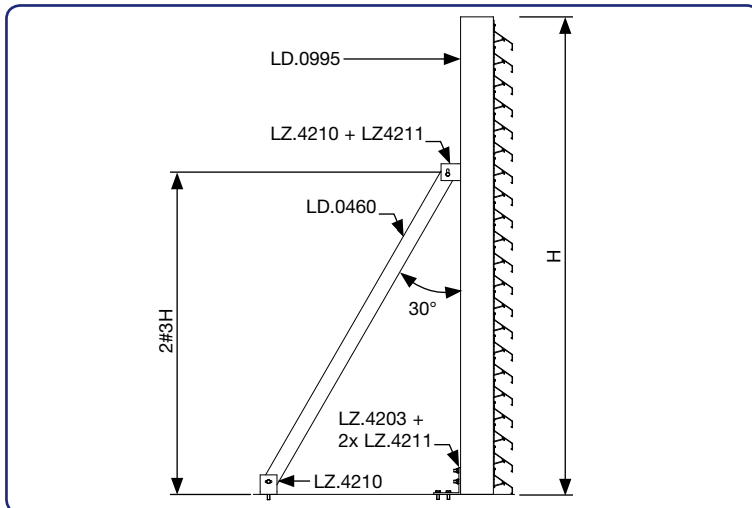

## D. Acoustic applications

Noise nuisance is an environmental pollutant.

We at RENSON® are fully aware of this. As a solution, RENSON® offers an acoustic louvre that reduces noise pollution and complies with existing regulations.

This acoustic louvre system allows air passage while reducing noise passage. The RENSON® technical department is at your disposal to advise and discuss a suitable acoustic construction.

In order to determine the ideal solution, the following factors are important:

- the desired dB noise level
- the noise level of the noise source
- the distance and location of the noise
- the required flow rate

The acoustic continuous louvre system consists of a support structure, acoustic blades and blade supports.

The acoustic blade is filled with sound absorbing and non-combustible mineral wool.

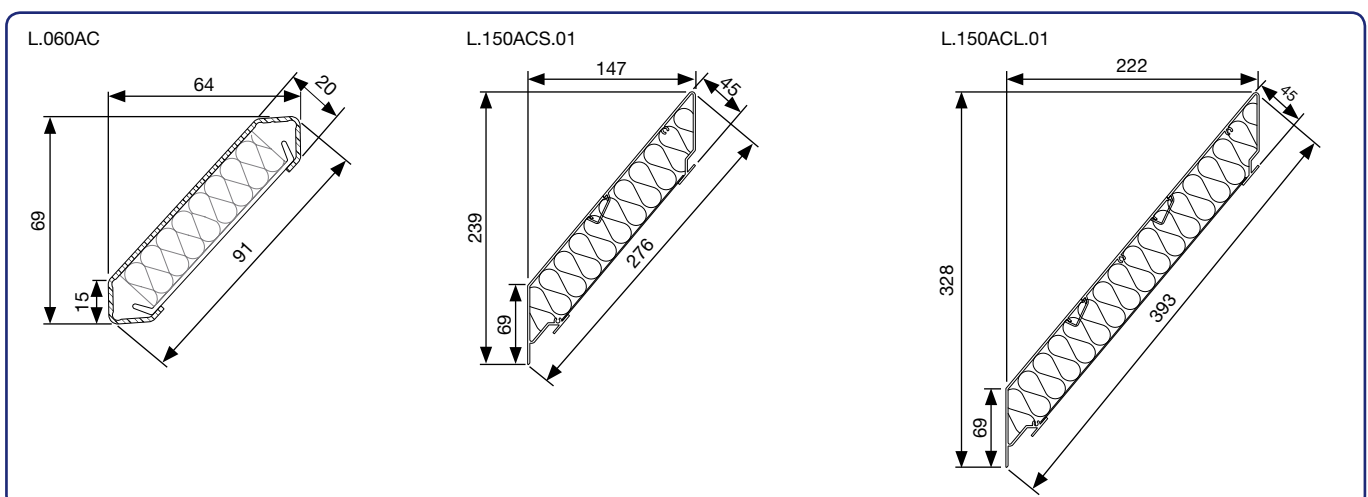

# Specialties



## E. Mitred corners

Where a corner is formed, the blades are cut to the correct angle so they fit perfectly and ensure an attractive aesthetic finish.

### Possible solutions to fit corners

1.

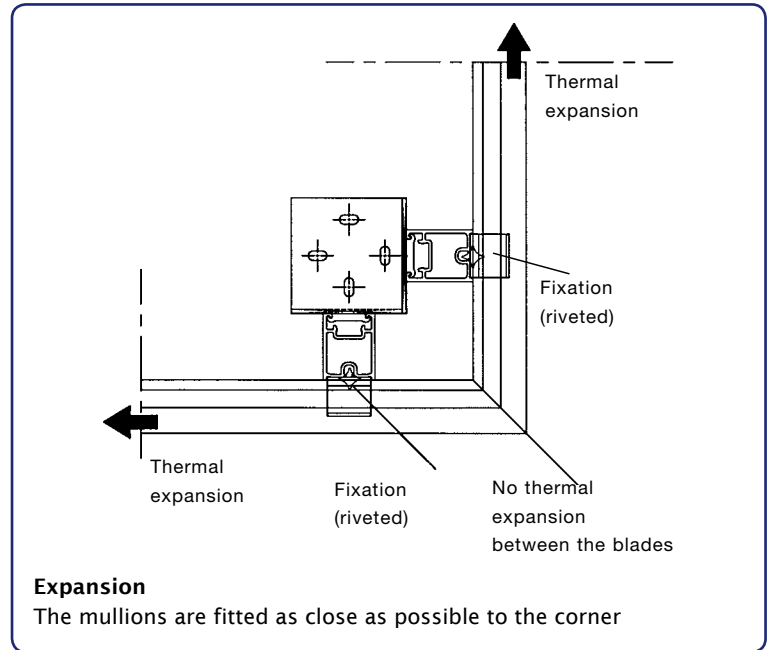

2.

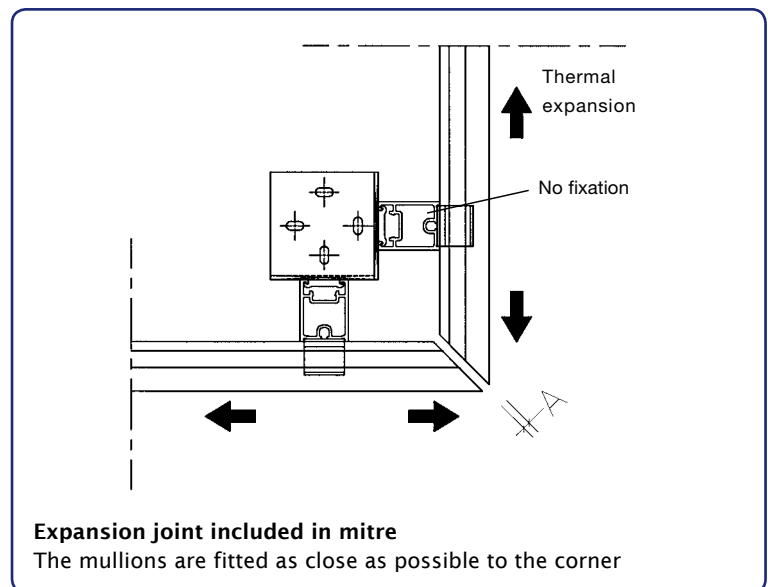

## F. Special shapes

RENSON® long ago moved on from the limits of a simple square design, and has continuously conceived solutions for specific applications.

These are applications mainly intended to create a certain aesthetic added value, but also applications where functional requirements must be combined with a contemporary design.

## G. Block blades L.033 and L.050

This type of blade offers fast and easy assembly and better vandalism-resistance than the standard aluminium CL S. The blades can only be used for riveting or screw-fixing to an existing full back structure (wall, metal sheeting, ...).

The extruded profiles are only available in types L.033 or L.050. They consist of 3 to 4 blades extruded together. The profiles are available as punched (L.033.07 / L.050.07) or unpunched (L.033.05 / L.050.05) versions. The block blades can be used in conjunction with the standard blades.

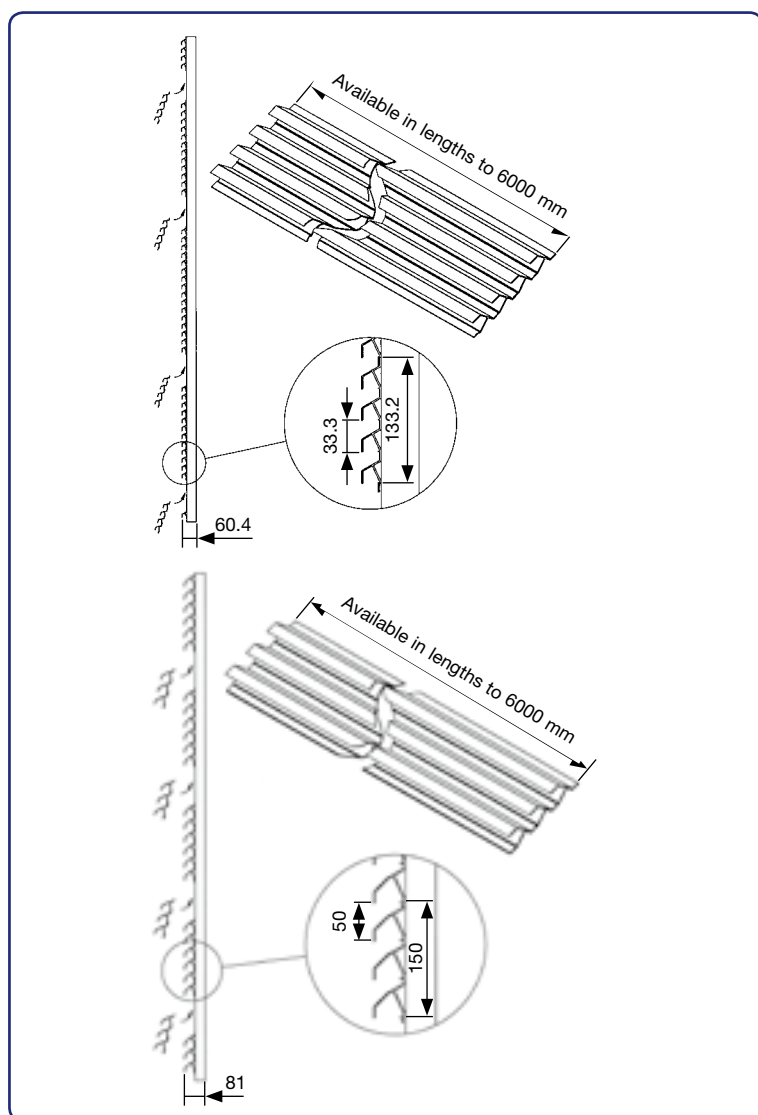

# Specialties



## H. Turrets

A turret is placed on the rooftop of buildings to conceal industrial appliances. (chimney stacks,....)

RENSON® takes care of complete construction including the top plate and sill.

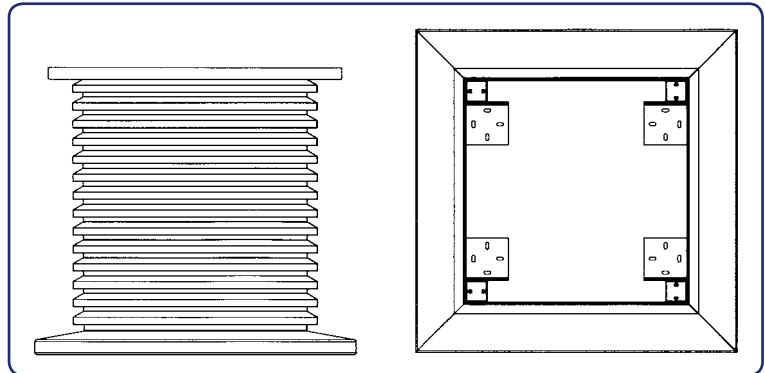

## I. Louvre grilles

Linius® CLS blades can also be used for assembled made-to-measure louvres. These louvres are made of frame profiles for building in or surface mounting, filled with a blade type depending on passage or aesthetic requirements, optionally fitted with a stainless steel insect mesh. The louvres grilles and louvre system can then be aesthetically matched. Louvre grilles are available in all forms, sizes, RAL colours, and as permanent or lockable versions. Louvre grilles with moving blades, sliding panels, or fixed or removable surface-mounted grilles for windows are also available.

SYSTEM	BLADE	BLADE TYPE	Pitch	GRILLE
L.033	L.033.01	Standard blade	33,3mm	411 ; 414 ; 414D ; 414VA ; 414THF ; 431 ; 432 ; 440/11
L.033.08	L.033.08	Labyrinthe blade	33,3mm	494
L.033V	L.033V	V-blade	33,3mm	422 ; 428
L.050	L.050.00	Standard blade	50mm	421 ; 424 ; 440/21
L.050HF	L.050HF	Blade with large free area	50mm	481 ; 484
L.060AC	L.060AC	Acoustic blade	60mm	445/86 ; 445/86GL
L.060HF	L.060HF	Blade with large free area	60mm	480 ; 483
L.065AL	L.065AL.01	Rolled sheet blade	65mm	453
L.066	L.066.01	Standard blade	66mm	451
L.066V	L.066V	V-blade	66mm	452 ; 452V
L.095	L.095.01	Standard blade	95mm	425 ; 425/GL
L.150ACL	L.150ACL.01	Acoustic blade	150mm	446/225
L.150ACS	L.150ACS.01	Acoustic blade	150mm	446/150
L.170ACL	L.150ACL.01	Acoustic blade	170mm	447/225
L.170ACS	L.150ACS.01	Acoustic blade	170mm	447/150

## J. Aesthetic façade cladding with Sunclips® and Icarus® blades

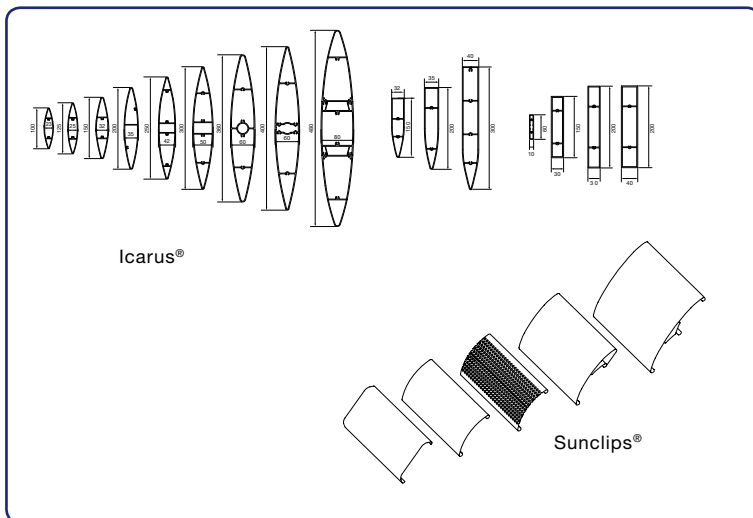

Besides the range of louvre systems, RENSON® also offers a whole range of aluminium profiles suitable for sunshading structures. One of the systems can be vertically fitted to act as a louvre. This structure is mainly intended for purely aesthetic applications and/or sunshading.

### Care of equipment and materials

To avoid deformation of blades etc. it is imperative to use 'soft handling' methods to unload and store materials. Deliveries on pallets may never be stacked more than two high to minimise exposing others on the site to risk.

To prevent damage during storage, handling or delivery one must comply with the following rules:

- the products are preferably stored inside.
- with open outside storage, remove the packaging to prevent the entry of water and any overheating.
- never place the elements directly on damp ground.
- during storage one must guarantee sufficient ventilation of the elements.
- soiling by cement, mortar or lime must be immediately removed with plenty of clean water.

Make sure that nearby material or installations cannot accidentally fall against the boxes and cause damage. The components are packed in wooden crates to protect them against damage. Packages and boxes are labelled with the content. The label has a bar code with the internal computer system reference. Where possible the link is made with the production drawings that can be sent with the goods.

Deliveries are planned so the correct material arrives in the correct place in the preferred order of use!



For more info see the Sunclips® and Icarus® brochures

# Storage and maintenance

## General instructions

### 1. INSTALLATING DOOR ELEMENTS

- For ease of transport, the leaves for large or double doors may be delivered loose. Fitting and removing door leaves: see “Instructions for assembly”
- In order to ensure that the blades in the CLS and those on the door are in line and so maintain the linearity of the louvre, it is recommended to first put the door element in place and only then to locate the support structures next to that element.
- They must be installed perfectly vertically on both sides to be sure the door will work properly. It is also very important for the batten at the base of the frame (and the pivot, especially) to be fully supported.
- It is fitted using brackets from Renson and anchoring materials specified and supplied by the installer.

### 2. INSTALLING INSECT, BIRD OR VERMIN MESH (OPTIONAL)

- PVC strips clipped between the blades after blade installation. These strips are available for blades L.050.01, L.075.01 and L.095.01.  
They are clipped in place by the lip of the blade.
- Stainless wire mesh V2A in 2.3 x 2.3 mm, 6 x 6 mm, 10 x 10 mm or 20 x 20 mm mesh (supplied on roll).  
The mesh is fixed to the substructure or the support structures.  
Suggestion: First attach an angle bracket to the support, then use a plate to bolt the mesh to the bracket.

### 3. INSTALLATION OF THE CONTINUOUS LOUVRE SYSTEM

#### 3.1 Thermal dilation

When planning and assembling the strip wall system and the dilation joint, the thermal expansion of the aluminium must always be taken into account. The thermal expansion coefficient of aluminium is 0.024 mm/mK (which is approximately equivalent to expansion of 1 mm/m with a rise in temperature of 40° C). In the event of major temperature fluctuations, the possibility of the harmless thermal expansion causing cracking sounds cannot be discounted.

To prevent that from happening as much as possible, it is important for the support profiles to which the strips are being attached, to be installed well in line and perfectly plumb. We also recommend using shorter strip lengths so that the total dilation per profile is kept to a minimum. Selecting the power-coated version also reduces that risk of dilation noise.

#### 3.2 Positioning and aligning support structures

- The following points must be taken into account when planning and before ordering a CLS:
  - the maximum allowable separation between the support structures is a function of the type of blade and support structure, and the local wind loading.
  - the vertical clearance between two attachment points is a function of the type of support structure, the clearance between two support structures and the local wind loading.  
For more details, see the Renson louvre documentation.
- Align the support structures with prefitted blade supports laterally such that the blade supports are all at the same height.  
Use suitable equipment such as a laser, cord, etc. to achieve this.  
If the height of the supports varies, the blades will not be even and the wall will lose its linear appearance.  
If the differences are large, the blade will not clip into the blade support.

## 3.3 Installing support structures at expansion joints

When installing aluminium systems, always allow for the thermal expansion of aluminium.

Its coefficient of thermal expansion is 0.024 mm/mK. To avoid blocking the expansion of the strips after assembly, you can choose from 2 possible methods at the level of the strip joints.

- **Option 1: Installing support structures with double blade support for two blades (type L.XXX.12)**

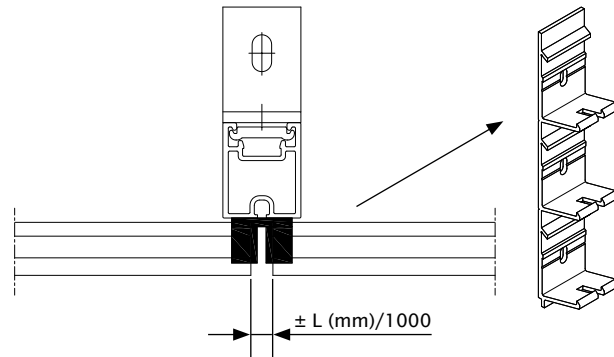

- **Option 2: Installing two separate support structures with prefitted standard blade supports (type L.XXX.11)**

This version is recommended especially for attachment to less regular substructures (e.g. wood) or where there are extreme variations in temperature.

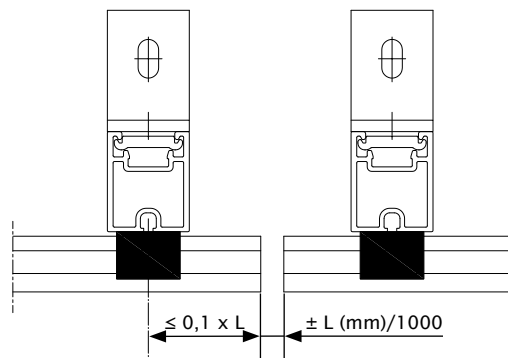

Locate the support structures as close as possible to the outer end of the blade. The clearance between the blade support and the end of the blade should not exceed 10% of the allowed free length of the blade.

## 4. Cleaning frequency

Aluminium elements exposed to regular rain and installed in a neutral atmosphere require thorough cleaning once or twice a year. Aluminium components situated in an urban or industrial environment need to be thoroughly cleaned at least twice a year. For coastal areas or areas with a strongly polluted atmosphere this frequency should be increased. Components not exposed to rain must be cleaned more frequently.

Further and more detailed information for installation are available on our website [www.renson.eu](http://www.renson.eu)

# Summary of RENSON® Linius® continuous louvre system

## Product description:

RENSON® Linius® CLS consists of sections of extruded ALMgSi0.5 aluminium with a surface treatment specified by the architect. The system consists of water-resistant ventilation blades, for simple and invisible assembly by clipping the blades into the blade supports included in the system

## Standards:

- Aluminium alloy: Al Mg Si 0,5 (F25)
  - Standard: EN AW-6063
  - Annealing: T66
- Strength calculations based on the following standards:
  - ENV 1999-1-1: calculation for aluminium structures
  - NBN B-03-002-2: wind load - dynamic effects
  - EN 1991-1-4: wind load

## Surface treatment:

- Anodised in natural colour F1 (20 micron): pre-treated and anodised
- Powder-coated in RAL colours (60 to 80 micron): aluminium profiles are pre-treated to ensure a firm powder coating, and then powder-coated

## System design:

### BLADES:

- Blade type L ..... of extruded aluminium
- Dimensions: Height: .....  
Depth: .....  
Pitch: .....
- Invisible assembly by clipping the blades into the corresponding blade support L .....11 and L .....12 (joint clips)
- Drag coefficient:  $C_{fy}$  (determined using wind tunnel tests): ..... (horizontal direction)  
 $C_{fz}$  (determined using wind tunnel tests): ..... (vertical direction)
- Visual free area: .....
- Physical free area: .....
- *K-FACTOR*: .....

### SUPPORT STRUCTURE

- Support profile LD..... of extruded aluminium:
- Dimensions: Height: .....  
Depth: .....
- Minimum moment of inertia  $I_y =$  ..... mm<sup>4</sup> (at 800Pa wind load)
- Blade clips are pre-assembled onto support profile
- Fixing brackets LZ. ....|

### SPAN:

- Maximum unsupported span of the said system, at  $q_b = 800$  Pa wind load:  
Blade: .....  
Support profile: .....

### SYSTEM DEPTH:

- Blade and support profile: .....

### ACCESSORIES:

- Encompassing frame L.075.21 with flange or L.075.22 without flange.
- Enrollable rubber seal L.075.41 for frame profiles L.075.21; L.075.22
- Corner trim connector LZ.4207 and intermediate trim connector LZ.4208 for frame profiles L.075.21 ; L.075.22
- PVC -strips L. .... .31, L. .... .32, L. .... .33 or L. .... .34 clicked between the blades - assembly from front possible
- Stainless steel 2.3 x 2.3; 6 x 6 or 20 x 20 mm mesh, attached to the back of the support structure
- Sill profile LZ.4140 and bracket LZ.4201

(Please strike out whichever is not applicable)

# References



Ref. Spree Dreilack, Berlin (DE), L.050 HF



Ref. Port City, Rotterdam (NL), L.050.01 curved



Arch. JSK Architekten (Dieter Schaffel),  
Q2 World Arena, Berlin (DE)



Arch. Weston Williamson, Sweeny Crescent (UK)



Millennium Towers, Budapest (HU)



Arch. Archikon BV, Amaliahof, Wissekerke (NL)



**Cherfan Draperies S.A.R.L., Jal El Dib Main Roan, P.O.Box 60-367 Beirut Lebanon**

**T + 961 4 710061 F + 961 4 719061 E [info@creashade.com](mailto:info@creashade.com) W [www.creashade.com](http://www.creashade.com)**

**Canada Branch: Creashade Canada Inc., 505 Industrial, Road Unit B2, Ottawa, Ontario K1G OZ1**

**T + 1 613 627 3959 M + 1 613 794 0097**