



CREASHADE
SUN SHADING SOLUTIONS



Creating healthy spaces

AESTHETIC NATURAL VENTILATION
WITH HIGH ACOUSTIC PERFORMANCE

Acoustic ventilation solutions



DOMESTIC USE



PROJECT USE

Contents

Introduction	2	Transit	
Acoustic performance definitions	3	Silendo®	28
Overview – acoustic performance table	4	468AK/2	29
Supply		Supply / extraction	
Sonovent®	6	468Ak/2	30
Sonovent® Compact	10	445/86	31
Sonovent® V	12	446/150	32
Sonovent® D	13	445/300	33
Invisivent® AK39	14	445B	34
Invisivent® ^{EVO} AK33	16	Linius® I.060Ac	35
AK80	18	Linius® I.150Acs	36
AK80 GL	20	Linius® I.150Acl	37
THK90 AK	22	Linius®	38
Screenvent® Mistral AK	24	Epilogue	
Slotvents	26	References	39

Introduction

The level and frequency of noise as well as the level of the non recognisable background sound should be taken into account when designing a sufficient sound absorbing facade. Not only the level of the external noise may vary but also the frequency. Fast traffic sounds are different than the lower motor noise of buses and other slow driving urban traffic. The sound of airplanes and trains has yet another sound.

This highlights the difficulties for low tone sound reductions when designing a facade.

In the UK there are no building regulations relating to acoustics, however Local Authority Planning Departments will set standards for some buildings. They will use the guidelines laid down in B.S. 8233 and also P.P.G. 24.

RENSON®, the specialist in acoustic ventilation.

As a specialist in natural ventilation RENSON® develops products which offer a solution for these issues. Our extensive R&D department has all of the latest technologies in order to accomplish the necessary analysis and tests.

- Our own acoustic test lab (in cooperation with WTCB)
- Test acoustic material and sound production measurements
- Definition of the product and material characteristic ventilation free area measurements
- Water- and windtightness
- Computer simulation
- Rapid prototyping

Our technical and quotation department support specific customer needs and convert them to an appropriate product request. They also offer an accurate advice concerning the use of the product according to the acoustic and air technical demands.

For more RENSON® products that offer aesthetic natural ventilation, ask your copy of our detailed catalogues 'Window Ventilators', 'Louvres, panels and grilles' or 'Linius®' (Continuous Louvre System).

Acoustic performance definitions

Acoustic terms

$D_{n,e,w}$ = weighted, element-normalised sound level difference, used to characterise small elements like ventilators.

R_w = weighted sound reduction index, used to characterise glazing, brick walls, wall louvres, etc.

C = spectrum correction term for pink noise, always added to R_w or $D_{n,e,w}$ when the source of the noise is, for example, fast-moving traffic.

C_{tr} = spectrum correction term for traffic noise, always added to R_w or $D_{n,e,w}$ when the source of the noise is, for example, urban traffic.

Frequency = pitch expressed in Hertz (Hz), or the number of vibrations per second.

Geometric terms for louvres

Visual free area = determined by the ratio between the visual distance between two blades (A) and the blade pitch (C).

Physical free area = determined by the ratio between the smallest gap between two blades (B) and the blade pitch (C). Owing to peripheral effects and assembly, a maximum deviation of 5% must be considered.

(The top and bottom blades are not taken into account in the two free area definitions).

The visual free area and physical free area are theoretical values. The real airflow must be calculated. Optimisation software is available free of charge on request.

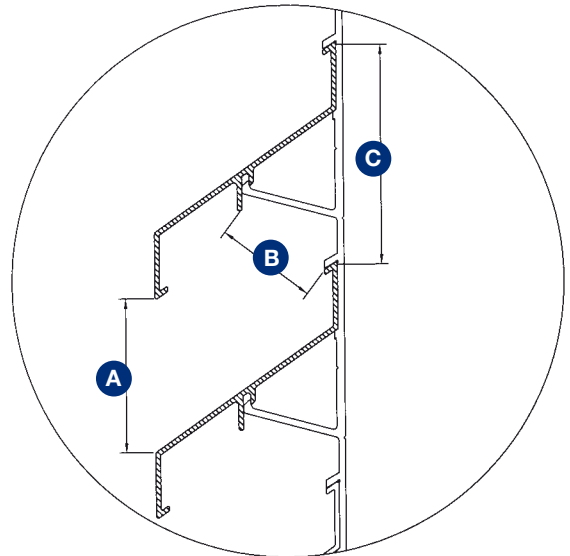

Aeraulic terms for louvres

K-factor = a value describing aerodynamic resistance to airflow. Contrary to the free area, this value describes the link between the airflow through the louvre and the pressure drop over it.

C_e = entry loss coefficient = a value describing the aerodynamic channelling of the airflow on entry. This value represents the ratio between the actual airflow compared with the theoretical airflow.

C_d = discharge loss coefficient = a value describing the aerodynamic channelling of the airflow on discharge. This value represents the ratio between the actual airflow compared with the theoretical airflow.

Introduction

Overview – Acoustic performance table

	Products	Sound reduction $D_{n,e,w}$ ($C;C_{tr}$) in dB	Page
Supply	AK80/1	47 (0;-3)	18
	AK80/2	44 (-1;-4)	18
	AK80/3	41 (-1;-3)	18
	AK80/4	33 (-1;-2)	18
	AK80 GL/1	47 (0;-3)	20
	AK80 GL/2	44 (-1;-4)	20
	AK80 GL/3	41 (-1;-3)	20
	AK80 GL/4	33 (-1;-2)	20
	Invisivent® EVO AK33	33 (-1;-2)	16
	Invisivent® AK39	39 (0;-2)	14
	Invisivent® AK41	41 (-1;-3)	14
	Invisivent® AK49	49 (-2;-5)	14
	Screenvent® Mistral AK Medium	33 (0;-1)	24
	Screenvent® Mistral AK Large	34 (0;-1)	24
	Sonovent® Compact 10mm	36 (0;-1)	10
	Sonovent® Compact 13mm	35 (0;-1)	10
	Sonovent® Compact 15mm	33 (0;-1)	10
	Sonovent® Large 10mm	50 (-2;-6)	6
	Sonovent® Large 15mm	49 (-2;-7)	6
	Sonovent® Large 20mm	44 (-2;-6)	6
	Sonovent® Large 25mm	41 (-2;-6)	6
	Sonovent® Medium 10mm	48 (-2;-6)	6
	Sonovent® Medium 15mm	45 (-2;-6)	6
	Sonovent® Medium 20mm	43 (0;-3)	6
	Sonovent® Medium 25mm	39 (-1;-4)	6
	Sonovent® Small 10mm	46 (-1;-5)	6
	Sonovent® Small 15mm	41 (-1;-2)	6
	Sonovent® Small 20mm	40 (-1;-3)	6
	Sonovent® Small 25mm	37 (-1;-2)	6
	Sonovent® V	35 (-1;-3)	12
	Sonovent® Xlarge 10mm	56 (-2;-6)	6
	Sonovent® Xlarge 15mm	53 (-2;-6)	6
	Sonovent® Xlarge 20mm	46 (-2;-6)	6
	Sonovent® Xlarge 25mm	45 (-2;-6)	6
	THK90 AK	29 (0;-1)	22
	471/1 + 470/30	39 (0;-1)	26
	471/2 + 470/30	40 (-1;-1)	26
	471/3 + 470/30	40 (-1;-1)	26
	771AK/2 + 686N/2	38 (0;-1)	26
	771AK/2 + 686N/3	37 (0;-1)	26
771AK/2 + 787AK/3 Aerovent® AK	40 (-1;-2)	26	
771AK/3 + 686N/4	36 (-1;-1)	26	
Transit	Silendo®	32 (0;-2)	28
	468AK/2	25 (-1;-2)	29
	Products	Sound reduction R_w ($C;C_{tr}$) in dB	Page
Extraction/supply	468AK/1	8 (-1;-2)	30
	445/86	6 (-1;-2)	31
	446/150	11 (-1;-2)	32
	445/300	16 (-1;-3)	33
	446B	19 (-1;-4)	34
	Linius® L.060AC	6 (-1;-2)	35
	Linius® L.150ACS	11 (-1;-2)	36
	Linius® L.150ACL	15 (-1;-4)	37

Overview – Acoustic performance table

Sound reduction $D_{n,e,w}$ (C;C _{tr}) in dB	Products	Page	
56 (-2;-6)	Sonovent® Xlarge 10mm	6	Supply
53 (-2;-6)	Sonovent® Xlarge 15mm	6	
50 (-2;-6)	Sonovent® Large 10mm	6	
49 (-2;-5)	Invisivent® AK49	14	
49 (-2;-7)	Sonovent® Large 15mm	6	
48 (-2;-6)	Sonovent® Medium 10mm	6	
47 (0;-3)	AK80/1	18	
47 (0;-3)	AK80 GL/1	20	
46 (-2;-6)	Sonovent® Xlarge 20mm	6	
46 (-1;-5)	Sonovent® Small 10mm	6	
45 (-2;-6)	Sonovent® Xlarge 25mm	6	
45 (-2;-6)	Sonovent® Medium 15mm	6	
44 (-2;-6)	Sonovent® Large 20mm	6	
44 (-1;-4)	AK80/2	18	
44 (-1;-4)	AK80 GL/2	20	
43 (0;-3)	Sonovent® Medium 20mm	6	
41 (-2;-6)	Sonovent® Large 25mm	6	
41 (-1;-3)	AK80/3	18	
41 (-1;-3)	AK80 GL/3	20	
41 (-1;-3)	Invisivent® AK41	14	
41 (-1;-2)	Sonovent® Small 15mm	6	
40 (-1;-2)	771AK/2 + 787AK/3 Aerovent AK	24	
40 (-1;-1)	471/2 + 470/30	24	
40 (-1;-1)	471/3 + 470/30	24	
40 (-1;-3)	Sonovent® Small 20mm	6	
39 (-1;-4)	Sonovent® Medium 25mm	6	
39 (0;-2)	Invisivent® AK39	14	
39 (0;-1)	471/1 + 470/30	24	
38 (0;-1)	771AK/2 + 686N/2	24	
37 (-1;-2)	Sonovent® Small 25mm	6	
37 (0;-1)	771AK/2 + 686N/3	24	
36 (-1;-1)	771AK/3 + 686N/4	24	
36 (0;-1)	Sonovent® Compact 10mm	10	
35 (-1;-3)	Sonovent® V	12	
35 (0;-1)	Sonovent® Compact 13mm	10	
34 (0;-1)	Screenvent® Mistral AK Large	24	
33 (0;-1)	Screenvent® Mistral AK Medium	24	
33 (-1;-2)	AK80/4	18	
33 (-1;-2)	AK80 GL/4	20	
33 (-1;-2)	Invisivent® ^{EVO} AK33	16	
33 (0;-1)	Sonovent® Compact 15mm	10	
29 (0;-1)	THK90 AK	22	
32 (0;-2)	Silendo®	28	Transit
25 (-1;-2)	468AK/2	29	
Sound reduction R_w (C;C _{tr}) in dB	Products	Page	
19 (-1;-4)	446B	34	Extraction/supply
16 (-1;-3)	445/300	33	
15 (-1;-4)	Linius® L.150ACL	37	
11 (-1;-2)	Linius® L.150ACS	36	
11 (-1;-2)	446/150	32	
8 (-1;-2)	468AK/1	30	
6 (-1;-2)	445/86	31	
6 (-1;-2)	Linius® L.060AC	35	

SUPPLY > Sonovent®

Self regulating ventilator with a superior sound absorption

Introduction

RENSON® has developed the Sonovent® to meet two aspects of living comfort:

Physical comfort:

fresh and healthy air without draughts

Acoustic comfort:

up to 50 dB sound reduction

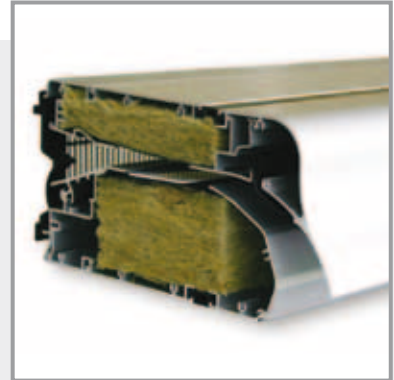

Section details

- ① Aluminium ventilation box with thermal bridges
- ② Easy to clean because of the removable inner profile
- ③ Acoustic elements are removable from the inside
- ④ Inner flap for ventilation control
- ⑤ Self regulating element: avoids draughts and saves energy
- ⑥ Frame profile

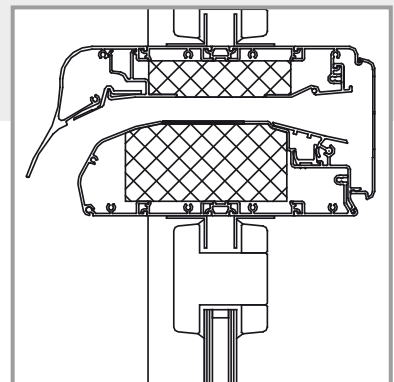

Advantages

- Hidden installation possible for maximum respect of the architecture
- Self regulating ventilation (class P3) in order to avoid draughts and to minimize energy losses
- Secure ventilation with closed windows: insect-, burglar- and rainproof
- Thermally broken profiles. These thermal bridges can be positioned according to the type and installation
- Easy to maintain because of the removable parts
- Integrated solution for acoustics and ventilation
- Can be glazed into windows and curtain walling



A new standard in acoustic ventilation

The Sonovent® combines the best air sound insulation with the most comfortable ventilation by means of a self regulating element which reduces the air inlet even by the smallest air pressure on the facade. According to this patented principle the Sonovent® avoids draughts and saves energy.

Relation air flow pressure drop of RENSON® Sonovent® according to the SIGHT report PO30007-07-02.

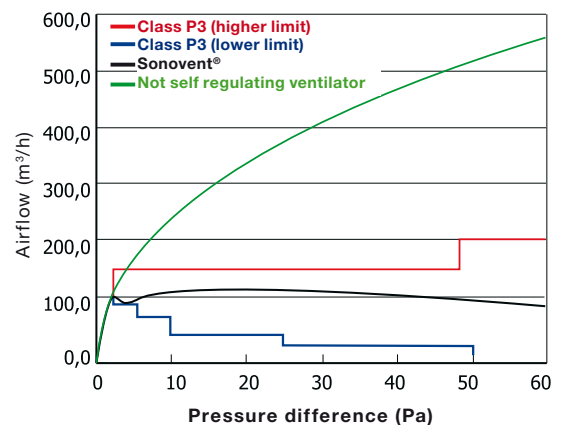

Material

- Profiles: aluminium AlMgSi 0.5 (according to EN 12020-2)
- Finishing: powdercoated in any RAL or Syntha Pulvin® colour (dual colour possible)
- Endcaps in ASA polymer type Luran S (colourfast, weather- and UV-resistant)
- Sound-reducing material: non combustible mineral wool

Dimensions

Height: 105mm
Glass reduction: 135 mm
Glass thickness: 20, 24, 28 & 32 mm as standard.
Other thicknesses available on demand.



Controls

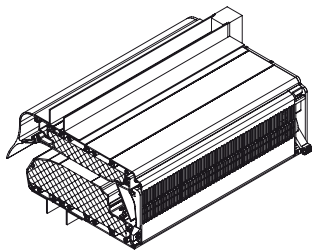

Manual control

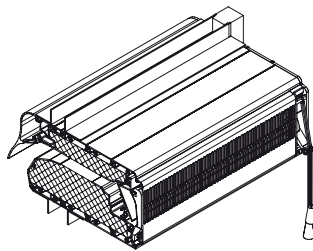

Cord control

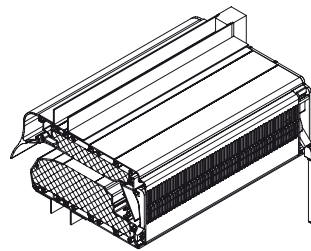

Rod control
(hook-up)
nr. 134

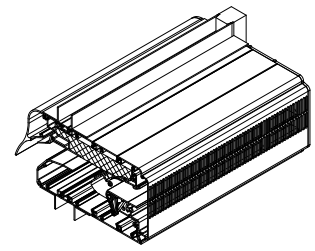

Motor control

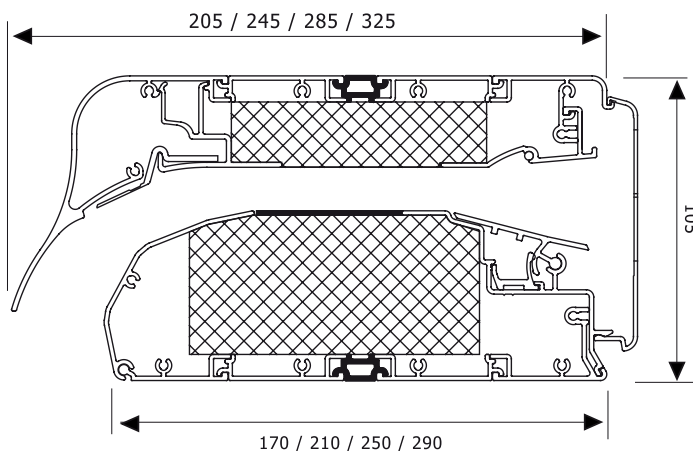

Available models

Four types of the Sonovent® are available: Small, Medium, Large and XLarge. Each type has 4 free area possibilities (air slot: 10, 15, 20 or 25 mm). This comes up to 16 alternatives in total, which means that each situation of noise nuisance can be solved.

The Sonovent® is always made to measure with a maximum length of 2000 mm (installation on glass) or a maximum length of 2500 mm (installation at transom).

SUPPLY > Sonovent®

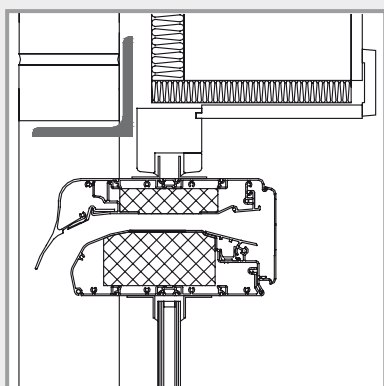

Installation on glass

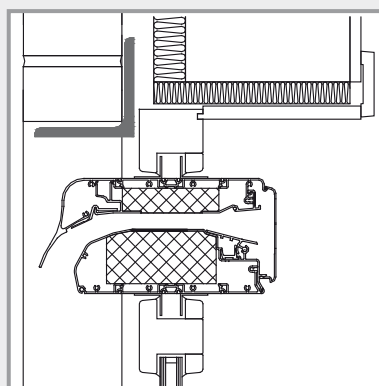

Installation between profiles

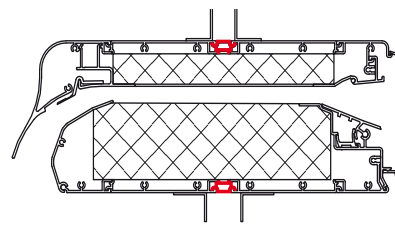
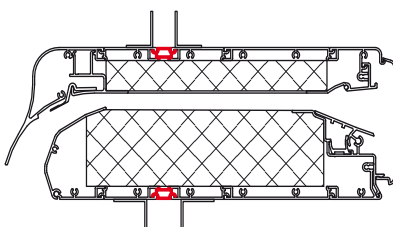
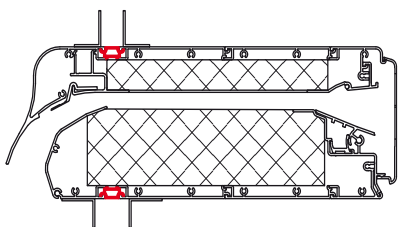

The position of the thermal bridge can be chosen by the customer: 3 possible positions are available for the Sonovent® Small, 4 for the Medium, 5 for the Large and 6 for the XLarge.

Applications

- On all types of window frames: aluminium, timber and PVC
- Can be used for new buildings as well as for renovation
- For residential dwellings as well as hospitals, offices, schools and many other commercial applications
- Can be installed on glass or between profiles (at transom).

Special application for curtain walling

Hidden installation in a ventilated panel of a curtain wall system.

By varying the length, the required air flow together with the necessary acoustic performances can be reached.

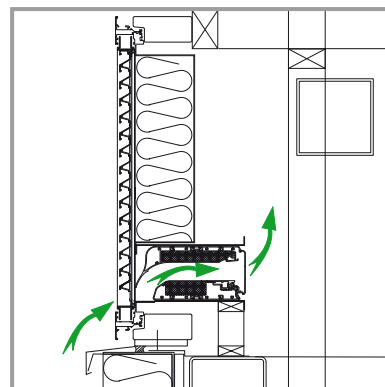
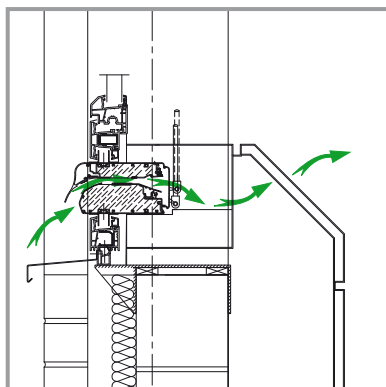
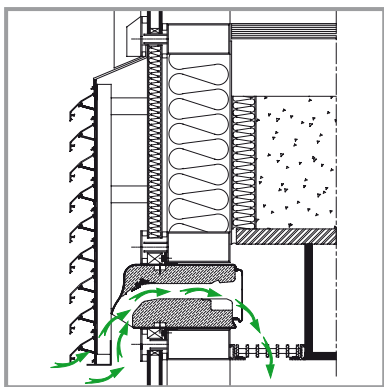

Technical specifications

	Small	Medium	Large	Xlarge
AIRFLOW				
Airflow at 2 Pa				
Air slot 10 mm	50,2 m ³ /h/m	49,5 m ³ /h/m	45,7 m ³ /h/m	40,8 m ³ /h/m
15 mm	83,7 m ³ /h/m	75,0 m ³ /h/m	72,2 m ³ /h/m	61,0 m ³ /h/m
20 mm	90,0 m ³ /h/m	94,2 m ³ /h/m	90,7 m ³ /h/m	87,9 m ³ /h/m
25 mm	95,6 m ³ /h/m	96,3 m ³ /h/m	94,5 m ³ /h/m	92,4 m ³ /h/m
Airflow at 2 Pa				
Air slot 10 mm	14,0 l/s/m	13,8 l/s/m	12,7 l/s/m	11,3 l/s/m
15 mm	23,3 l/s/m	20,8 l/s/m	20,1 l/s/m	17,0 l/s/m
20 mm	25,0 l/s/m	26,2 l/s/m	25,2 l/s/m	24,4 l/s/m
25 mm	26,6 l/s/m	26,7 l/s/m	26,3 l/s/m	25,7 l/s/m
Airflow at 1 Pa				
Air slot 10 mm	14,0 l/s/m	13,8 l/s/m	12,7 l/s/m	11,3 l/s/m
15 mm	23,3 l/s/m	20,8 l/s/m	20,1 l/s/m	17,0 l/s/m
20 mm	25,0 l/s/m	26,2 l/s/m	25,2 l/s/m	24,4 l/s/m
25 mm	26,6 l/s/m	26,7 l/s/m	26,3 l/s/m	25,7 l/s/m
Equivalent area				
Air slot 10 mm	17756 mm ² /m	17509 mm ² /m	16153 mm ² /m	14427 mm ² /m
15 mm	29593 mm ² /m	26511 mm ² /m	25524 mm ² /m	21578 mm ² /m
20 mm	31813 mm ² /m	33292 mm ² /m	32059 mm ² /m	31073 mm ² /m
25 mm	33786 mm ² /m	34032 mm ² /m	33416 mm ² /m	32676 mm ² /m
COMFORT				
Sound reduction in open position $D_{n,e,w}$ (C;C _{tr}) (EN ISO 140-10, EN ISO 717-1)				
Air slot 10 mm	46 (-1;-5) dB	48 (-2;-6) dB	50 (-2;-6) dB	56 (-2;-6) dB
15 mm	41 (-1;-2) dB	45 (-2;-6) dB	49 (-2;-7) dB	53 (-2;-6) dB
20 mm	40 (-1;-3) dB	43 (0;-3) dB	44 (-2;-6) dB	46 (-2;-6) dB
25 mm	37 (-1;-3) dB	39 (-1;-4) dB	41 (-2;-6) dB	45 (-2;-6) dB
Sound reduction in closed position $D_{n,e,w}$ (C;C _{tr}) (EN ISO 140-10, EN ISO 717-1)				
Air slot 10 mm	n.p.d.			
15 mm				
20 mm				
25 mm				
Self regulating	yes (class P3)			
TECHNICAL CHARACTERISTICS : (EN 13141-1)				
U-value	4,5 W/m ² K	4,6 W/m ² K	4,6 W/m ² K	4,7 W/m ² K
Watertightness (closed position)	650Pa			
Windtightness	650Pa			

SUPPLY > Sonovent® Compact

Compact self regulating acoustic window vent

Introduction

The Sonovent® Compact is, as the name indicates, a compact version of the well-known Sonovent®, with good results regarding acoustic values and airflow. This Sonovent® Compact is available for installation on glass or at transom and is applicable on all types of window frames : aluminium, timber and uPVC*.

Material

- Inside and outside profile: aluminium AlMgSi 0.5 (according to EN12020-2)
- Finishing: satin anodised or powdercoated in any RAL or Syntha Pulvin® colour (dual colour possible)
- Black endcaps in ASA polymer type Luran S (colourfast, weather- and UV-resistant)
- Sound-reducing material: non combustible mineral wool



Dimensions

Glass reduction: 78 mm

Height: 95 mm

Glass thickness: 20, 22, 24, 28, 32 & 36 mm

Controls

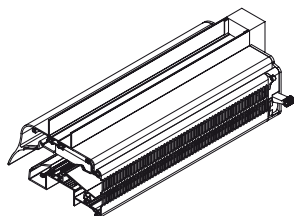

Manual control

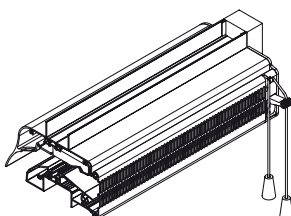

Cord control

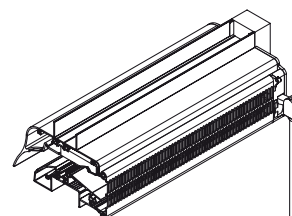

Rod control
(hook-up)
nr. 134

Available models

The Sonovent® Compact is available with three different air slots (10, 13 or 15 mm) and is only custom made (made to measure) with a maximum length of 2000 mm (installation on glass) or a maximum length of 2500 mm (installation at transom).

Section details

- ① Easy removable inner profile for cleaning purpose
- ② Inner flap for ventilation control
- ③ Self regulating flap: avoids draughts and saves energy

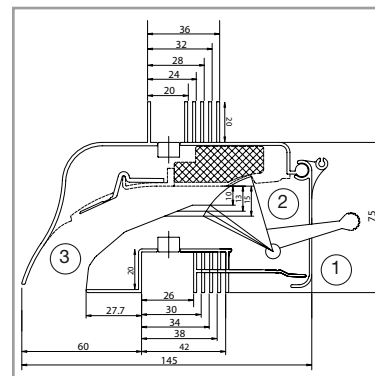

Technical specifications

	Sonovent® Compact
AIRFLOW	(EN 13141-1)
Airflow at 2 Pa	46,6 m³/h/m
Air slot 10 mm	58,9 m³/h/m
13 mm	67,7 m³/h/m
15 mm	71,5 m³/h/m
Airflow at 2 Pa	
Air slot 10 mm	16,4 l/s/m
13 mm	18,8 l/s/m
15 mm	19,9 l/s/m
Airflow at 1 Pa	
Air slot 10 mm	12,1 l/s/m
13 mm	15,2 l/s/m
15 mm	19,4 l/s/m
Equivalent area	
Air slot 10 mm	15334 mm²/m
13 mm	19278 mm²/m
15 mm	24687 mm²/m
COMFORT	(EN ISO 140-10, EN ISO 717-1)
Sound reduction $D_{n,e,w}$ (C;C _{tr}) in open position	
Air slot 10 mm	36 (0;-1) dB
13 mm	35 (0;-1) dB
15 mm	33 (0;-1) dB
Sound reduction $D_{n,e,w}$ (C;C _{tr}) in closed position	
Air slot 10 mm	
13 mm	n.p.d.
15 mm	
Self regulating	Yes (class P3)
TECHNICAL CHARACTERISTICS	
U-value	6,0 W/m²K
Watertightness (closed position)	650 Pa
Windtightness	650 Pa

* For installation on aluminium and uPVC windows: please contact us for more information.

SUPPLY > Sonovent® V

Mechanical ventilator with a superior sound absorption

Mechanical ventilator

This mechanical ventilator, provided with a 24V fan, has an airflow of maximum 220m³/h/m. The Sonovent® V is only available as 1 type: small and two models (one for extraction and one for supply).

The ventilator is efficient for the supply of fresh air and the extraction of consumed air (not suitable as kitchen or bathroom extractor). The ventilator starts to work automatically when opening the flap and is controllable by means of a variable speed controller. The mechanical parts and the acoustic insulation are removable from the interior. Flap can be controlled manually, with a rod or with a motor control.

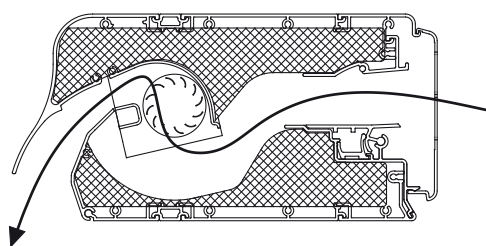

Sonovent® V-extraction

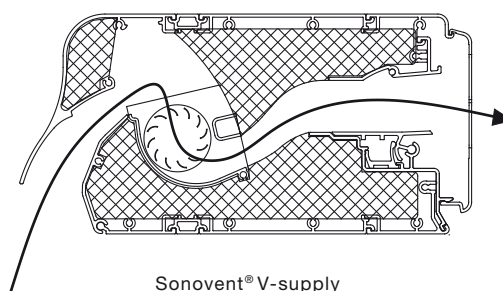

Sonovent® V-supply

Technical specifications

		Sonovent® V
AIRFLOW		
	Supply	220 m ³ /h/m
	Supply	61,11 l/s/m
	Extraction	220 m ³ /h/m
	Extraction	61,11 l/s/m
COMFORT		
	Sound reduction D _{n,e,w} (C;C _{tr})	(EN ISO 140-10, EN ISO 717-1)
	- in open position	35 (-1;-3) dB
	- in closed position	n.p.d.
TECHNICAL CHARACTERISTICS		
	U-value	4,5 W/m ² K
	Watertightness (closed position)	650 Pa
	Windtightness	600 Pa

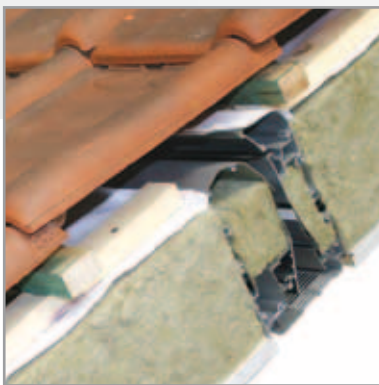

Special applications for ventilation in rooms under roof

It is sometimes not easy to reach the ventilation standards for rooms under the roof which can not be equipped with vertical windows.

The ventilation slots of roof windows do not provide enough air flow and opening windows is acoustically not interesting. Extra protection for rain and insects can also be required.

This is why a Sonovent® D is the best solution for installation in the roof segment with ventilation tiles. This hidden installation assures total watertightness in closed position up to 650 Pa and in open position up to 100 Pa. The Sonovent® D is available in three types (Small, Medium and Large) and can be installed from the inside and from the outside when building the roof.

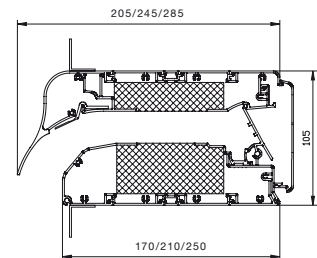
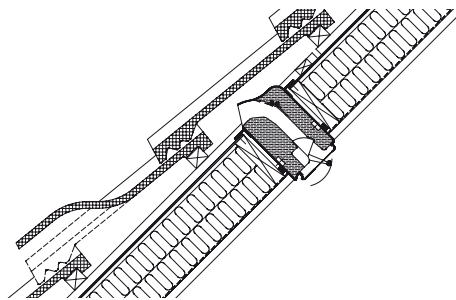

Technical specifications

	Small	Medium	Large
AIRFLOW			
2 Pa	100,8 m ³ /h/m (tiles) • 86,3 m ³ /h/m (slates)		
2 Pa	28,0 l/s/m (tiles) • 24,0 l/s/m (slates)		
1 Pa	28,0 l/s/m (tiles) • 24,0 l/s/m (slates)		
Equivalent area	33786 mm ² /m	34032 mm ² /m	33416 mm ² /m
COMFORT			
Sound reduction D _{n,e,w} (C;C _{tr})	(EN ISO 140-10, EN ISO 717-1)		
- in open position	37 (-1;-3) dB	39 (-1;-4) dB	41 (-2;-6) dB
- in closed position	n.p.d.	n.p.d.	n.p.d.
Self regulating	yes (class P3)		
TECHNICAL CHARACTERISTICS			
U-value	4,5 W/m ² K		
Watertightness (closed position)	650 Pa		
Windtightness	650 Pa		

SUPPLY > Invisivent® AK

Invisible sound absorbing overframe ventilator

Introduction

To give the Invisivent® (see our catalogue 'Window Ventilators') an acoustic performance, three different acoustic extension boxes have been developed. Like the standard Invisivent®, the Invisivent® AK is available in 6 different types, depending on the depth of the windowframe. Combined with the 3 different acoustic boxes (different airflows), the Invisivent® AK range includes 18 models.

Material

- Inside and outside profile: aluminium AlMgSi 0.5 (according to EN 12020-2)
- Finishing: satin anodised or powdercoated in any RAL or Syntha Pulvin® colour (dual colour possible)
- Endcaps in ASA polymer type Luran S (colourfast, weather- and UV-resistant)
- Endcaps are also available in any colour upon request (dual colour possible)
- Sound-reducing material: absorbent foam

Dimensions

Glass reduction : 0 mm

Overall height : 59 mm

9 types are available, depending on the width of the windowframe :

Invisivent®: 50 – 64 mm, 65 – 79 mm, 80 – 94 mm

Invisivent® XL: 95 – 109 mm, 110 – 124 mm, 125 – 139 mm

Invisivent® XXL : 140 – 154 mm, 155 – 169 mm, 170 – 184 mm

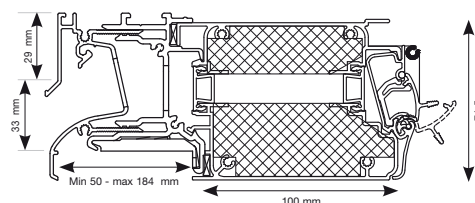
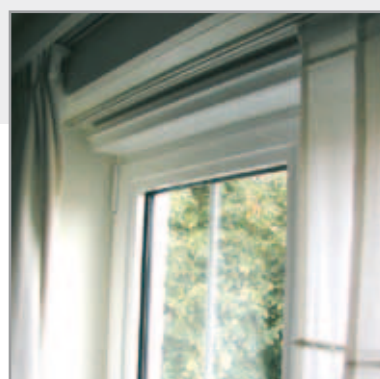

Controls

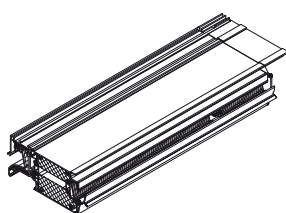

Manual control

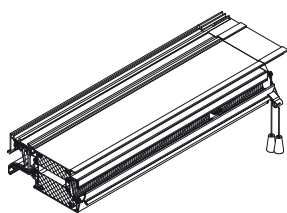

Cord control

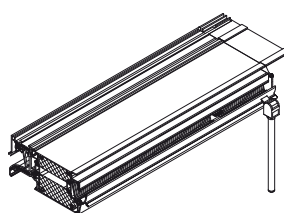

Rod control
(hook-up)
nr. 134

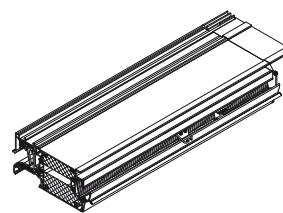

Motor control

Availability

Invisivent®AK is only available made to measure.

Section details

- ① Aluminium box with thermal bridges
- ② Easy maintenance thanks to the removable inner profile
- ③ Sound absorbing acoustic material
- ④ Inner flap in order to control the ventilation level
- ⑤ Window profile

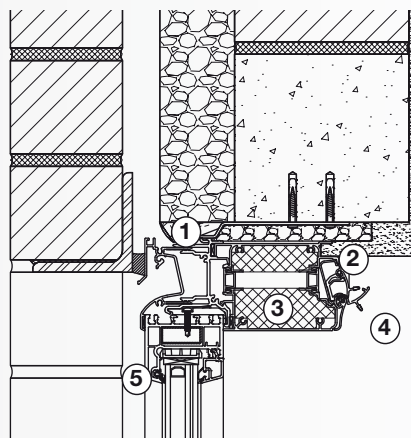

Advantages

Hidden installation for maximum respect of the architecture.
 Secure ventilation with closed windows; insect-, burglar- and rainproof.
 Thermally broken profiles.

Options

There is a slot at the inner side which allows a finishing profile or a plaster board to 10 mm.
 For thicker finishing profiles, plasterboards or plastering, an optional aluminium profile can be provided.

Technical specifications

	Invisivent® AK39	Invisivent® AK41	Invisivent® AK49
AIRFLOW			
2 Pa	33,3 m³/h/m	15,7 m³/h/m	9,0 m³/h/m
2 Pa	9,2 l/s/m	4,4 l/s/m	2,5 l/s/m
1 Pa	6,5 l/s/m	3,1 l/s/m	1,8 l/s/m
Equivalent area	8311 mm²/m	3922 mm²/m	2241 mm²/m
COMFORT			
Sound reduction $D_{n,e,w}$ ($C;C_{tr}$)	(EN ISO 140-10, EN ISO 717-1)		
- in open position	39 (0;-2) dB	41 (-1;-3) dB	49 (-2;-5) dB
- in closed position	48 (0;-2) dB	46 (-1;-2) dB	57 (-1;-3) dB
Self regulating	no		
TECHNICAL CHARACTERISTICS			
U-value	4,5 W/m²K		
Watertightness (closed position)	650 Pa		
Windtightness	650 Pa		

SUPPLY > Invisivent® EVO AK33

Invisible self regulating sound absorbing overframe ventilator

Introduction

The Invisivent® EVO AK33 is a thermally broken, self regulating flap ventilator with a sound absorbing performance for installation above an aluminium, timber or uPVC window frame.

The Invisivent® EVO AK33 is available in 2 different types:

- Invisivent® EVO AK33 for new installations
- AKR33-module for installation on a previously installed Invisivent®

The Invisivent® EVO AK33 is the most discrete acoustic vent worldwide.

The Invisivent® EVO is available in two different styles of innerflap. You can choose from either a sleek modern flap (Invisivent® EVO Futuro), ideal for modern minimalist housings; or a flap with a soft rounded shape (Invisivent® EVO Classico), suited for more rural cottage housings.

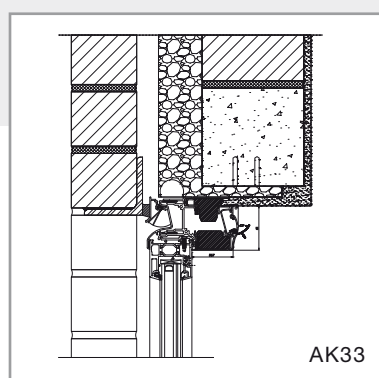
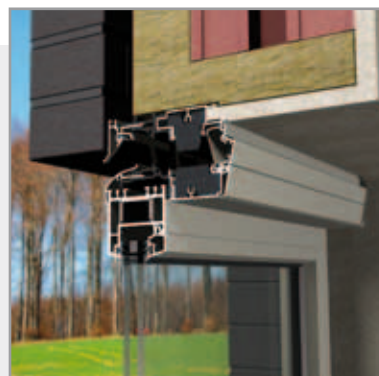

AK33

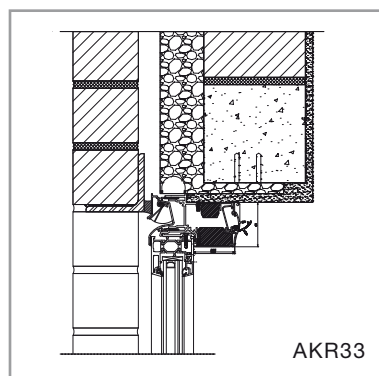

AKR33

Material

- Inside and outside profile: aluminium AlMgSi 0.5 (according to EN 12020-2)
- Finishing: satin anodised or powdercoated in any RAL or Syntha Pulvin® colour (dual colour possible)
- Endcaps in ASA polymer type Luran S (colourfast, weather- and UV-resistant)
- Endcaps are also available in any colour upon request (dual colour possible)
- Sound-reducing material: absorbent foam

Dimensions

Glass reduction: 0 mm

Overall height: 59 mm

9 types are available, depending on the width of the windowframe:

Invisivent®AK33: 50 – 64 mm, 65 – 79 mm, 80 – 94 mm, 95 – 109 mm, 110 – 124 mm, 125 – 139 mm, 140 – 154 mm, 155 – 169 mm, 170 – 184 mm

Controls

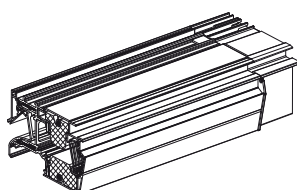

Manual control

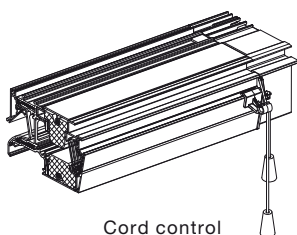

Cord control

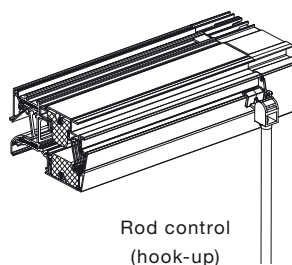

Rod control
(hook-up)
nr. 134

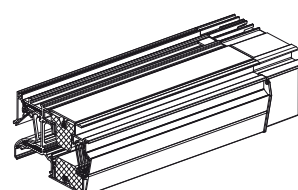

Motor control

Assembly

Developed for fabrication from bar lengths (6000mm) or made to measure.

Cut (length Invisivent® EVO AK33 = overall width of windowprofile) ventilator to size from a bar length, fix endcaps (1L+1R).

Assembly: fix a support profile on the window frame, clip the ventilator onto the support profile, push the inner profile into the outer profile uniformly onto the window frame, clip the acoustic AK(R) module onto the ventilator.

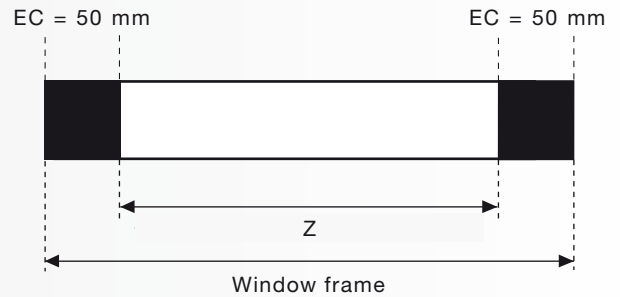

Section details

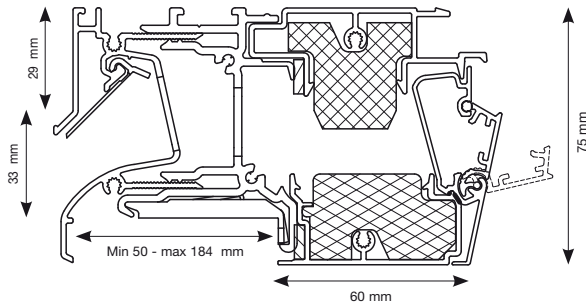

The Invisivent® EVO & AK33 module for new installations

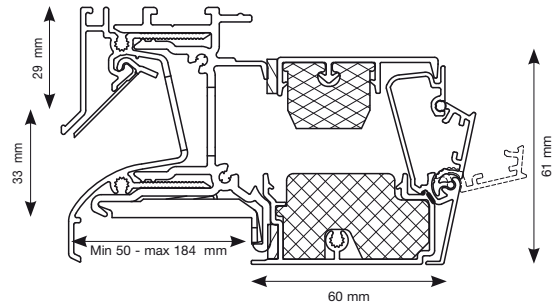

The Invisivent® EVO & AKR33 module for installation on a previously installed Invisivent®

Technical specifications

		Invisivent® EVO AK33
AIRFLOW		(EN 13141-1)
	2 Pa	46,6 m³/h/m
	2 Pa	12,9 l/s/m
	Equivalent area	11818 mm²/m
COMFORT		
Sound reduction $D_{n,e,w}$ (C;C _{tr})		(EN ISO 140-10, EN ISO 717-1)
	- in open position	33 (-1;-2) dB
	- in closed position	46 (0;-2) dB
	Self regulating	yes (class P3)
TECHNICAL CHARACTERISTICS		
	U-value	3,6 W/m²K
	Watertightness (closed position)	650 Pa
	Windtightness	650 Pa

SUPPLY > AK80

Compact acoustic window vent

(this product is not available in the UK)

Introduction

The AK80 is a thermally broken acoustic vent with a pleasing compact design. Four different types are developed and according to the type, a different airflow and sound reduction is defined. The AK80 is available for installation on glass, at transom or overframe. The AK80 is applicable on all types of window frames: aluminium, timber and uPVC.

Material

- Inside and outside profile: aluminium AlMgSi 0.5 (according to EN 12020-2)
- Finishing: satin anodised or powdercoated in any RAL colour (dual colour possible)
- Endcaps in ASA polymer type Luran S (colourfast, weather- and UV-resistant)
- Endcaps are available in black, grey or white but also available in other colours upon request
- Sound-reducing material: absorbent foam

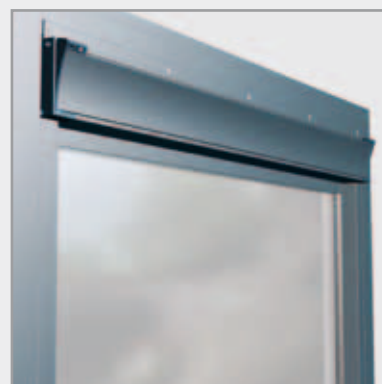

Dimensions

Glass reduction: 80 mm

Height: 83 mm

Glass thickness: variable between 22 and 42 mm

Controls

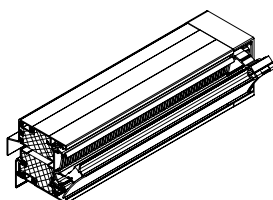

Manual control

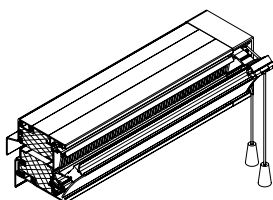

Cord control

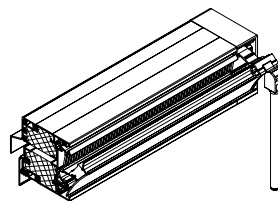

Rod control
(hook-up)
nr. 134

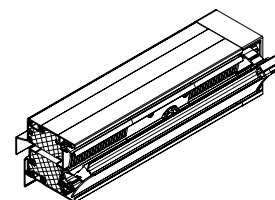

Motor control

Assembly

Developed for fabrication from bar lengths (6000 mm) or made to measure (max. 2000 mm)

Cut ventilator to size from a bar length, fix endcaps (1 L + 1 R)

Overall dimension of the ventilator (T) = extrusion length (Z) + (2x endcaps (EC))

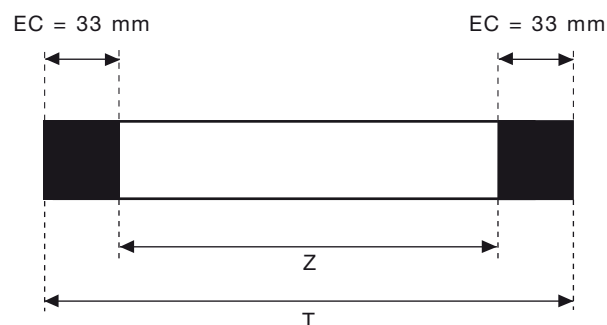

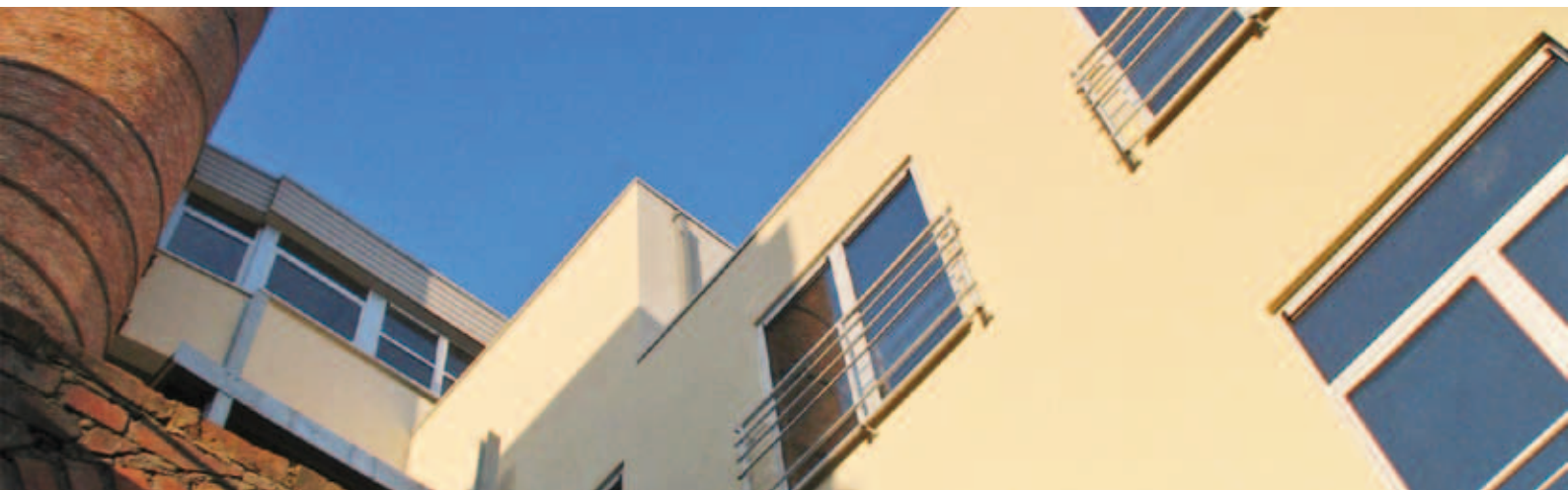

Section details

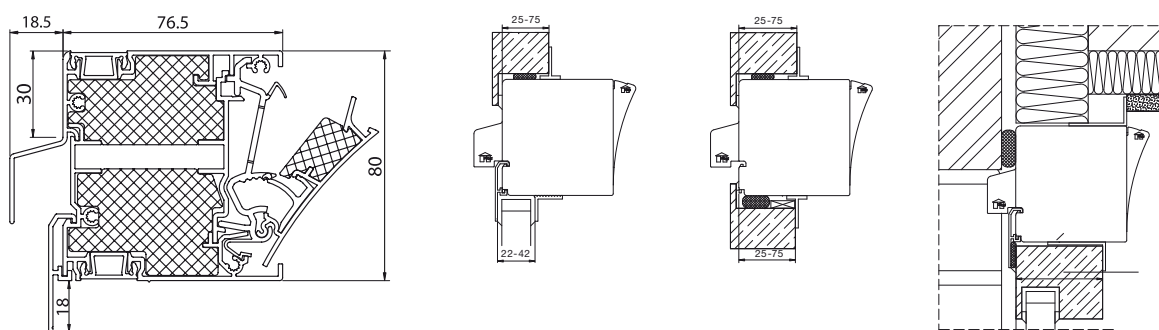

Technical specifications

	AK80/1	AK80/2	AK80/3	AK80/4
AIRFLOW				
2 Pa	5,9 m ³ /h/m	9,0 m ³ /h/m	10,4 m ³ /h/m	34,9 m ³ /h/m
2 Pa	1,6 l/s/m	2,5 l/s/m	2,9 l/s/m	9,7 l/s/m
1 Pa	1,2 l/s/m	1,7 l/s/m	2,0 l/s/m	6,9 l/s/m
Equivalent area	1488 mm ² /m	2163 mm ² /m	2545 mm ² /m	8780 mm ² /m
COMFORT				
Sound reduction D _{n,e,w} (C;C _{tr})	(EN ISO 140-10, EN ISO 717-1)			
- in open position	47 (0;-3) dB	44 (-1;-4) dB	41 (-1;-3) dB	33 (-1;-2) dB
- in closed position	51 (-1;-3) dB	n.p.d.		
Self regulating	no			
TECHNICAL CHARACTERISTICS				
	(EN 13141-1)			
U-value	2,1 W/m ² K			
Watertightness (closed position)	650 Pa			
Windtightness	650 Pa			

SUPPLY > AK80 GL

Compact acoustic glazed-in window vent

(this product is not available in the UK)

Introduction

The AK80 GL is a thermally broken acoustic vent with a pleasing compact design. Four different types are developed and according to each type a different airflow and sound absorption is defined. The AK80 GL is available for installation on glass or at transom. The AK80 GL is applicable on all types of window frames : aluminium, timber and uPVC.

Material

- Inside and outside profile: aluminium AlMgSi 0.5 (according to EN12020-2)
- Finishing: satin anodised or powdercoated in any RAL or Syntha Pulvin® colour (dual colour possible)
- Endcaps in ASA polymer type Luran S (colourfast, weather- and UV-resistant)
- Endcaps are available in black, white, grey but also available in other colours upon request.
- Sound-reducing material: absorbent foam

Dimensions

Glass reduction: 108 mm

Height: 123 mm

Glass thickness: 20, 24, 28, 32 & 36 mm

Controls

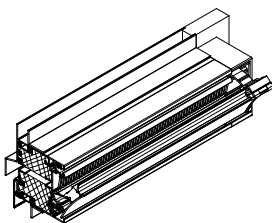

Manual control

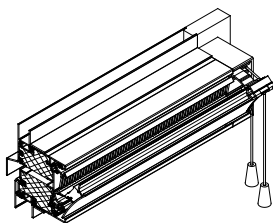

Cord control

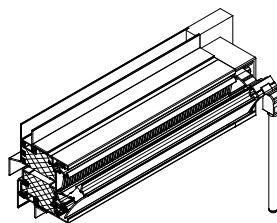

Rod control
(hook-up)
nr. 134

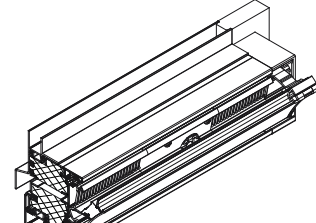

Motor control

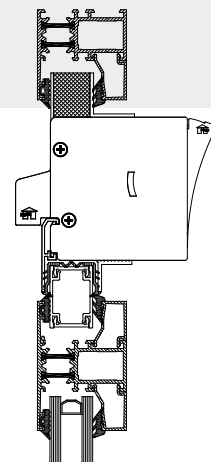
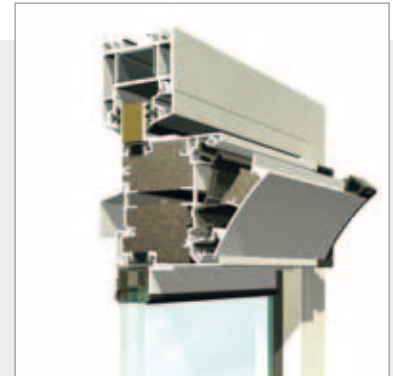

Assembly

Developed for fabrication from bar lengths (6000mm) or made to measure (max. 2000 mm).

Cut ventilator to size from a bar length, fix endcaps (1L+1R).

Overall dimension of the ventilator (T) = extrusion length (Z) + (2x endcaps (EC)).

We advise the use of glazing gasket RENSON® nr 039 or nr 034 (20-28mm) and nr 029 (28-36 mm) for installation.

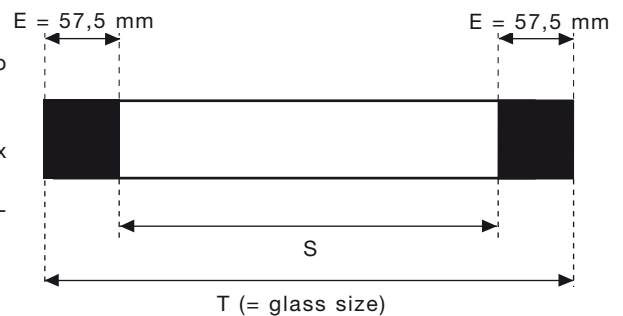



Section details

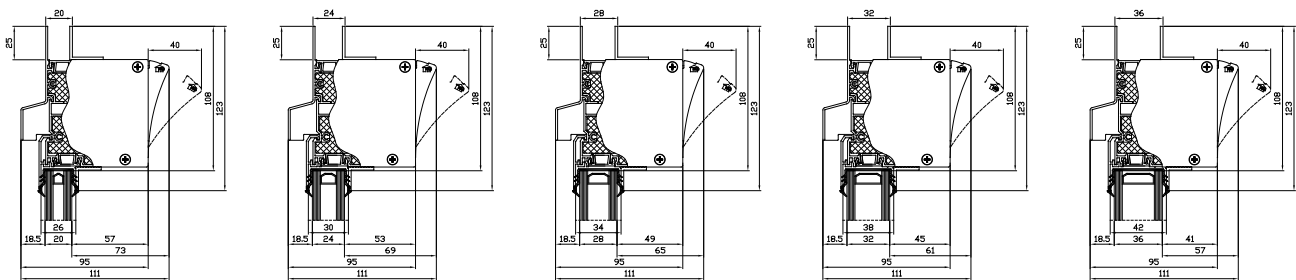

Technical specifications

	AK80 GL-1	AK80 GL-2	AK80 GL-3	AK80 GL-4
AIRFLOW				
2 Pa	5,9 m ³ /h/m	9,0 m ³ /h/m	10,4 m ³ /h/m	34,9 m ³ /h/m
2 Pa	1,6 l/s/m	2,5 l/s/m	2,9 l/s/m	9,7 l/s/m
1 Pa	1,2 l/s/m	1,7 l/s/m	2,0 l/s/m	6,9 l/s/m
Equivalent area	1488 mm ² /m	2163 mm ² /m	2545 mm ² /m	8780 mm ² /m
COMFORT				
Sound reduction D _{n,e,w} (C;C _{tr})	(EN ISO 140-10, EN ISO 717-1)			
- in open position	47 (0;-3) dB	44 (-1;-4) dB	41 (-1;-3) dB	33 (-1;-2) dB
- in closed position	51 (-1;-3) dB	n.p.d.		
Self regulating	no			
TECHNICAL CHARACTERISTICS				
	(EN 13141-1)			
U-value	2,1 W/m ² K			
Watertightness (closed position)	650 Pa			
Windtightness	650 Pa			

SUPPLY > THK90 AK

Glazed-in flapvent with acoustic hood

Introduction

Aluminium thermally broken flapvent with an acoustic hood for all types of windows (aluminium, timber or uPVC).

The THK90 AK has an external hood for excellent weather protection, a sound reducing material is installed in this hood. The THK90 AK is aesthetically similar to the THK90 and the AR90 (see page 54).

Material

- Inside and outside profile: aluminium AlMgSi 0.5 (according to EN 12020-2)
- Finishing: satin anodised or powdercoated in any RAL or Syntha Pulvin® colour (dual colour possible)
- Endcaps in ASA polymer type Luran S (colourfast, weather- and UV-resistant)
- Endcaps are in black or white but also available in other colours upon request.
- Sound-reducing material: absorbent foam

Dimensions

Glass reduction: 90 mm

Height: 105 mm

Glass thickness: 20, 24 & 28 mm

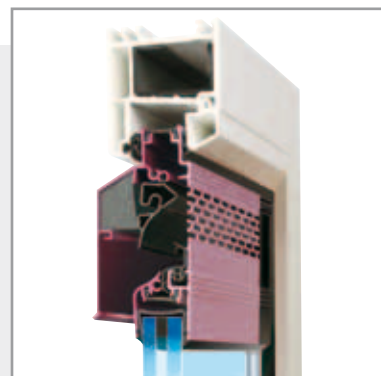

Controls

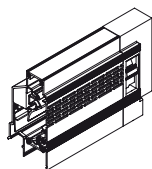

Manual control

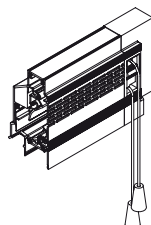

Cord control

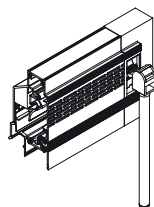

Rod control
(hook-up)
nr. 134

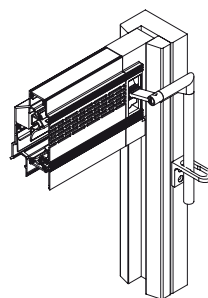

Rod control
(with transmission)
nr. 135

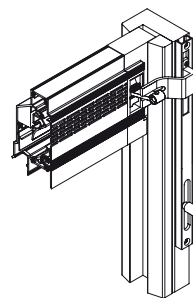

Rod control
(with sliding knob)
nr. 136

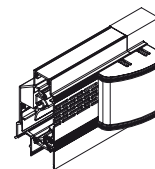

Motor control
width 70 mm
height 63 mm
depth 70 mm

Assembly

Developed for fabrication from bar lengths (6000 mm) or made to measure (max. 2500 mm),

Cut ventilator to size from a bar length, fix endcaps (1 L + 1 R).

We advise the use of glazing gasket RENSON® nr 039 or nr 034 (20-28 mm) for installation.

Overall dimension of the ventilator (T) = extrusion length (Z) + (2x endcaps (EC)).

EC = 43 mm

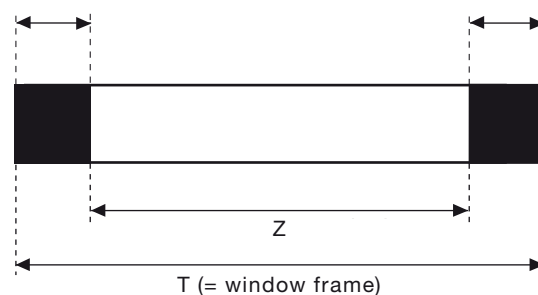



Section details

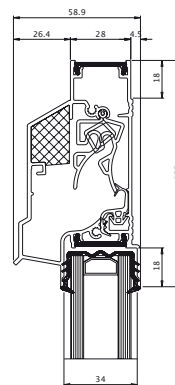
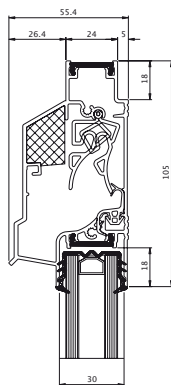
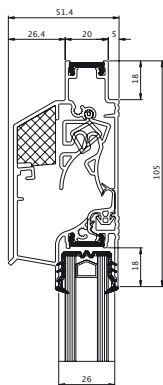

Technical specifications

	THK90 AK
AIRFLOW	
2 Pa	57,9 m ³ /h/m
2 Pa	16,1 l/s/m
1 Pa	11,6 l/s/m
Equivalent area	14736 mm ² /m
COMFORT	
Sound reduction $D_{n,e,w}$ (C;C _{tr})	(EN ISO 140-10, EN ISO 717-1)
- in open position	29 (0;-1) dB
- in closed position	45 (0;-2) dB
Self regulating	no
TECHNICAL CHARACTERISTICS	
U-value	3,9 W/m ² K
Watertightness (closed position)	650 Pa
Windtightness	650 Pa

SUPPLY > Screenvent® Mistral AK

Combination of sound absorbing and comfortable ventilation, an insectmesh and a windtight sunprotecting screen

Introduction

RENSON® has developed the Screenvent® Mistral AK in order to improve the following aspects of living and working comfort:

- Physical comfort; fresh and healthy air without draughts
- Thermal comfort; up to 90% reflection of solar heat
- Visual comfort; daylight control, no reflections, the outside view is not obstructed
- Acoustic comfort; up to 34 dB sound reduction in open position

Thanks to a special zip system in the side guides, the screen is held securely in every position. Therefore rattling or ripped screens belong to the past. Each screen has a bottom rail provided with a rubber seal to close perfectly with the threshold.

Very good acoustic performances are achieved thanks to a sound absorbing foam.

The Screenvent® Mistral AK is installed on top of the window frame and mainly hidden by the facade. This integrated solution for self regulating (P3) ventilation and sunprotection contributes to lower energy costs. The screen is easy to remove as is the inner profile for cleaning purposes. With this combination of comfortable ventilation and windtight sunprotection secure ventilation with closed windows is offered; insect-, burglar-, and wheatherproof.

For more detailed information about window ventilators and the Screenvent® series in general, ask your copy of our catalogues 'Window ventilators' and 'Screen Fabric Technical Brochure'

Concept

1. Easily removable glass fibre screen
2. Removable, thermally insulated inner profile with sound absorbing foam
3. Ventilation control by means of 5 stepped settings
4. Self regulating flap controlling the airflow and minimizing draught
5. Wind resistant sliding system

Applications

- On all types of windows: aluminium, timber, uPVC
- For new buildings as well as for renovation
- For residential dwellings as well as hospitals, offices, schools and many other commercial applications.

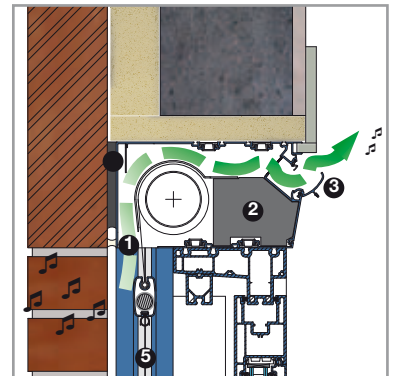

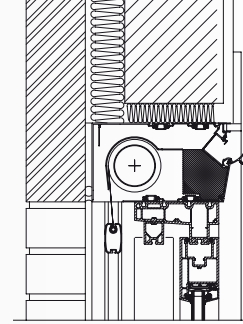
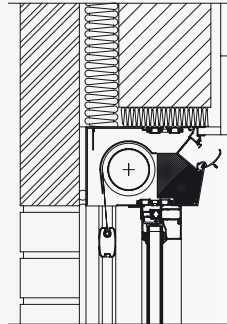

Technical specifications

Screenvent® Mistral AK (depending on the width of the windowframe)	Medium	Large
AIRFLOW		
2 Pa	52,0 m ³ /h/m	50,0 m ³ /h/m
2 Pa	14,4 l/s/m	13,9 l/s/m
1 Pa	10,2 l/s/m	9,8 l/s/m
Equivalent area	8200 mm ² /m	8200 mm ² /m
COMFORT		
Sound reduction D _{n,e,w} (C;C _{tr})	(EN ISO 140-10, EN ISO 717-1)	
- in open position	30 (0;-1) dB	
- in closed position	37 (-1;-3) dB	
Self regulating	yes (class P3)	
TECHNICAL CHARACTERISTICS		
U-value	4,1 W/m ² K	4,0 W/m ² K
Watertightness (closed position)	650 Pa	
Windtightness	650 Pa	
DIMENSIONS		
Box height	120 mm	
Box depth	170 mm	200 mm
Fitted for windowframe width	76-105 mm	106-135 mm
Maximum length in one part	3000 mm	
Maximum screen height	2800 mm	
CONTROLS		
Ventilation	manual, cord, rod, motor	
Sunprotection	manual rod, removable rod, motor (remote control, switch), weather station	

SUPPLY > Slotvents 771AK

Acoustic slotvents

Introduction

771AK, self-regulating acoustic exterior slotvent

This unit is mounted on the outside of all types of window frames.

The punched profile acts as an insect screen.

The self-regulating function is provided by a flap which reacts automatically to variations in pressure, thereby avoiding draughts. The acoustic function is provided by isophononic foam which decreases sound by 36 to 38 dB according to flow rates.

686N, interior slotvent

This canopy is mounted on the inside of all types of window and deflects air upwards for improved comfort.

788P, permanent open interior slotvent

Permanently open tipvent is installed on the interior, is no more than 9 mm in depth and deflects air upwards for improved comfort.

787AK, acoustic interior slotvent

Internal tipvent with acoustic foam, no more than 9 mm in depth with directional airflow upwards.

Material

- Profile: aluminium AlMgSi 0.5 (according to EN12020-2)
- Finishing: satin anodised or powdercoated in any RAL or Syntha Pulvin® colour
- Endcaps in ASA polymer type Luran S (colourfast, weather- and UV-resistant)
- Endcaps are available in black or white, the endcaps for the 771AK are also available in other colours upon request

Dimensions

	771AK/2	686N/3	788P/2	787AK/2
HEIGHT	52 mm	19 mm	34 mm	34 mm
LENGTH	415 mm	475 mm	375 mm	375 mm

Technical specifications

	771AK/2 + 686N/3	771AK/2 + 788P/2	771AK/2 + 787AK/2
Slotsize (mm)	(172x12) + 20 + (172x12)	(172x12) + 10 + (172x12)	(172x12) + 10 + (172x12)
AIRFLOW			
2 Pa	12,5 m ³ /h	13,9 m ³ /h	13,9 m ³ /h
1 Pa	2,4 m ³ /h	2,7 m ³ /h	2,7 m ³ /h
Equivalent Area	3116 mm ²	3471 mm ²	3471 mm ²
COMFORT			
Sound reduction $D_{n,e,w} (C; C_{tr})$			
- in open position	37 (0;-1) dB	40 (-1;-2) dB	40 (-1;-2) dB



Section details

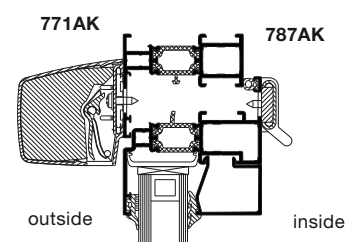
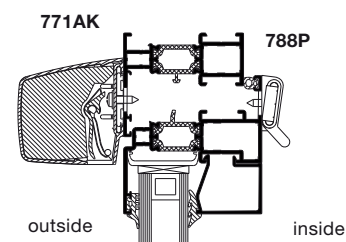
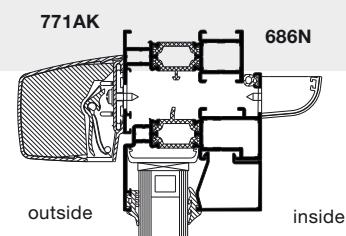

Slotvents 470/30

Acoustic slotvents



470/30



471

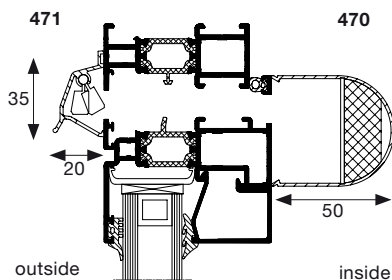

Introduction

470/30, interior sound-absorbing box

This unit is mounted on the inside of the window and is suited to all types of window frames. The punched profile in the endcaps acts as an insect screen. The isophonic foam on the inside decreases sound by 39 dB.

471, self-regulating exterior slotvent

This unit is mounted on the outside of the window and is suited for all types of window frames.

The punched profile acts as an insect screen. The self-regulating function is provided by PVC elements which pivot under wind pressure, thereby maintaining the nominal airflow.

Material

- Profile: aluminium AlMgSi 0.5 (according to EN12020-2)
- Finishing: satin anodised or powdercoated in any RAL or Syntha Pulvin® colour
- Endcaps in ASA polymer type Luran S (colourfast, weather- and UV-resistant)
- Endcaps are available in black or white

Dimensions

	471/1	471/2	471/3	470/30
HEIGHT	35 mm	35 mm	35 mm	45 mm
LENGTH	275 mm	375 mm	475 mm	400 mm

Technical specifications

	471/1 + 470/30	471/2 + 470/30	471/3 + 470/30
Slotsize (mm)	250 x 12	250 x 12	(172x12) + 20 + (172x12)
AIRFLOW			
2 Pa	4,1 m ³ /h	4,5 m ³ /h	9,9 m ³ /h
1 Pa	0,8 m ³ /h	0,9 m ³ /h	1,9 m ³ /h
Equivalent Area	1025 mm ²	1125 mm ²	2482 mm ²
COMFORT			
Sound reduction $D_{n,e,w}$ ($C;C_{tr}$)			
- in open position	39 (0;-1) dB	40 (-1;-1) dB	40 (-1;-1) dB

TRANSIT > Silendo®

Acoustic door grille for residential sector

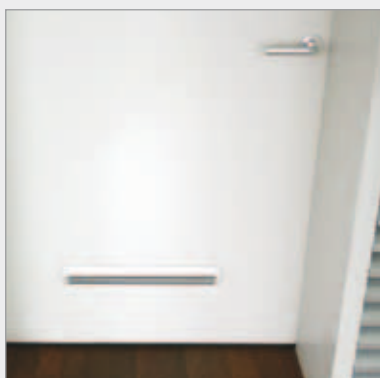

Introduction

The RENSON® Silendo® acoustic door grille is suited for interior doors of residential buildings (for example, toilet doors). The airflow is diverted in the form of a chicane. The Silendo® is fixed invisibly.

Material

- Made from aluminium sections: AlMgSi 0.5 (according to EN 12020-2)
- Finishing: satin anodised or powdercoated in any RAL or Syntha Pulvin® colour (dual colour possible)
- Sound reducing material: synthetic foam
- Endcaps: type Luran S ASA polymer (colourfast, weatherproof and UV-resistant)
- Endcaps: available in grey, black or white; can be repainted by the customer

Available models

- The Silendo® is available in a standard 425 x 48 mm size in the following standard colours: RAL 9010 (with matching white end caps), RAL 8019 (black end caps) and natural colour (grey end caps).
- Other lengths and colours available on request.

Dimensions

- Length: 425 mm
- Height: 48 mm
- Door thickness: 37 to 43 mm

Cross-sections

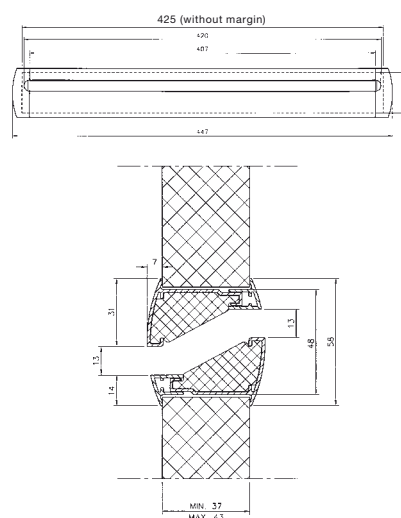

Technical specifications

		Silendo®
AIRFLOW		(EN 13141-1)
	Q at 2 Pa	25,1 m³/h
COMFORT		(EN ISO 140-10, EN ISO 717-1)
	Sound reduction in open position $D_{n,e,w}$ ($C;C_{tr}$)	32 (0;-2) dB
TECHNICAL DATA		
	Visual free area	27%
	Physical free area	27%

468AK/2

Acoustic door grille



468AK/2 – front view



468AK/2 – rear view

Introduction

The RENSON® 468 AK/2 acoustic door grille is mainly used in interior doors of hospitals, schools, sports facility changing rooms, etc. The airflow is diverted in the form of a labyrinth. The 468 AK/2 grille is fixed using the screws provided.

Material

- Made from aluminium sections: AlMgSi 0.5 (according to EN 12020-2)
- Finishing: satin anodised or powdercoated in any RAL or Syntha Pulvin® colour
- Sound reducing material: synthetic foam

Available models

- The 468 AK/2 is available in RAL 9010 in the following standard sizes: 292 x 193 mm, 382 x 278 mm, 432 x 363 mm and 452 x 448 mm.
- Other sizes and colours available on request.

Technical specifications

468 AK/2		
AIRFLOW	Airflow (EN 13030)	Comfort - $D_{n,e,w}$ (C;C _{tr})
Q at 2 Pa - grille 292 x 193 mm	25 m ³ /h	30 (-1;-2) dB
Q at 2 Pa - grille 382 x 278 mm	50 m ³ /h	28 (-1;-2) dB
Q at 2 Pa - grille 432 x 363 mm	75 m ³ /h	26 (-1;-2) dB
Q at 2 Pa - grille 452 x 448 mm	100 m ³ /h	25 (-1;-2) dB
COMFORT (EN ISO 140-10, EN ISO717-1)		
Sound reduction in open position R_w (C;C _{tr})	8 (-1;-2) dB	
TECHNICAL DATA		
Visual free area	29%	
Physical free area	29%	

Dimensions

- Minimum dimensions: 200 x 193 mm H
- Maximum dimensions: 788 x 788 mm H
- Fitting dimensions: 7 mm more than the grille dimensions.
- Height in 85 mm steps (blade pitch)
- Door thickness: from 37.5 to 92 mm

Cross-sections

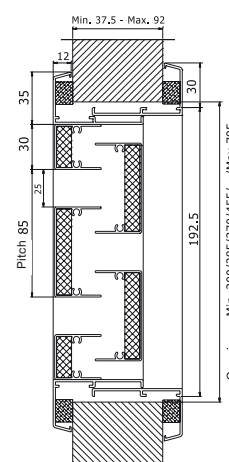

468AK/2

SUPPLY / EXTRACTION > 468AK/1

Interior acoustic wall louvre



468AK/1 – front view



468AK/1 – rear view

Introduction

The RENSON® 468 AK/1 acoustic wall louvre is mainly used in hospitals, schools, sports facility changing rooms, etc. The airflow is diverted in the form of a labyrinth. Louvre 468 AK/1 is fixed using the brackets provided.

Material

- Made from aluminium sections: AlMgSi 0.5 (according to EN 12020-2)
- Finishing: satin anodised or powdercoated in any RAL or Syntha Pulvin® colour
- Sound reducing material: synthetic foam

Available models

- The 468 AK/1 is always made to measure, up to a maximum size of 776 x 776 mm.

Technical specifications

Dimensions

- Minimum dimensions: 200 x 181 mm H
- Maximum dimensions: 776 x 776 mm H
- Fitting dimensions: 7 mm more than the louvre dimensions.
- Height in 85 mm steps (blade pitch)
- Depth to fit: 48 mm
- Flange size: 30 mm

Cross-sections

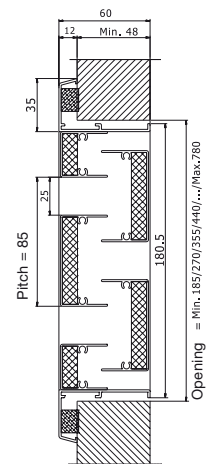

468AK/1

468 AK/1		
AIRFLOW	Airflow (EN 13030)	Comfort - $D_{n,e,w}$ ($C;C_{tr}$)
Q at 2 Pa - grille 292 x 193 mm	25 m ³ /h	30 (-1;-2) dB
Q at 2 Pa - grille 382 x 278 mm	50 m ³ /h	28 (-1;-2) dB
Q at 2 Pa - grille 432 x 363 mm	75 m ³ /h	26 (-1;-2) dB
Q at 2 Pa - grille 452 x 448 mm	100 m ³ /h	25 (-1;-2) dB
COMFORT	(EN ISO 140-10, EN ISO717-1)	
Sound reduction in open position R_w ($C;C_{tr}$)	8 (-1;-2) dB	
TECHNICAL DATA		
Visual free area	29%	
Physical free area	29%	

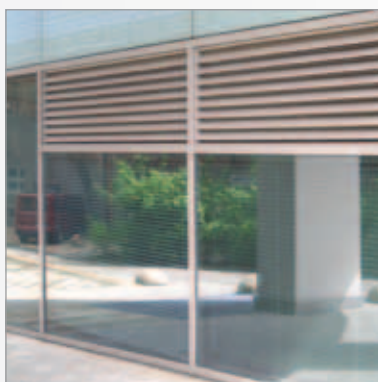

Introduction

The RENSON® 445/86 acoustic louvre is mainly used in ventilation, cooling and heating systems and car parks to absorb industrial noise. Louvre 445/86 is fixed using the brackets provided.

Material

- Made from aluminium sections: AlMgSi 0.5 (according to EN 12020-2)
- Finishing: satin or bronze anodised or powdercoated in any RAL or Syntha Pulvin® colour
- Sound reducing material: non-combustible mineral wool
- Stainless steel 304 mesh (6 x 6 mm) or insect screen (2.3 x 2.3 mm) on request

Available models

- The 445/86 is always made to measure.
- Optional water channel and drainage profile available on request.
- The 445/86 can also be ordered with a flangeless frame* or for glazing into a window profile** (for 24 mm thick glass).
- For louvres larger than approx. 3 m², a reinforcing back-structure is required.

Dimensions

- Minimum dimensions: 300 x 300 mm H
- Height in 60 mm steps (blade pitch)
- Depth to fit: 81.5 mm
- Flange size: 50 mm

Cross-sections

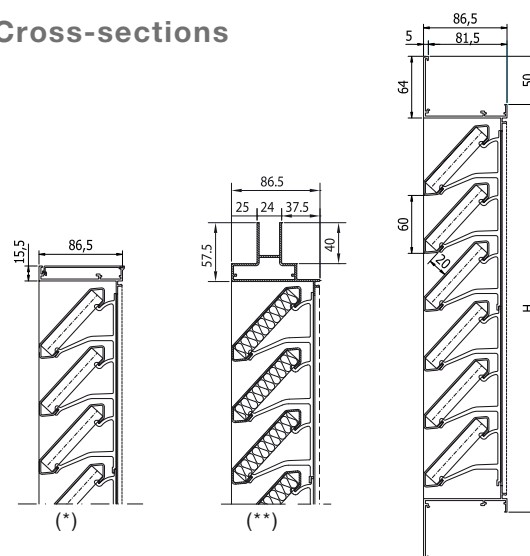

Technical specifications

		445/86
AIRFLOW		(EN 13030)
	K-factor (supply)	9,22
	K-factor (discharge)	13,29
	C _e coefficient	0,329
	C _d coefficient	0,274
COMFORT		(EN ISO 140-10, EN ISO 717-1)
	Sound reduction in open position R _w (C;C _{tr})	6 (-1;-2) dB
TECHNICAL DATA		
	Visual free area	74%
	Physical free area	34%

SUPPLY / EXTRACTION > 446/150

Acoustic wall louvre



Introduction

The RENSON® 446/150 wall louvre is mainly used in ventilation, cooling and heating systems and car parks to absorb industrial noise. The bottom part consists of a perforated plate for soundproofing.

Material

- Made from aluminium sections: AlMgSi 0.5 (according to EN 12020-2)
- Finishing: satin anodised or powdercoated in any RAL or Syntha Pulvin® colour
- Sound reducing material: non-combustible mineral wool
- Stainless steel 304 mesh (6 x 6 mm)

Available models

- The 446/150 is always made to measure.
- For louvres larger than approx. 3 m², a reinforcing backstructure is required.

Dimensions

- Minimum dimensions: 300 x 300 mm H
- Height in 150 mm steps (blade pitch)
- Depth to fit: 150 mm
- Flange size: 40 mm

Cross-sections

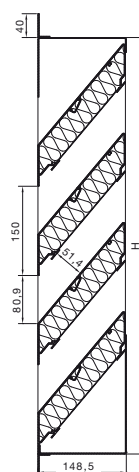

Technical specifications

	446/150
AIRFLOW	(EN 13030)
K-factor (supply)	14,24
K-factor (discharge)	14,24
C _e coefficient	0,265
C _d coefficient	0,265
COMFORT	(EN ISO 140-10, EN ISO 717-1)
Sound reduction in open position R _w (C;C _{tr})	11 (-1;-2) dB
TECHNICAL DATA	
Visual free area	77%
Physical free area	35%

445/300

Double acoustic wall louvre



Introduction

The RENSON® 445/300 wall louvre is mainly used in ventilation, cooling and heating systems and car parks to absorb industrial noise.

The bottom part consists of a perforated plate for sound-proofing.

Material

- Made from aluminium sections: AlMgSi 0.5 (according to EN 12020-2)
- Finishing: powdercoated in any RAL or Syntha Pulvin® colour
- Sound reducing material: non-combustible mineral wool
- Stainless steel 304 mesh (6 x 6 mm)

Available models

- The 445/300 is always made to measure.
- For louvres larger than approx. 3 m², a reinforcing backstructure is required.

Dimensions

Minimum dimensions: 300 x 300 mm H

Height in 150 mm steps (blade pitch)

Depth to fit: 300 mm

Flange size: 40 mm

Cross-sections

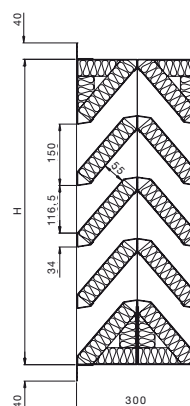

Technical specifications

	445/300
AIRFLOW	(EN 13030)
K-factor (supply)	28,60
K-factor (discharge)	28,60
C _e coefficient	0,187
C _d coefficient	0,187
COMFORT	(EN ISO 140-10, EN ISO 717-1)
Sound reduction in open position R _w (C;C _{tr})	16 (-1;-3) dB
TECHNICAL DATA	
Visual free area	77%
Physical free area	35%

SUPPLY / EXTRACTION > 445B

Acoustic silencer for louvres

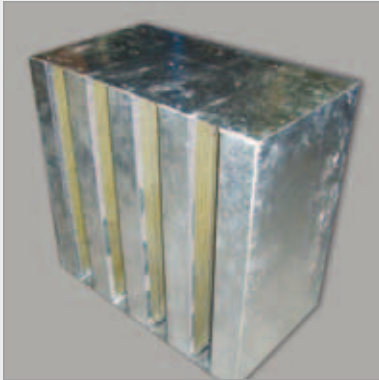

Introduction

The RENSON® 445B acoustic silencer is available in three depths: 425, 725 and 1025 mm. On the outside, a louvre (type 411, 421, 425, 451, etc., depending on the required airflow) is fitted for an aesthetic appearance and protection against rain.

The acoustic silencer is mainly used in installations requiring a high degree of sound reducing.

Material

- Galvanised steel plate.
- Louvre finish in aluminium: satin anodised or powder-coated in any RAL or Syntha Pulvin® colour (refer to louvres catalogue)
- Sound reducing material: non-combustible mineral wool

Available models

- Acoustic silencers 445B are always made to measure.

Dimensions

- Depth: 425 mm, 725 mm or 1025 mm.

Cross-sections

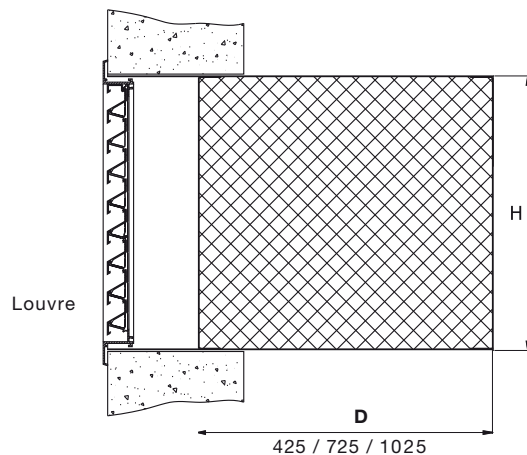

Technical specifications

		445B / 1025
AIRFLOW		(EN 13030)
K-factor (supply)		Subject to the louvre used on the outside
K-factor (discharge)		
C _s coefficient		
C _d coefficient		
COMFORT		(EN ISO 140-10, EN ISO 717-1)
Sound reduction in open position R _w (C;C _{tr})		19 (-1;-4) dB
TECHNICAL DATA		
Visual free area		Subject to the louvre used on the outside
Physical free area		

Linius® L.060AC

Acoustic Continuous Louvre System



Introduction

The L.060AC acoustic Linius® blade was developed to provide an aesthetic solution for continuous louvre applications with large noise-reducing requirements. The system is mainly applied in ventilation systems, cooling and heating systems, car parks and to subdue sources of industrial noise. A perforated sound reducing sheet is provided at the bottom.

Material

- Blades, mullions and blade supports: aluminium AlMgSi 0.5 (according to EN 12020-2)
- Finishing: satin anodised or powdercoated in any RAL or Syntha Pulvin® colour
- Sound reducing material: non combustible mineral wool
- Mesh (optional): stainless steel 304 18/8 6 x 6 mm (attached to the back of the support structure).

Available models

All Linius® Continuous Louvre Systems are made to customer specifications.

Dimensions

Maximum blade length: 6000 mm

Pitch: 60 mm

Max. unsupported span between two mullions: 1700 mm

Section details

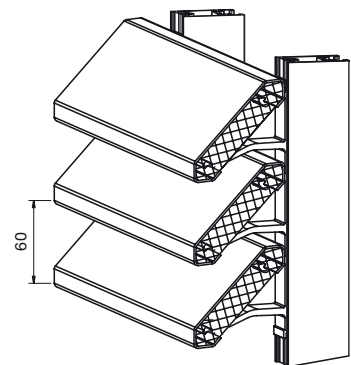
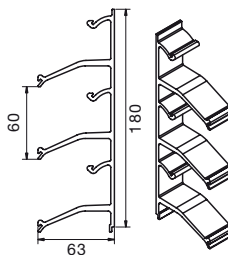
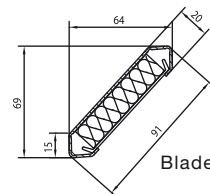

Technical specifications

	L.060AC
AIRFLOW	
K-factor (supply)	9,22
K-factor (discharge)	13,29
C _e coefficient	0,329
C _d coefficient	0,274
COMFORT	
Sound reduction in open position R _w (C;C _{tr})	6 (-1;-2) dB
TECHNICAL DATA	
Visual free area	74%
Physical free area	34%

SUPPLY / EXTRACTION > Linius® L.150ACS

Acoustic Continuous Louvre System



Introduction

The L.150ACS acoustic Linius® blade was developed to provide an aesthetic solution for continuous louvre applications with large noise-reducing requirements. The system is mainly applied in ventilation systems, cooling and heating systems, car parks and to subdue sources of industrial noise. A perforated sound reducing sheet is provided at the bottom.

Material

- Blades, mullions and blade supports: aluminium AlMgSi 0.5 (according to EN 12020-2)
- Finishing: satin anodised or powdercoated in any RAL or Syntha Pulvin® colour
- Sound reducing material: non combustible mineral wool
- Mesh (optional): stainless steel 304 18/8 6 x 6 mm (attached to the back of the support structure).

Available models

All Linius® Continuous Louvre Systems are made to customer specifications.

Dimensions

Maximum blade length: 6000 mm

Pitch: 150 mm

Max. unsupported span between two mullions: 2800 mm

Section details

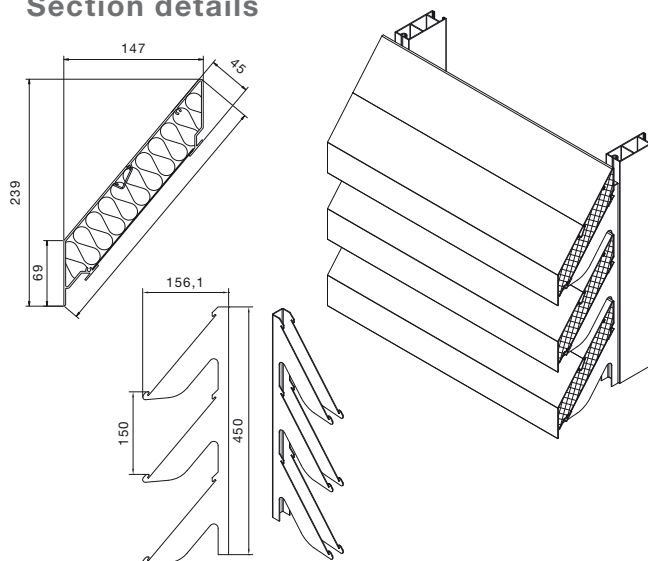

Technical specifications

		L.150ACS
AIRFLOW		
	K-factor (supply)	27,4
	K-factor (discharge)	27,1
	C _e coefficient	0,191
	C _d coefficient	0,192
COMFORT		
	Sound reduction in open position R _w (C;C _{tr})	11 (-1;-2) dB
TECHNICAL DATA		
	Visual free area	54%
	Physical free area	34%

Linius® L.150ACL

Acoustic Continuous Louvre System

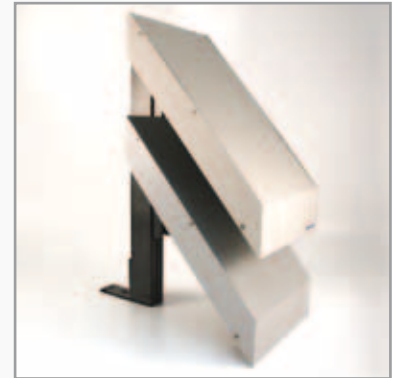

Introduction

The L.150ACL acoustic Linius® blade was developed to provide an aesthetic solution for continuous louvre applications with large sound reducing requirements. The system is mainly applied in ventilation systems, cooling and heating systems, car parks and to subdue sources of industrial noise. A perforated noise-damping sheet is provided at the bottom.

Material

- Blades, mullions and blade supports: aluminium AlMgSi 0.5 (according to EN 12020-2)
- Finishing: satin anodised or powdercoated in any RAL or Syntha Pulvin® colour
- Sound reducing material: non combustible mineral wool
- Mesh (optional): stainless steel 304 18/8 6 x 6 mm (attached to the back of the support structure).

Available models

All Linius® Continuous Louvre Systems are made to customer specifications.

Dimensions

Maximum blade length: 6000 mm

Pitch: 150 mm

Max. unsupported span between two mullions: 2700 mm

Section details

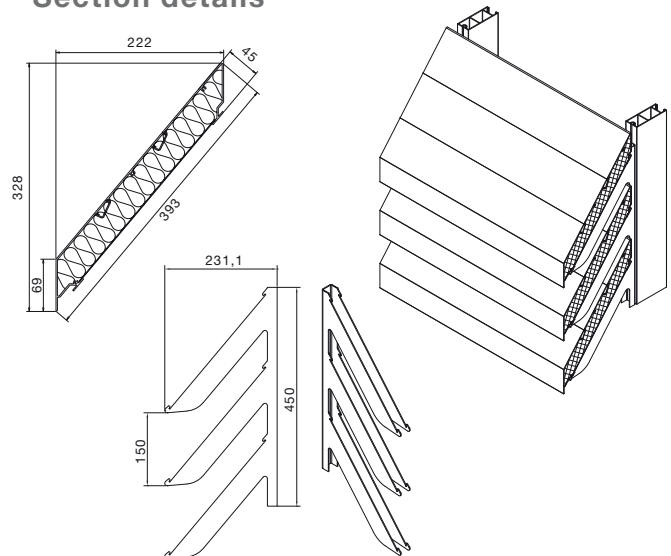

Technical specifications

	L.150 ACL
AIRFLOW	
K-factor (supply)	37,3
K-factor (discharge)	41,9
C _e coefficient	0,164
C _d coefficient	0,154
COMFORT	
Sound reduction in open position R _w (C;C _{tr})	15 (-1;-4) dB
TECHNICAL DATA	
Visual free area	54%
Physical free area	34%

SUPPLY / EXTRACTION > Linius®

Insulating and sound absorbing Continuous Louvre System

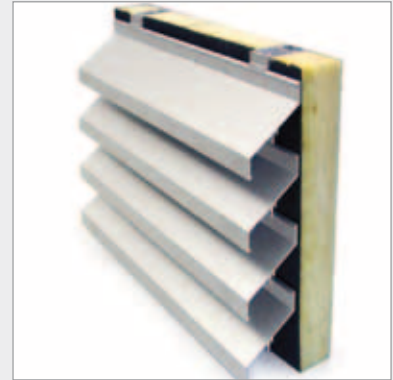

Acoustic wall

Introduction

The RENSON® Linius® Continuous Louvre System can be equipped with a sound-absorbing back wall. This back wall is both thermally insulating and sound-absorbing and can help prevent echoing (e.g. in staircases). Please refer to the RENSON® 'Linius®' brochure for the various available blade types. The insulating material is inserted between the louvre system's support structures, so the 'insulated' louvre system is not any thicker than an ordinary louvre system.

Material

- Frame and blade profiles: aluminium AlMgSi 0.5 (according to EN1202-2)
- Finishing: satin anodised or powdercoated in any RAL or Syntha Pulvin® colour
- Sound reducing material: non combustible mineral wool

Available models

This concept is applicable to almost any type of Linius® series blades. Both Z-blades, such as L.033, and heavy Z-blades, such as L.066, as well as V-blades, such as L.033V, can be equipped with an insulating/sound absorbing back wall.

Technical characteristics

Please refer to the RENSON® Linius® brochure for the technical specifications of the various blades.

Section details

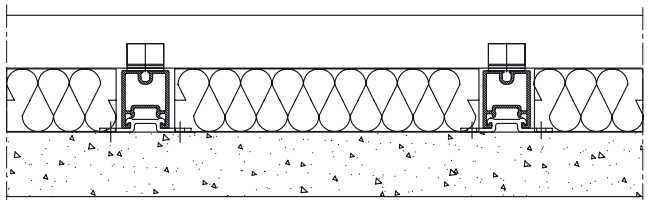
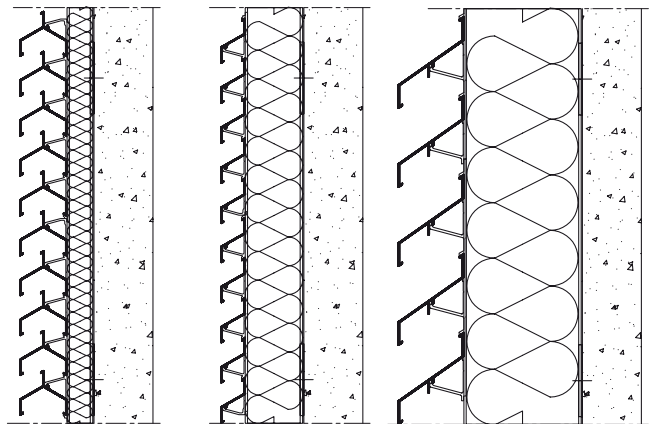

Epilogue

References

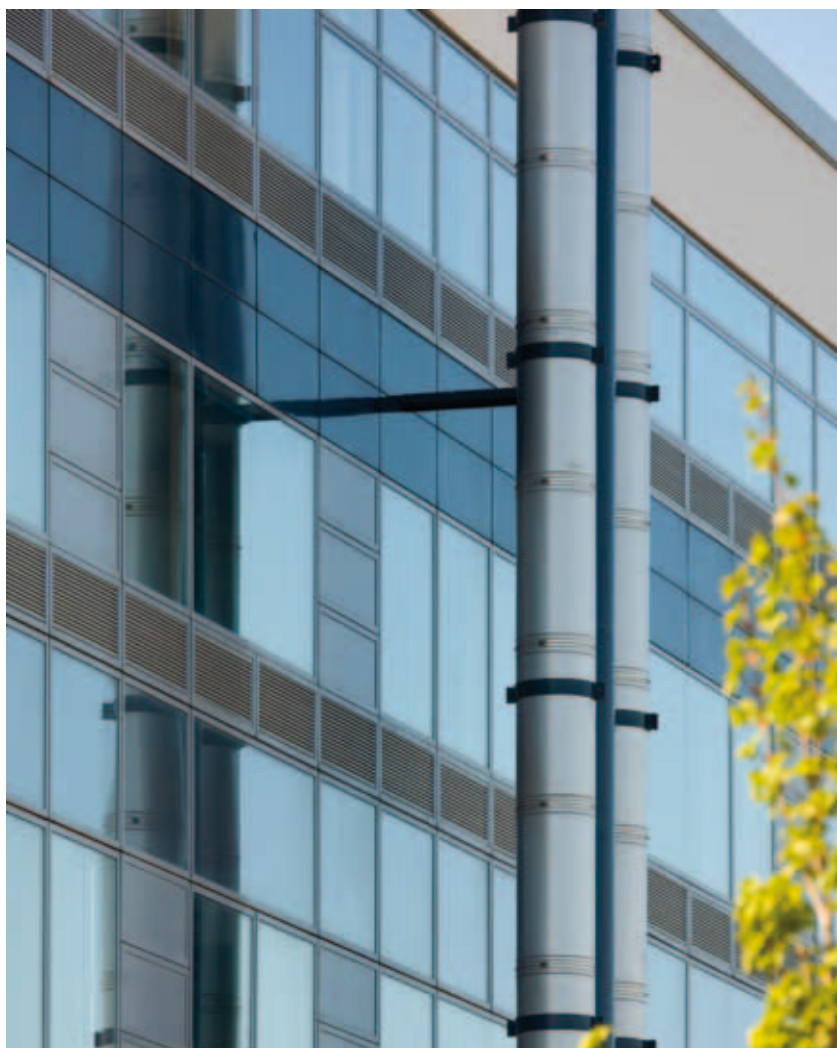
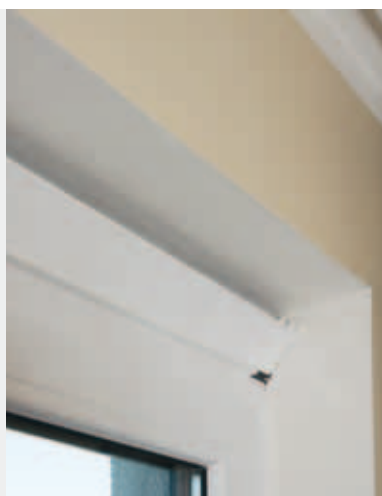



Cherfan Draperies S.A.R.L., Jal El Dib Main Roan, P.O.Box 60-367 Beirut Lebanon

T + 961 4 710061 F + 961 4 719061 E info@creashade.com W www.creashade.com

Canada Branch: Creashade Canada Inc., 505 Industrial, Road Unit B2, Ottawa, Ontario K1G OZ1

T + 1 613 627 3959 M + 1 613 794 0097