



CREASHADE
SUN SHADING SOLUTIONS



Fixscreen®

Fixscreen® 85 | Fixscreen® 100^{EVO}

Fixscreen® 150^{EVO} (F) | Fixscreen® Mono AK



The need for sun protection

A sun-oriented building or one with large windows on the south-side has many benefits. During the autumn, winter and spring, you can enjoy all of the benefits of the incoming rays of sunshine. In the summertime, though, the building can be susceptible to overheating and occupants may experience uncomfortable light refractions.

Structural sun protection systems and screens are used to help protect the building from overheating and to block the sunrays before they hit the glass surfaces. The unwanted heat and the disturbing glare does not get inside. There is no chance of people being blinded or having to deal with unpleasant reflections on the TV or computer monitors, yet you still maintain visual contact with the environment outside. The outdoor view is important and our products respect that.

KYOTO protocol

Many developed countries have now signed the Kyoto protocol. People are becoming more aware of the growing dangers human impact will have on our planet and how it will affect our climate in particular. In order to control these changes and to reduce the Greenhouse Effect, energy consumption must be decreased.

Cooling buildings is a major energy-consuming activity. In order to reduce or in some cases completely eliminate the need for cooling, efficient sun protection can be used.

Several governments have already taken steps related to energy consumption and ventilation.

- Belgium: Regulations concerning Energy Performance & Indoor Climate (EPB)
- Netherlands: Energy Performance Coefficient (EPC)
- France: Règlement Thermique 2012 (RT2012)
- Germany: Energy savings regime
- Great Britain: Approved Document L2 'Conservation of fuel and power in buildings other than dwellings'

table of contents

Introduction	3
Advantages	4
Technical specifications Fixscreen®	5
Product specifications Fixscreen®	8
Product specifications Fixscreen® Mono AK	10
Installation method Fixscreen® 85	13
Installation method Fixscreen® 100 ^{EVO}	14
Installation method Fixscreen® 150 ^{EVO} (F)	16
Installation method Fixscreen® Mono AK	17
Methods of operation	18
Technical possibilities Fixscreen®	20
Technical possibilities Fixscreen® Mono AK	23
Type of fabric	24
Overview top 20 RAL	27
Maintenance	28
Guarantee	28
EC declaration	29

The Fixscreen® was developed by RENSON® Sun protection-Screens and is the first external screen in the world that is truly wind tight.

Thanks to an ingenious zip system, the fabric is wind tight in every position and can be insect-proof in the closed position. It is a simple principle by which the sun-protecting fabric has a special trim with a symmetrical zip which holds the entire structure firmly in the two side channels.

Fixscreen®, the technological performer in terms of comfort and ease of use, can be used in residential, offices and project buildings.

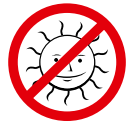

Fixscreen® has a full range of wind-tight screens.

Fixscreen® 85 is developed for dimensions of 2.50 m (width) by 1.80 m (height) (up to max. 4.50 m²). It is possible to join them up to dimensions of 5.00 m (width) by a maximum of 1.80 m (height). This small screen is important for the 'standard window' and the renovation market.

Fixscreen® 100^{EVO} is developed for dimensions up to 4.00 m (width) by 2.70 m (height) or 3.00 m (width) by 3.50 m (height) (up to 10.8 m²). It is possible to join them up to dimensions of 6.00 m (width) by a maximum of 2.70 m (height). **New!** Patented & CE-approved Connect&Go technology

Fixscreen® 150^{EVO} can handle unique dimensions up to 6.00 m width or 6.00 m height (up to 22 m²).

Fixscreen® 150^{EVO} F can be installed in an open construction without a window lying behind. It is developed for dimensions up to 6,00 m (width) and 2,70 m (height), by a maximum of 16,2 m².

Fixscreen® Mono AK helps you to achieve a healthy indoor climate in your home. This new vertical sunprotection will offer you a better visual, thermal and acoustic comfort. This screen is developed for dimensions up to 4,00 m (width) and 2,70 m (height) or 3,00 m (width) and 3,50 m (height) (up to 10,8 m²).

The extensive range of colours of the fabrics and the profiles ensures that the Fixscreen® is in perfect harmony with the architecture of your home or company, which automatically leads to a pleasant living and working environment. All materials used for the Fixscreen® are 100% corrosion-proof. Only stainless steel screws have been used. The aluminium profiles consist of an alloy EN AW-6063 T66. The profiles are available in every possible colour.





- ✓ **A wind-tight screen**

The Fixscreen® is compliant with European standard EN13561 (Wind Resistance class 3). Flapping and torn fabric are a thing of the past.
- ✓ **No wrinkling**

The zip technology guarantees a smooth and wrinkle-free fabric.
- ✓ **Control over light**

Fixscreen® blocks the sunrays before they come into contact with glass surfaces. There is no chance of blinding or unpleasant glare. And you still maintain visual contact with the environment outside. The outdoor view is important and we respect that. Depending on the type of fabric selected, different degrees of translucence are possible.
- ✓ **Control over heat and energy**

Specially designed to protect the building from the sun's energy and to achieve an optimal indoor climate. Structural sun protection and screens helps to avoid overheating by making sure the unwanted heat does not get inside. This can save a lot of money on cooling and air-conditioning during the summer and in the winter can be controlled to let in the optimum amount of light whilst reducing glare. Depending on the type of fabric selected, different degrees of heat-resistance are possible.
- ✓ **Insect-proof**

Intensive ventilation is possible without insects getting a chance to invade your home. There is no opening between the side channel and the screen plus the bottom bar with a darkening strip ensures a seamless connection with the sill.
- ✓ **Silent operation**

We guarantee a bottom bar without the banging noise.
- ✓ **Easy to operate**

Manual or electric operation.
- ✓ **Easy maintenance**

Fixscreen® does not require much maintenance.
- ✓ **Easy installation**

Installation for the window or on the wall (mounting). Also possible on the window with or without roller blind encased with mounting braces (built-in). The open & closed side channels are pre-drilled, which fastens the process of placement (100^{EVO} & 150^{EVO}). The Connect&Go technology is available with the Fixscreen 100^{EVO}, Fixscreen® 150^{EVO} and Fixscreen® Mono Ak. This simplifies the assembly and disassembly of the fabric roller barrel, the motor and the fabric. This new technology also makes it possible to easily secure the headbox.
- ✓ **Large dimensions up to 22 m²**

Fixscreen® 150^{EVO} is suitable for dimensions of 6 m wide or 6 m high (up to 22 m²).
- ✓ **Possibility to couple**

The Fixscreen® 85, the Fixscreen® 100^{EVO} and the Fixscreen® 150^{EVO} can be coupled, this ensures an easy and quick mounting by your carpenter

Wind tested

Wind tunnel testing by the Von Karman Institute for Fluid Dynamics. Wind tunnel test report from the Von Karman Institute (no. EAR0410). Tests carried out up to 150 km/h.

Fixscreen® of 2000 x 2000 mm has no problems in winds up to 120 km/h (see Beaufort scale).



Fixscreen® 120 km/h



Standard screen 30 km/h



The result: the sun-protection fabric must be taken in at wind speeds greater than 80 km/h
Guaranteed up to 80 km/h when closed.

Beaufort scale				
Beaufort	Description	Average speed in m/s	Average speed in km/h	Consequences
0	Calm	< 0,2	< 1	You don't feel the wind. Smoke will rise virtually straight up.
1	Light air	0,3 - 1,4	1 - 5	Wind direction can be read from the smoke plume, but not from the weather vane.
2	Light breeze	1,5 - 3,4	6 - 12	Wind can be felt on the face, leaves rustle, the weather vane moves visibly with the wind.
3	Gentle breeze	3,5 - 5,4	13 - 19	Flags wave and leaves move about constantly
4	Moderate	5,5 - 7,4	20 - 27	Dust blown up causes problems for the eyes. Hair is awry.
5	Fresh breeze	7,5 - 10,4	28 - 37	Bushes rustle, white tops on lakes and canals.
6	Strong breeze	10,5 - 13,4	38 - 48	Umbrellas are difficult to hold on to, large branches sway, power lines hum
7	High wind to near gale	13,5 - 17,4	49 - 62	It is difficult walking against the wind. Trees sway.
8	Gale	17,5 - 20,4	63 - 73	Making headway is very difficult. Small branches break off.
9	Fresh gale	20,5 - 24,4	74 - 87	Chimney tops, roofing tiles and antennas blow away.
10	Whole gale	24,5 - 28,4	88 - 102	Adults blow over. Major damage to buildings.
11	Violent storm	28,5 - 32,4	103 - 117	Major damage to houses and forests.
12	Hurricane	> 32,5	> 118	Destruction

Source: Deutscher Wetterdienst (DWD) - Offenbach

Pressure tests

Destructive test at the WTCB.

The wind resistance of the sun protection system is determined on the basis of a test in a wind tunnel in accordance with NBN EN 1932 version 2001.

The underpressures and overpressures are tested in the wind tunnel with the help of a fan and a system of electrically operated valves to create those pressures.

Durability test report of the WTCB (no. 651 XE823 CAR4139).



335 Pa



Max. 600 Pa

Results

Pressure was increased in steps from 50 Pa up to the limit of 600 Pa.

At pressure of 600 Pa, the zip was pulled from the side channel without tearing.

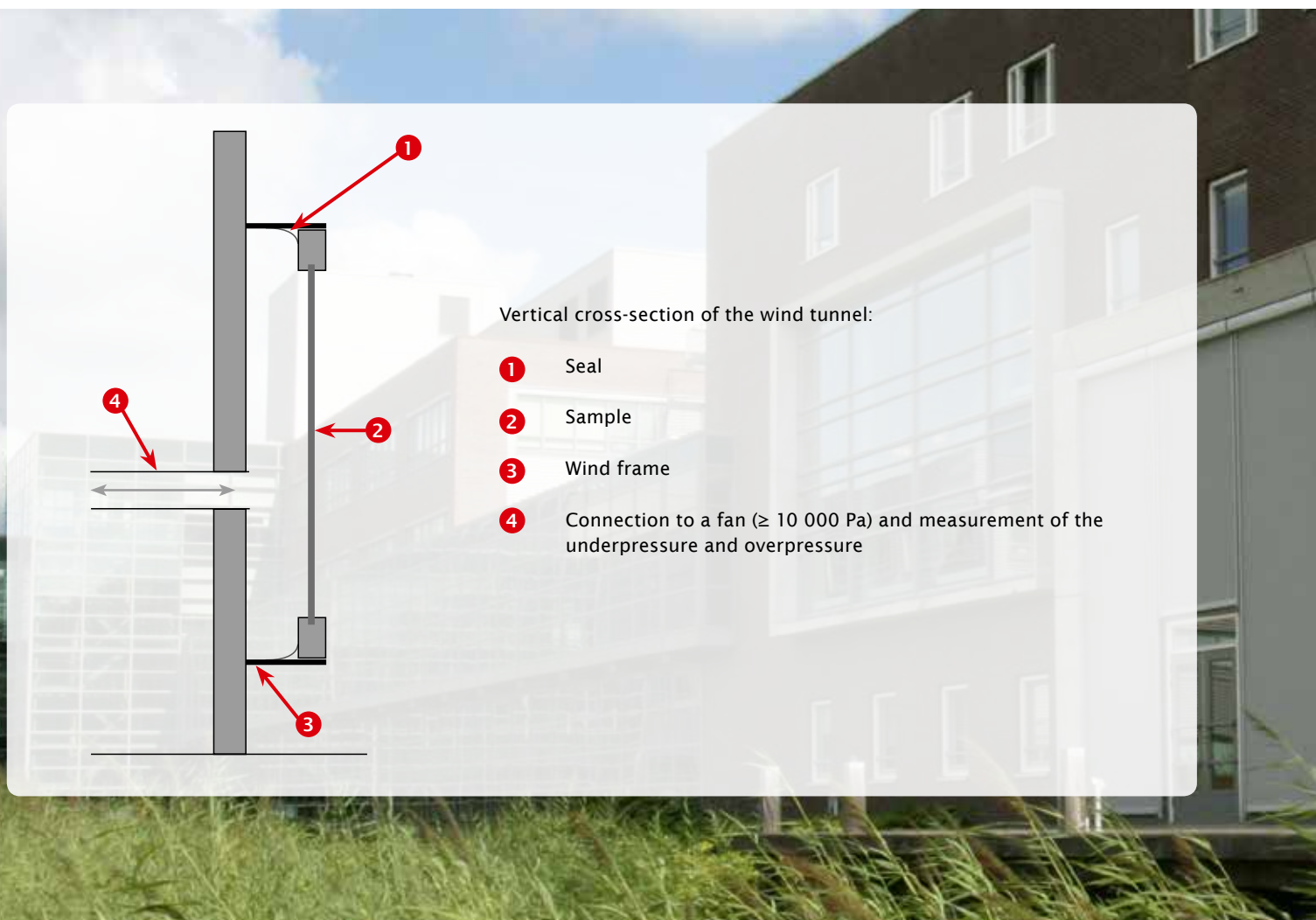

Vertical cross-section of the wind tunnel:

- 1 Seal
- 2 Sample
- 3 Wind frame
- 4 Connection to a fan ($\geq 10\ 000$ Pa) and measurement of the underpressure and overpressure

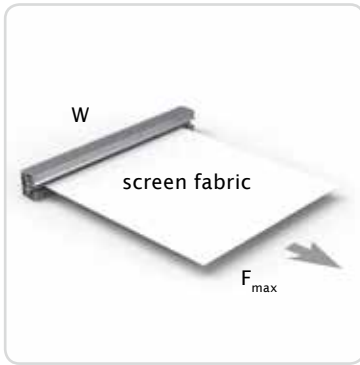

Test at tension

Allowed tension T_{max}

$$T_{max} = F_{max} / W = 13,5 \text{ (kg/cm)}$$

Conditions:

- Fixscreen® symmetrical zip principle
- Aluminium side channel 34 mm
- PVC side channel

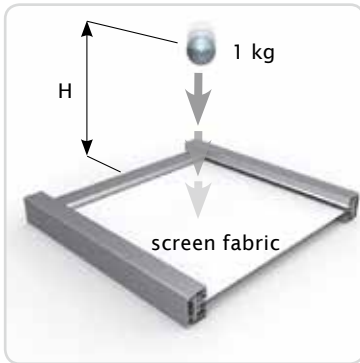

Collision test

Test: Ball (1 kg) dropped from different heights onto the screen

Result: Fabric tears apart before the zip-structure gets broken.

Fabric sample in test: Fibreglass Serge®

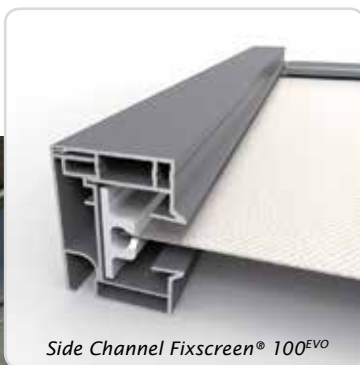

Side Channel Fixscreen® 100^{EVO}

Fabric selection

All recommended and commercially available fabrics for indoor and outdoor use.



Product specifications < Fixscreen®

Sections

Fixscreen® 85

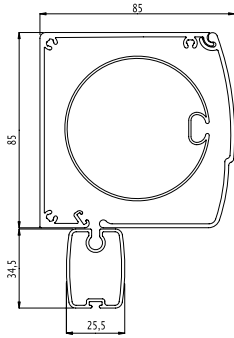

Side channel (S)

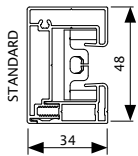

Coupling side channel (K)

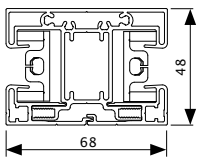

Fixscreen® 100^{EVO}

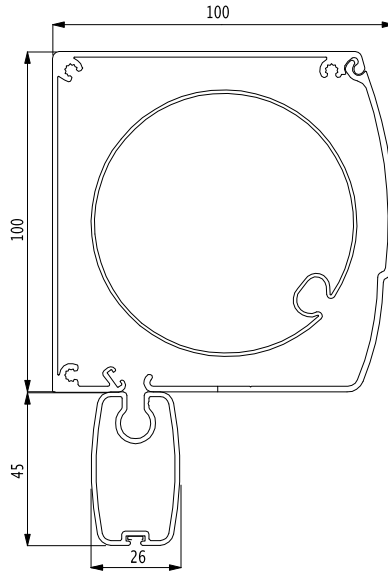

Side channels for Fixscreen® 100^{EVO} & 150^{EVO}

Open side channel (S)

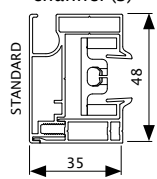

Closed side channel (G)

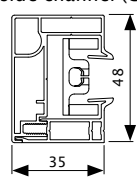

Coupling side channel (K)

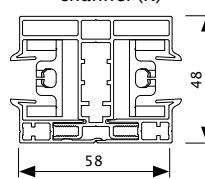

Fixscreen® 150^{EVO} / Fixscreen® 150^{EVO} F

Square design

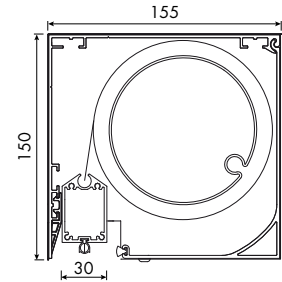

H ≤ 2700 mm

Softline design

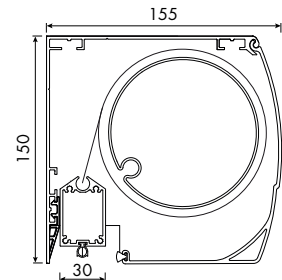

H ≤ 2700 mm

Technical features

	Fixscreen® 85	Fixscreen® 100 ^{EVO}	Fixscreen® 150 ^{EVO}	Fixscreen® 150 ^{EVO} F
GENERAL				
Material		EN AW-6063 T66		
Powder coating		60-80 micron		
Anodisation		20 micron		
DIMENSIONS (mm)				
Headbox (W x H)	85 x 85	100 x 100	155 x 150	155 x 150
Bottom bar (excl. light-block profile)	25,5 x 34,5	26 x 45	30 x 46	30 x 46
Side channels	34 x 48	35 x 48	35 x 48	35 x 48
Coupling side channel	68 x 48	58 x 48	58 x 48	38 x 48
Maximum	2500 x 1800	4000 x 2700 3000 x 3500	6000 x 3400 3200 x 6000	6000 x 2700 16,2 m ²
Max. 2-par t coupled (electrical only)	5000 x 1800	6000 x 2700	joinable	joinable
OPERATION				
Manual	Yes	Yes	No	No
Electrical	Yes	Yes	Yes	Yes
Connect&Go	No	Yes	Yes	Yes
INSTALLATION METHOD (see p. 13 and next)				
Installation method 1	Possible	Possible	Possible	Possible
Installation method 4	Possible	Possible	possible	Not possible
Installation method 5	Possible	Possible	Possible	Possible
Installation method 6	Possible	Possible	Possible	n.a.
Installation method 7	Not possible	Possible	possible	Not possible

Subject to technical changes.



Fixscreen® 100EVO

The screen headbox

The box is constructed of extruded aluminium profiles.

The ends have side consoles that support the roll-up mechanism and are equipped with pins to slide the box onto the side channels.

The box is closed by means of a rounded front profile that hinges into the box and can be disassembled.

Box material:

Aluminium extrusion profile, alloy EN AW-6063 T66

Surface treatment: Anodised, 20 micron

Powder coating in RAL colours, 60-80 micron

Side console material:

Fixscreen® 85:

ASA

Available in 4 standard colours:

white, grey, cream & black

Fixscreen® 100^{EVO} & 150^{EVO} (F): Aluminium

Powder coating in RAL colours, 60-80 micron



Fixscreen® 100EVO

Fabric roll

The fabric roller barrel with groove is made of steel and has a unique sunken fabric groove to limit the impression of the fabric loop. That will strongly reduce the horizontal line formation in the fabric.

The endpieces of the fabric roller barrel are conical to compensate for the thicker ends of the zip when it is rolled up: patented technology!

Material: Steel

The bottom bar

The bottom bar, made of extruded aluminium, is solid and is made heavier with a round bar of galvanised steel. That is covered by PE foam to prevent contact between the aluminium and steel.

For a perfect connection with the sill, the bottom bar has a plastic darkening strip.

Material: Aluminium extrusion profile, alloy EN AW-6063 T66

Surface treatment: Anodised, 20 micron

Powder coating in RAL colours, 60-80 micron



Fixscreen® 100EVO

The side channel

The side channel and the coupling side channel are made of extruded aluminium.

The side channel is in two parts; the coupling side channel comes in three parts.

For Fixscreen® 150^{EVO}, the side channel comes in three parts (IM7).

They are both pre-drilled for easy assembly. No screws are visible at the front.

The internal guide is made of HPVC with neoprene buffer zones that are 60 mm long to compensate for wind gusts. The zip is slid into this internal plastic guide

and the fabric is held fast.

Sufficient tolerance has been provided between the fabric, the aluminium side channel and the internal guide to guarantee smooth use.

The side channels of the Fixscreen® 100^{EVO} and the Fixscreen® 150^{EVO} have an extra channel to conceal the cable!

Material of the exterior side channel:

Aluminium extrusion profile, alloy EN AW-6063 T66

Surface treatment: Anodised, 20 micron

Powder coating in RAL colours, 60-80 micron



Fixscreen® 100EVO

Product specifications < Fixscreen® Mono AK

Sections

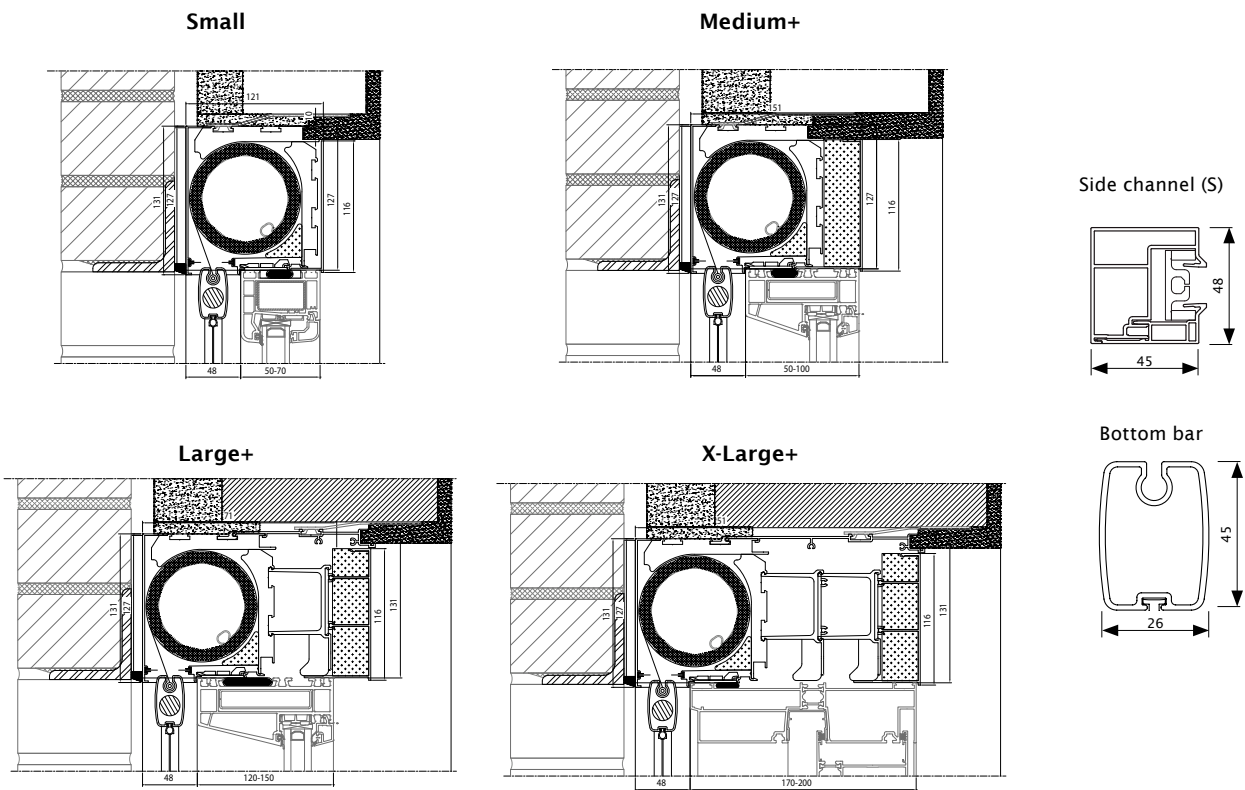

Technical Features

	Small	Medium+	Large+	X-Large+
Suitable for frame thickness (mm)	50-70	71-100	101-150	151-200
Box (W x H) (mm)	121 x 127	151 x 131	201 x 131	251 x 131
Max. dimensions (W x H) (mm)	4000 x 2700 or 3000 x 3500			
Control	Motor	Motor	Motor	Motor
Possibility to couple	No	No	No	No
Extra acoustic / thermal material	No	Yes	Yes	Yes
U_{is} value (W/(m ² .K))*	1,6	1,4	1,4	1,4
Sound reduction $D_{n,e,w}(C;C_{tr})$ (dB) (screen rolled up)	47 (0;-2)	50 (-1;-2)	50 (-1;-2) **	50 (-1;-2) **

* According to EN 10077-2 when U_{is} = coefficient of thermal transmission

** To be tested officially





Fixscreen® Mono AK

Screen headbox

The box is made of multi-chamber PVC profiles. This multi-chamber system guarantees excellent thermal & acoustic insulation.

The PVC box is finished using 2 extruded aluminium profiles available in the same colours as the joinery. The sides of the box are fitted with aluminium end covers, which support the roller mechanism and are fitted with pins to slide the box onto the side channels. The rear Alu profile is removable and the rear PVC profile hinges in the box can be disassembled.

Box material: PVC composite extrusion profile

Side console material: ASA
Available in 2 standard colours: cream, black

Material finishing profile: Aluminium extrusion profile, alloy EN AW-6063 T66
Surface treatment: Anodised, 20 micron
Powder coating in RAL colours, 60-80 micron



Fixscreen® Mono AK

Fabric roll

The fabric roller with groove is made of steel and has a unique sunken fabric groove to limit the impression of the fabric loop. That will strongly reduce the horizontal line formation in the fabric.

The endpieces of the fabric roller barrel are conical to compensate for the thicker ends of the zip when it is rolled up: patented technology!

Material: steel

The bottom bar

The bottom bar, made of extruded aluminium, is solid and is made heavier with a round bar of galvanized steel. That is covered by PE foam to prevent contact between the aluminium and steel.

For a perfect connection with the sill, the bottom bar has a plastic darkening strip.

Material: Aluminium extrusion profile, alloy EN AW-6063 T66
Surface treatment: Anodised, 20 micron
Powder coating in RAL colours, 60-80 micron



Fixscreen® Mono AK

The side channel

The side channels are made of extruded aluminium. The external side channel consists of 2 parts. They are screwed directly on the frame. The screws are not visible from the front.

The internal channel is made of HPVC and is fitted with neoprene buffer zones (60mm long) to compensate for wind gusts. The zip, which is welded to the fabric, slides onto those HPVC side channels and the fabric is 'held fast' in that way. When installed correctly, there is sufficient clearance between the screen and the aluminium side channels and the HPVC side guides to ensure smooth operation.

Material external side channel:

Aluminium extrusion profile, alloy EN AW-6063 T66
Surface treatment: Anodised, 20 micron
Powder coating in RAL colours, 60-80 micron

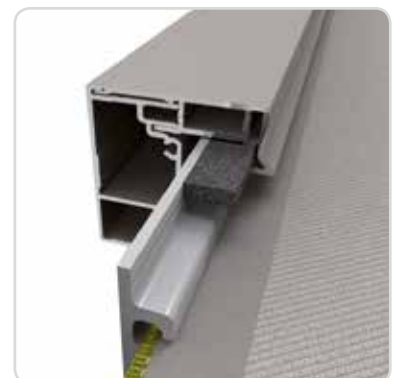

Fixscreen® Mono AK



When the Fixscreen® was developed, user friendliness and easy installation were made priorities. The box is self-supporting and is installed on the side channels.

There are 4 installation methods:

→ towards disassembly fabric roller barrel with fabric and motor.

Installation method 1

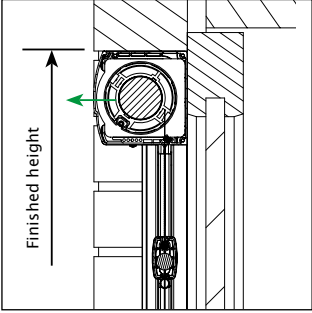

Surface-mounted, outside, in front of the window

Installation method 4
Interior to be finished by a carpenter

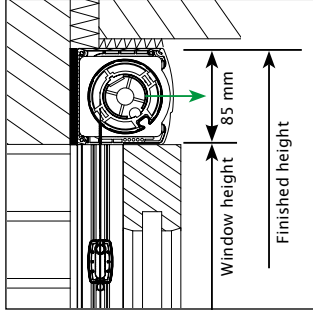

Hidden installation, reversed box, on top of the window with box, without front cover

Installation method 5
Interior to be finished by a carpenter

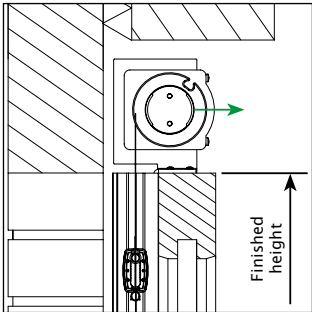

Hidden installation, with brackets, without box

Installation method 6

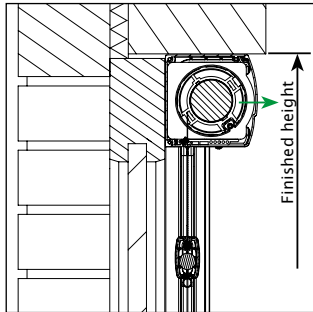

Surface-mounted, inside, in front of the window

Standard side channel (S)

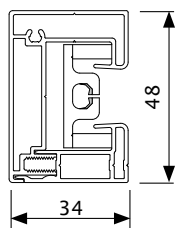

Coupling side channel (K)

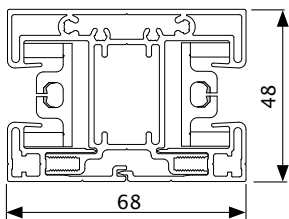

Side channels

		S	K
FIXSCREEN® 85	IM1	STANDARD	x
	IM4	STANDARD	x
	IM5	STANDARD	x
	IM6	STANDARD	x

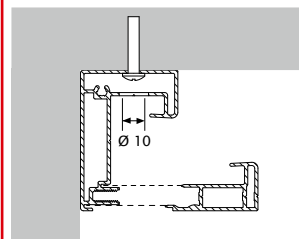

Rear mounting of the side channel Fixscreen® 85

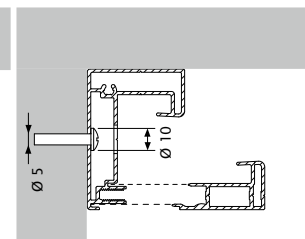

Side mounting of the side channel Fixscreen® 85

Installation < Fixscreen® 100^{EVO}

There are 5 installation methods possibilities:

→ towards disassembly fabric roller barrel with fabric and motor.

Installation method 1

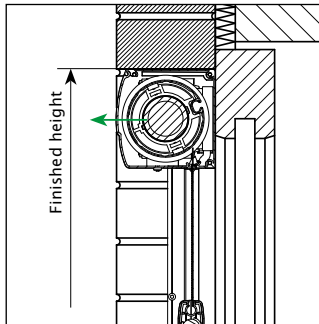

Surface-mounted, outside, in front of the window

Installation method 4

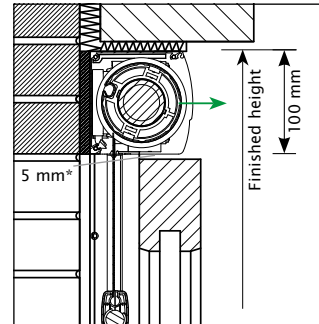

Hidden installation, reversed box, on top of the window with box, **without front cover**
* 5 mm extra between window height and bottom of Fixscreen® box

Installation method 5

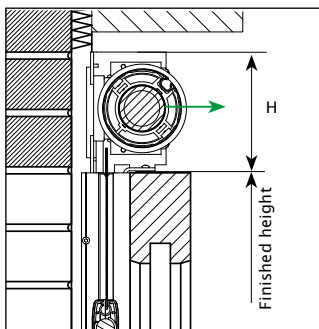

Hidden installation, with brackets, without box

Installation method 6

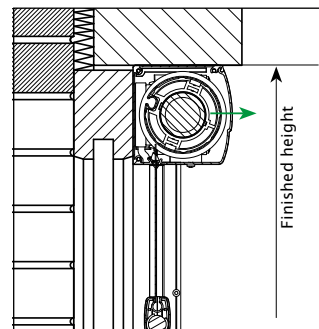

Surface-mounted, inside, in front of the window

Installation method 7 NEW

fabric roller & motor can always be removed from the outside, downwards

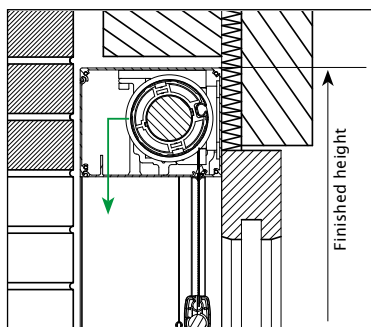

Hidden installation, in front/above the window

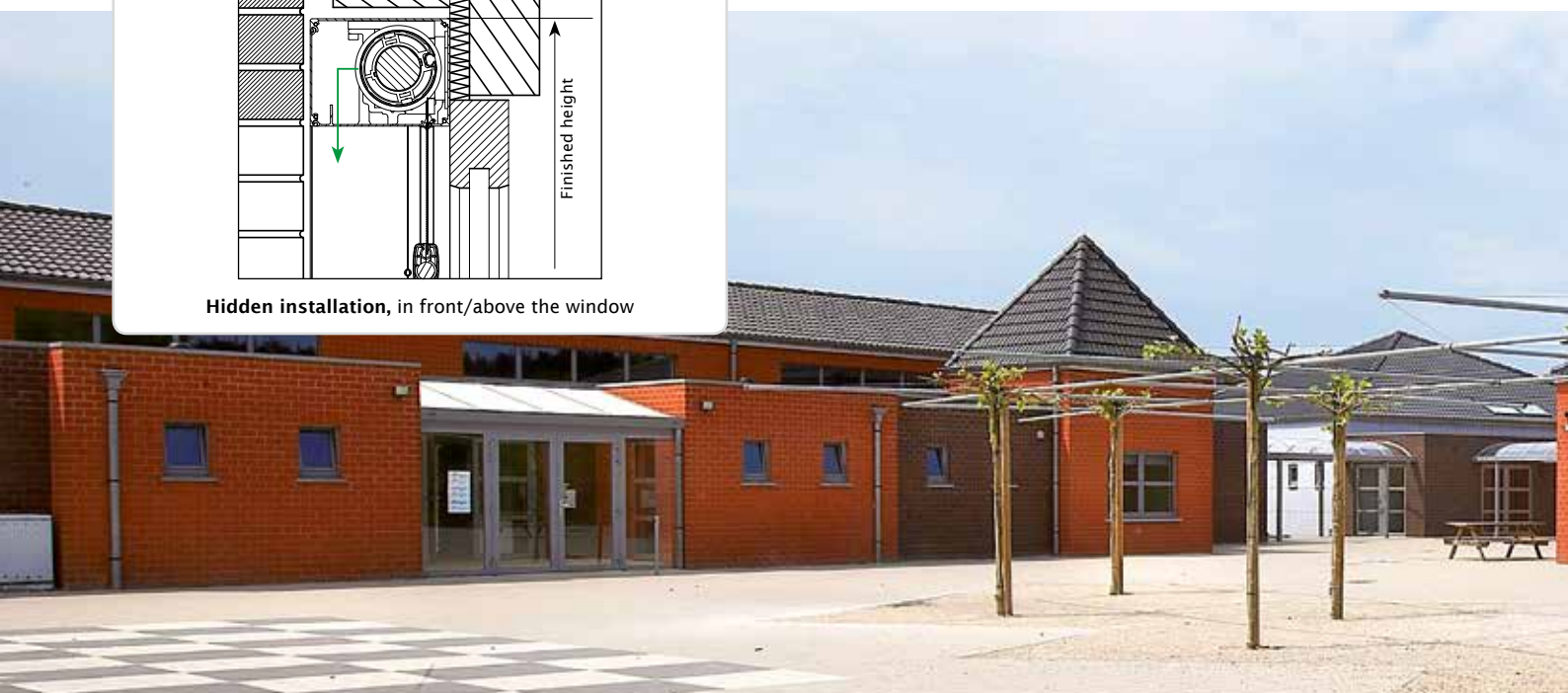

Side channels

		S	G	K	D
FIXSCREEN® 100 ^{EVO}	IM1	STANDARD	x	x	
	IM4	STANDARD	x	x	
	IM5	STANDARD	x	x	
	IM6	STANDARD	x	x	
	IM7	x*	x*	x	STANDARD

* To be able to disassemble the fabric roller barrel from beneath in case of IM7, the client must foresee something underneath the headbox that can be dismantled when choosing the narrow side channels S x G. The dimensions of this dismantlable part are determined as follows: the minimum depth equals the depth of the box less the depth of the narrow side channel and with a minimal height of 680 mm

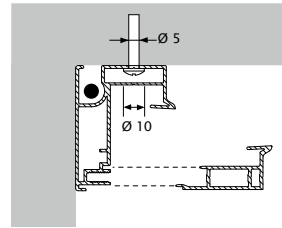

Rear mounting of the side channel Fixscreen® 100^{EVO}

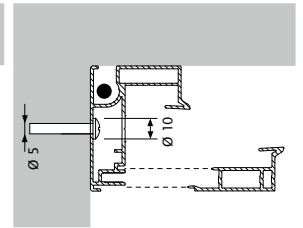

Side mounting of the side channel Fixscreen® 100^{EVO}

open side channel (S)

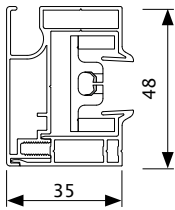

closed side channel (G)

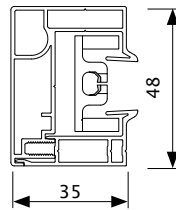

Coupling side channel (K)

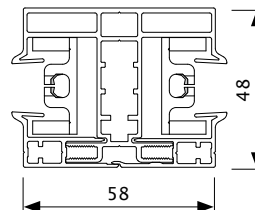

deep side channel (D)

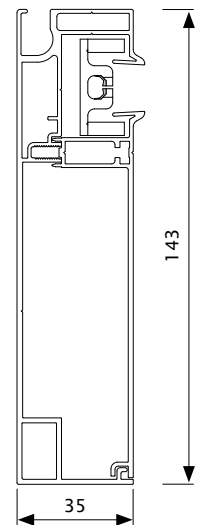

Box extension

Is possible in installation methods 1 & 6 (Fixscreen®100^{EVO}). The box profiles extend all the way to the consoles. This extension can be made to the left and/or to the right with 500 mm.



Several methods of extension are then made possible. 2 box extensions can be positioned next to another, making an angle.



Installation < Fixscreen® 150^{EVO} (F)

There are 5 installation methods possibilities:

→ towards disassembly fabric roller barrel with fabric and motor

Installation method 1

Square design

Softline design

surface-mounted, outside, in front of window

Installation method 4

Square design

Hidden installation, reversed box, on top of the window with box, without front cover

Installation method 5

Hidden installation, with brackets, without box

Installation method 6

Square design

Softline design

Surface-mounted, inside, in front of window

Installation method 7

Square design

Surface-mounted, front / on top of the window with box

Side channels

	S	G	K	D
Fixscreen®	IM1 standard	x	x	-
150 ^{EVO} (F)	IM4 -	standard	x	-
	IM5 standard	x	x	-
	IM6 standard	x	x	-
	IM7 -	x	x	standard

Rear mounting of the side channel Fixscreen® 150^{EVO} (F)

Side mounting of the side channel Fixscreen® 150^{EVO} (F)

IM7: deep side channel (D)

IM1 / IM4 / IM5 / IM6 / IM7:

Open side channel (S)

Closed side channel (G)

Closed side channel (G) IM7

Coupling side channel (K)

When installing the Fixscreen® Mono AK, it is mounted on the window profiles as a monobloc.

There are 4 versions depending on the frame thicknesses:

→ towards disassembly fabric roller barrel with fabric and motor

Installation method 4: Fixscreen® Mono AK Small

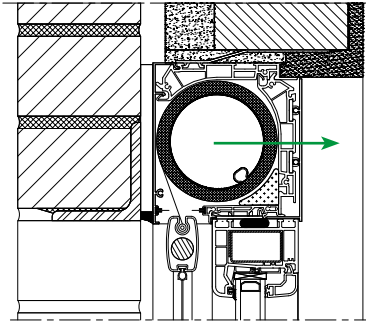

Hidden installation, on top of the window

Installation method 4: Fixscreen® Mono AK Medium+

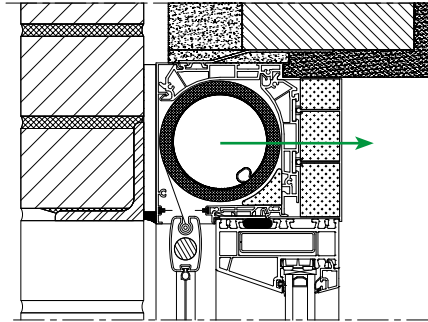

Hidden installation, on top of the window

Installation method 4: Fixscreen® Mono AK Large+

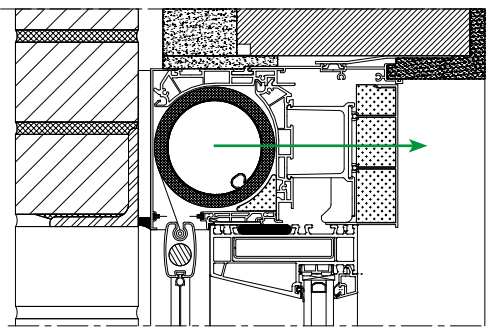

Hidden installation, on top of the window

Installation method 4: Fixscreen® Mono AK X-Large+

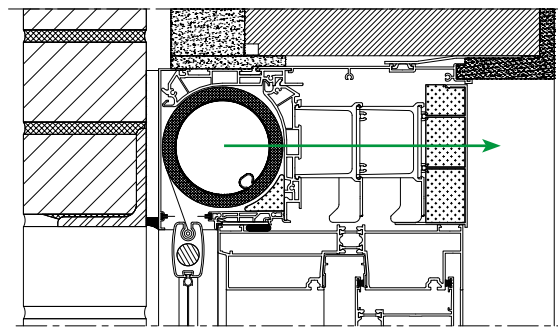

Hidden installation, on top of the window

Installation method 4: Fixscreen® Mono AK - finished by carpenter

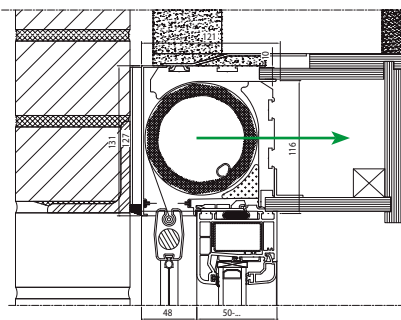

Hidden installation, on top of the window

Standard side channel (S)

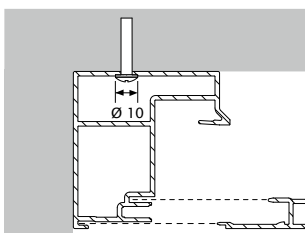
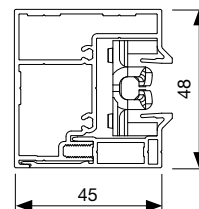

Rear mounting of the side channel Fixscreen® Mono AK

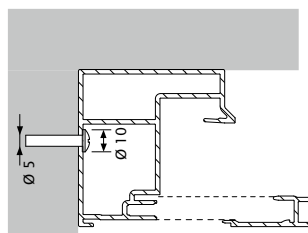

Side mounting of the side channel Fixscreen® Mono AK

Methods of operation

For manual operation, you have a choice of:

- A fixed crank
- A removable crank

For electrical operation, you have a choice of:

- Somfy, mechanical motor
- Somfy, electronic WT motor:
 - Fixscreen® 100^{EVO} and Fixscreen® Mono Ak up to a maximum finished height of 2700 mm
- Somfy, radio-controlled motor
- Somfy, IO - Homecontrol powered motor:
 - only for Fixscreen® 100^{EVO} up to a maximum finished height of 2700 mm



Fixed crank



Removable crank (Tulipe)



Somfy motor: radio controlled



Connect&Go technology



The Fixscreen® 100^{EVO} and the Fixscreen® 150^{EVO} has the new and revolutionary Connect&Go technology! This technology simplifies

- installing and removing of the fabric roller barrel
- replacing the fabric
- replacing the motor
- securing the headbox

This patented Connect&Go technology is a water tight, electrical connection with CE certification:

EC declaration of conformity

NV RENSON® Sunprotection-Screens SA
Kalkhoevestraat 45
8790 Waregem • Belgium

EC DECLARATION OF COMPLIANCE

RE: FIXSCREEN® 100^{EVO}

Brand: RENSON® Sunprotection-Screens NV/SA
Type: MS1 - MS4 - MS5 - MS6 - MS7

The undersigned, Mr Paul Renson, authorised by RENSON® Sunprotection-Screens NV/SA hereby declares that the aforementioned machine, if installed, maintained and use in accordance with the enclosed instructions and the rules of good practice, is in compliance with the following EEC directives:

- the machines directive 2006/42/EC
- the low-tension directive 2006/95/EC
- he EMC directive 2004/108/EC

Date: 21/03/2011

Name: Paul Renson

Signature: 

Reference:
RAP VV/GDB-20100927-1 certificate,
RAP DO/GDB-20110318-1 certificate
RAP DO/GDB-20110321-1 certificate
issued by J. VAN HEMELLEN, Kortrijk, Belgium

Extra

The electrical contract work includes the necessary power connections up to the relay boxes using a wiring lay-out specified by the supplier. Wires will run between the relays and each motor, the control switches and equipment as well as the measuring instruments. The electrician will also install a distribution box in which the manufacturer of the sun protecting screen can also directly connect the motor cable later. The motor cable can be connected directly without a distribution box if the motor cable is long enough.





Throughput & position

The location of the throughput depends on the choice of method of operation. The operating mechanism can be positioned on the left or right, at the installer's discretion.

- R & L: Position right or left
- A & B: Throughput crank and motor cable
- D: Throughput crank
- F, G, H, I, J & T: Throughput motor cable
- K: Throughput motor cable in side channel

Fixscreen® 85

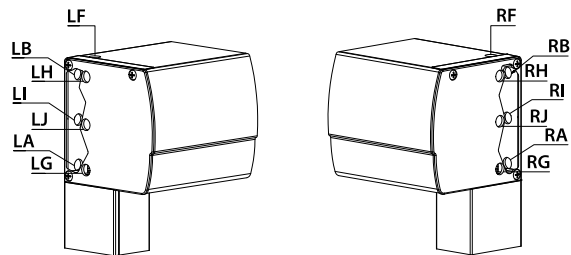

Fixscreen® 100^{EVO}

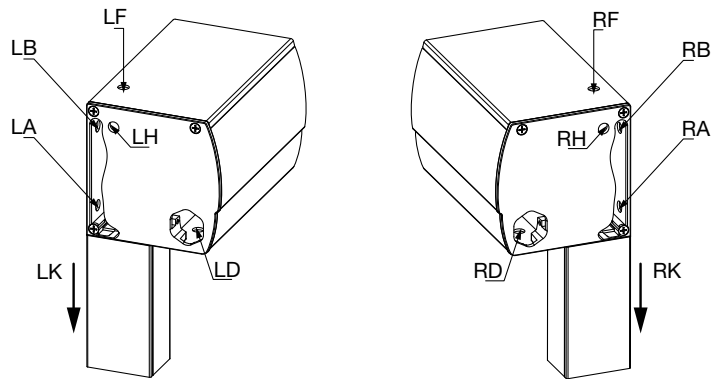

Fixscreen® 150^{EVO} (F)

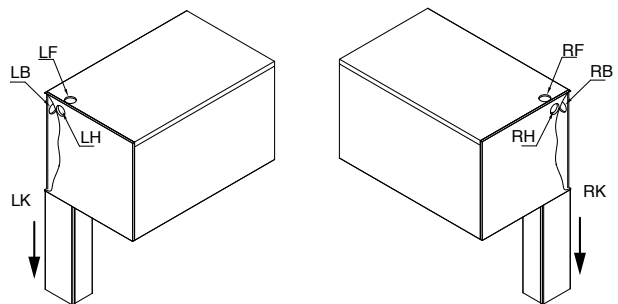

Fixscreen® Mono AK

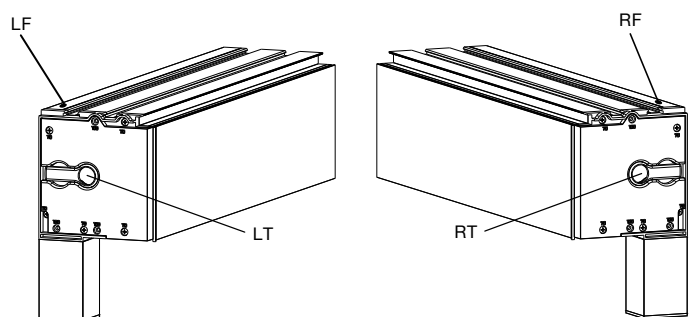

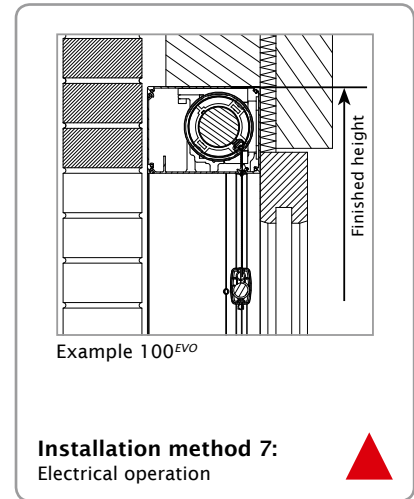
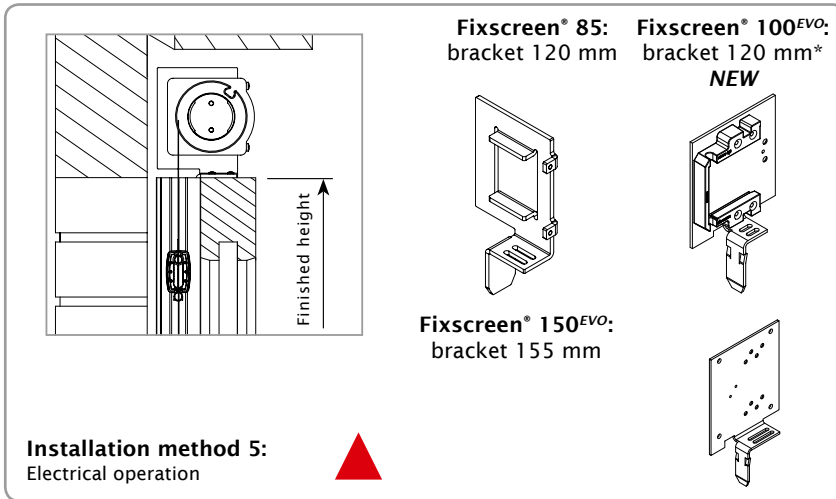

* Available from September 2013

Fixscreen® 150^{EVO} (F)

- ▲ Fixscreen® 150^{EVO}: installation method 1, 4, 5, 6 & 7; electrical operation: minimum width 840 mm; joinable (7000 mm)
- Fixscreen® 150^{EVO} F: installation method 1 & 5; electrical operation: minimum width 1000 mm, maximum width 6000 mm, maximum Height 2700 mm; joinable (7000 mm)

Fixscreen® 150^{EVO} (F):

- Bottomrail disappears into the box:
- Completely up to max. height of 2700 mm
- Partially up to max. height 6000 mm

		Width																										
m x m		1,00	1,20	1,40	1,60	1,80	2,00	2,20	2,40	2,60	2,80	3,00	3,20	3,40	3,60	3,80	4,00	4,20	4,40	4,60	4,80	5,00	5,20	5,40	5,60	5,80	6,00	
Height	1,00	▲	▲	▲	▲	▲	▲	▲	▲	▲	▲	▲	▲	▲	▲	▲	▲	▲	▲	▲	▲	▲	▲	▲	▲	▲	▲	
	1,20	▲	▲	▲	▲	▲	▲	▲	▲	▲	▲	▲	▲	▲	▲	▲	▲	▲	▲	▲	▲	▲	▲	▲	▲	▲	▲	▲
	1,40	▲	▲	▲	▲	▲	▲	▲	▲	▲	▲	▲	▲	▲	▲	▲	▲	▲	▲	▲	▲	▲	▲	▲	▲	▲	▲	▲
	1,60	▲	▲	▲	▲	▲	▲	▲	▲	▲	▲	▲	▲	▲	▲	▲	▲	▲	▲	▲	▲	▲	▲	▲	▲	▲	▲	▲
	1,80	▲	▲	▲	▲	▲	▲	▲	▲	▲	▲	▲	▲	▲	▲	▲	▲	▲	▲	▲	▲	▲	▲	▲	▲	▲	▲	▲
	2,00	▲	▲	▲	▲	▲	▲	▲	▲	▲	▲	▲	▲	▲	▲	▲	▲	▲	▲	▲	▲	▲	▲	▲	▲	▲	▲	▲
	2,20	▲	▲	▲	▲	▲	▲	▲	▲	▲	▲	▲	▲	▲	▲	▲	▲	▲	▲	▲	▲	▲	▲	▲	▲	▲	▲	▲
	2,40	▲	▲	▲	▲	▲	▲	▲	▲	▲	▲	▲	▲	▲	▲	▲	▲	▲	▲	▲	▲	▲	▲	▲	▲	▲	▲	▲
	2,60	▲	▲	▲	▲	▲	▲	▲	▲	▲	▲	▲	▲	▲	▲	▲	▲	▲	▲	▲	▲	▲	▲	▲	▲	▲	▲	▲
	2,80	▲	▲	▲	▲	▲	▲	▲	▲	▲	▲	▲	▲	▲	▲	▲	▲	▲	▲	▲	▲	▲	▲	▲	▲	▲	▲	▲
	3,00	▲	▲	▲	▲	▲	▲	▲	▲	▲	▲	▲	▲	▲	▲	▲	▲	▲	▲	▲	▲	▲	▲	▲	▲	▲	▲	▲
	3,20	▲	▲	▲	▲	▲	▲	▲	▲	▲	▲	▲	▲	▲	▲	▲	▲	▲	▲	▲	▲	▲	▲	▲	▲	▲	▲	▲
	3,40	▲	▲	▲	▲	▲	▲	▲	▲	▲	▲	▲	▲	▲	▲	▲	▲	▲	▲	▲	▲	▲	▲	▲	▲	▲	▲	▲
	3,60	▲	▲	▲	▲	▲	▲	▲	▲	▲	▲	▲	▲	▲	▲	▲	▲	▲	▲	▲	▲	▲	▲	▲	▲	▲	▲	▲
	3,80	▲	▲	▲	▲	▲	▲	▲	▲	▲	▲	▲	▲	▲	▲	▲	▲	▲	▲	▲	▲	▲	▲	▲	▲	▲	▲	▲
	4,00	▲	▲	▲	▲	▲	▲	▲	▲	▲	▲	▲	▲	▲	▲	▲	▲	▲	▲	▲	▲	▲	▲	▲	▲	▲	▲	▲
	4,20	▲	▲	▲	▲	▲	▲	▲	▲	▲	▲	▲	▲	▲	▲	▲	▲	▲	▲	▲	▲	▲	▲	▲	▲	▲	▲	▲
	4,40	▲	▲	▲	▲	▲	▲	▲	▲	▲	▲	▲	▲	▲	▲	▲	▲	▲	▲	▲	▲	▲	▲	▲	▲	▲	▲	▲
4,60	▲	▲	▲	▲	▲	▲	▲	▲	▲	▲	▲	▲	▲	▲	▲	▲	▲	▲	▲	▲	▲	▲	▲	▲	▲	▲	▲	
4,80	▲	▲	▲	▲	▲	▲	▲	▲	▲	▲	▲	▲	▲	▲	▲	▲	▲	▲	▲	▲	▲	▲	▲	▲	▲	▲	▲	
5,00	▲	▲	▲	▲	▲	▲	▲	▲	▲	▲	▲	▲	▲	▲	▲	▲	▲	▲	▲	▲	▲	▲	▲	▲	▲	▲	▲	
5,20	▲	▲	▲	▲	▲	▲	▲	▲	▲	▲	▲	▲	▲	▲	▲	▲	▲	▲	▲	▲	▲	▲	▲	▲	▲	▲	▲	
5,40	▲	▲	▲	▲	▲	▲	▲	▲	▲	▲	▲	▲	▲	▲	▲	▲	▲	▲	▲	▲	▲	▲	▲	▲	▲	▲	▲	
5,60	▲	▲	▲	▲	▲	▲	▲	▲	▲	▲	▲	▲	▲	▲	▲	▲	▲	▲	▲	▲	▲	▲	▲	▲	▲	▲	▲	
5,80	▲	▲	▲	▲	▲	▲	▲	▲	▲	▲	▲	▲	▲	▲	▲	▲	▲	▲	▲	▲	▲	▲	▲	▲	▲	▲	▲	
6,00	▲	▲	▲	▲	▲	▲	▲	▲	▲	▲	▲	▲	▲	▲	▲	▲	▲	▲	▲	▲	▲	▲	▲	▲	▲	▲	▲	

Tables subject to technical changes.



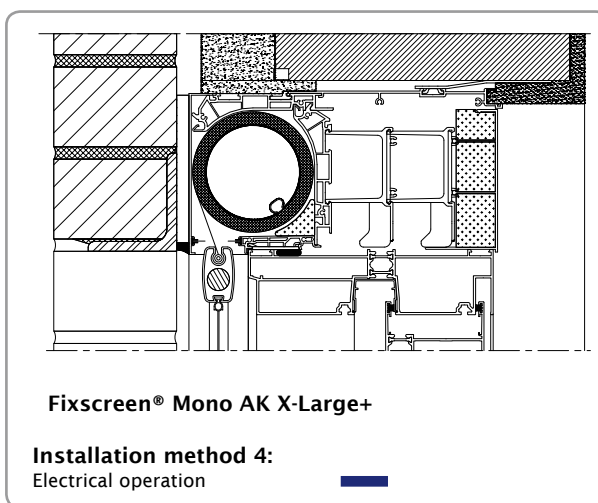
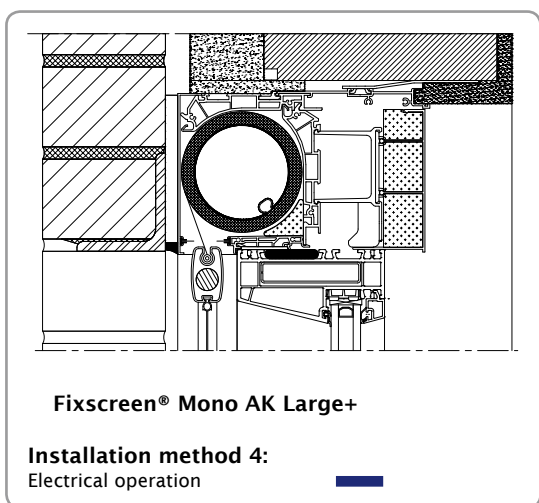
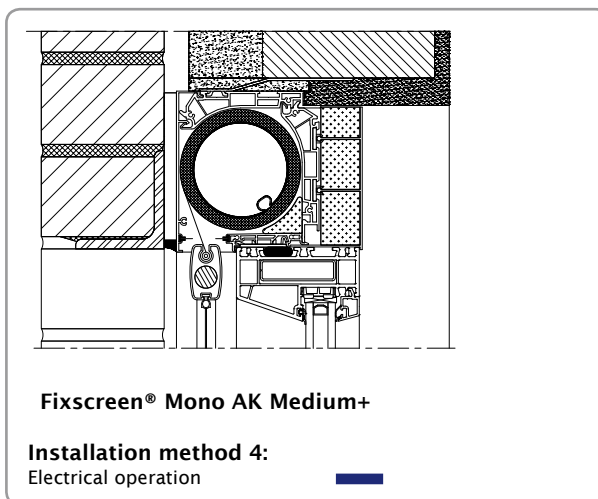
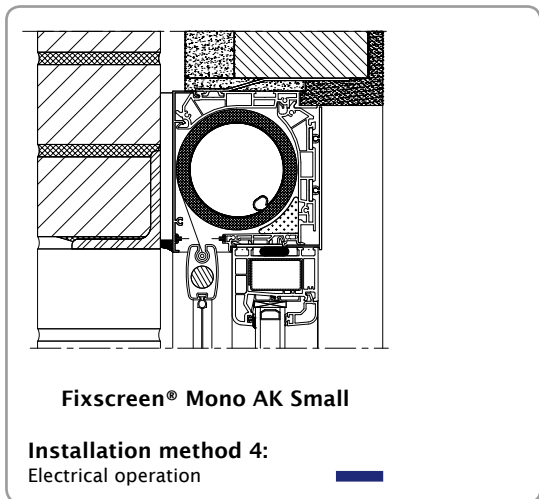

Fixscreen® Mono AK

- Installation method 4, electrical operation: minimum width of 820 mm, not joinable

m x m	Width															
	1,00	1,20	1,40	1,60	1,80	2,00	2,20	2,40	2,60	2,80	3,00	3,20	3,40	3,60	3,80	4,00
1,00	-	-	-	-	-	-	-	-	-	-	-	-	-	-	-	-
1,20	-	-	-	-	-	-	-	-	-	-	-	-	-	-	-	-
1,40	-	-	-	-	-	-	-	-	-	-	-	-	-	-	-	-
1,60	-	-	-	-	-	-	-	-	-	-	-	-	-	-	-	-
1,80	-	-	-	-	-	-	-	-	-	-	-	-	-	-	-	-
2,00	-	-	-	-	-	-	-	-	-	-	-	-	-	-	-	-
2,20	-	-	-	-	-	-	-	-	-	-	-	-	-	-	-	-
2,40	-	-	-	-	-	-	-	-	-	-	-	-	-	-	-	-
2,60	-	-	-	-	-	-	-	-	-	-	-	-	-	-	-	-
2,70	-	-	-	-	-	-	-	-	-	-	-	-	-	-	-	-
2,80	-	-	-	-	-	-	-	-	-	-	-	-	-	-	-	-
3,00	-	-	-	-	-	-	-	-	-	-	-	-	-	-	-	-
3,20	-	-	-	-	-	-	-	-	-	-	-	-	-	-	-	-
3,40	-	-	-	-	-	-	-	-	-	-	-	-	-	-	-	-
3,50	-	-	-	-	-	-	-	-	-	-	-	-	-	-	-	-

Tables subject to technical changes.

Types of fabric

Fibreglass fabric

This screen fabric is woven from fibreglass threads with a PVC coating. Fabric made of fibreglass retains its shape, does not suffer from moisture or heat, will not rot and is colour fast. The sides of the finished fabric are reinforced with a transparent band that is 13 mm wide and 0.6 mm thick (included fabric). The upper and lower side have a welded seam through which a screen cord has been threaded. For a selection of 7 colours : horizontale weld if height > 3200 mm. At heights greater than 2700 mm, the fabric also has a horizontal welding seam.



Fibreglass fabric sampler

Soltis® polyester fabric

This type of fabric is made of finely meshed tissue with a fire-retardant PVC coating (fire classification IM1/IM2, depending on the colour) using the précontraint method. That means that the warp and weft of the polyester tissue is pre-stretched before and during the coating process. That creates an extremely stable and firm fabric, resulting in a long lifespan. At heights greater than 1770 mm, the Soltis® 86 & 92 fabrics also have a horizontal welding seam. For a selection of 10 colours for Soltis® 86 & 92 : horizontale weld if height > 2670 mm. At heights greater than 2670 mm, the Soltis® 93 fabric also has a horizontal welding seam.



Soltis® fabric sampler

Light-block fibreglass fabric

Technical fabric of fibreglass threads (42%) with a blackout PVC coating (58%).
Caution! Only for use on the interior of the building, exceptional for Miniscreen®.
At heights greater than 1400 mm or 2100 mm, the fabric also has a horizontal welding seam.

Light-block Soltis® B92 polyester fabric

Fine polyester mesh fabric with a fire-retardant PVC coating using the précontraint method. The back side also has a blackout PVC coating. Soltis® B92 is 100% recyclable. The blackout polyester fabric can be used inside and outside the building.

In case of application outside, there is a restriction that it is only applicable with:

- Fixscreen® 100^{EVO} / Fixscreen® Mono AK:
 - Minimal width: 1000 mm
 - Maximal width: 2000 mm
 - Maximal height: 2700 mm
- Fixscreen® 150^{EVO}:
 - Minimal width: 1000 mm
 - Maximal height: 4000 mm
 - Maximal surface: 16 m²



Light-block fabric sampler

At heights greater than 1700 mm, the Soltis® B92 fabric has a horizontal welding seam.

Insectscreen

Fixscreen® 85, 100^{EVO} & Mono AK can also have mosquito netting in the following colours:



ISR Grey



ISR Charcoal



ISR Zebra

At heights greater than 2400 mm, the mosquito netting has a horizontal welding seam.

For more information: see our "Screen fabric types" technology brochure.

Overview

	Fibreglass fabric	Soltis® 86	Soltis® 92	Soltis® 93	Soltis® B92	Insect screen
Fixscreen® 85	✓	✓	✓	✓	✓*	✓
Fixscreen® 100 ^{EVO}	✓	✓	✓	✓	✓	✓
Fixscreen® 150 ^{EVO}	✓	✓	✓	✓	✓	-
Fixscreen® 150 ^{EVO} F	✓	-	-	-	-	-
Fixscreen® Mono AK	✓	✓	✓	✓	✓	✓

Remarks: Applicable screens, see price list
*Exclusively for interior use

Crystal fabric (Fixscreen® 150^{EVO} F)

In order to have optimal contact with the exterior, transparent Crystal fabric can be fitted in the Fixscreen® 150^{EVO} F.

There exist various possibilities of positioning the crystal fabric, in which can be chosen between three types of windows:

- a window of 1200mm by 1200mm
- a window across the width of the screen and 1200mm high
- a window in the height of the screen and 1200mm wide

For each screen, maximum 2 crystal windows can be integrated.

Horizontally, the distance to the edge of the fabric or between two windows must be at least 200mm. Vertically, the distance to the edge of the fabric or between two windows must be at least 400mm.

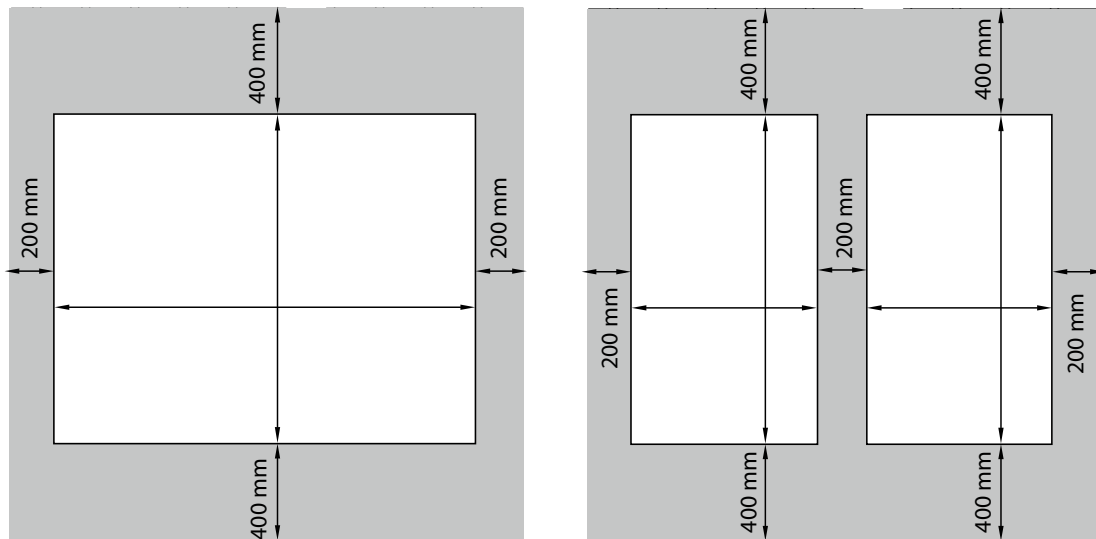

Fabrics in Renson® sun protection & terrace coverings

Type of fabric	Acryl fabric		Glass fibre	Polyester fabric			Blackout fabric			Renson® Exclusive			Insect fabric
	Dickson®	Dickson® Orchestra Max		Sergé®	Soltis® 86	Soltis® 92	Soltis® 93	Dual 13137	Satiné 21154	Soltis® B92	Rensonscreen®	Rensonscreen® Waterproof	
Vertical sunscreens													
Fixscreen® 85	-	-	✓	✓	✓	✓	✓*	✓*	✓*	✓	-	-	✓
Fixscreen® 100 ^{EVO}	-	-	✓	✓	✓	✓	✓*	✓*	✓	✓**	-	-	✓
Fixscreen® 150 ^{EVO}	-	-	✓	✓	✓	✓	✓*	✓*	✓	-	-	-	-
Fixscreen® 150 ^{EVO} F (free)	-	-	✓	-	-	-	-	-	-	-	-	-	-
Fixscreen® Mono AK ^{EVO}	-	-	✓	✓	✓	✓	-	-	✓	✓**	-	-	✓
Miniscreen® 63	-	-	✓	✓	✓	✓	✓	✓	✓	✓	-	-	-
Miniscreen® 83/100	-	-	✓	✓	✓	✓	✓	✓	✓	✓**	-	-	-
Screenvent®	-	-	✓	✓	✓	✓	✓	✓	✓	✓**	-	-	-
Screenvent® Mistral AK/UT (Fixvent® Mono AK ^{EVO})	-	-	✓	✓	✓	✓	-	-	✓	✓**	-	-	✓
Horizontal sunscreens													
Topfix®	-	-	-	✓	✓	✓	-	-	✓	✓**	-	-	-
Topfix® Max	-	-	-	✓	✓	✓	-	-	✓	✓	-	✓	-
Topfix® Max F (free)	-	-	-	✓	✓	✓	-	-	-	✓	✓	-	-
Vegascreen®	✓	✓	-	✓	✓	✓	-	-	✓	✓	-	✓	-
Verandascreen®	✓	✓	-	✓	✓	✓	-	-	✓	✓	-	✓	-
Prestige®	✓	✓	-	-	-	-	-	-	-	-	-	-	-
Skyline®	✓	✓	-	-	-	-	-	-	-	-	-	-	-
Swingline®	✓	✓	-	-	-	-	-	-	-	-	-	-	-
Terrace coverings													
Lagune® Rooffix	-	-	-	-	-	-	-	-	-	-	✓	-	-
Lagune® Triangle	-	-	✓	-	-	-	-	-	-	✓	-	-	-
Lagune® with integrated Fixscreen®	-	-	✓	-	-	-	-	-	-	✓**	-	-	-
Camargue® with integrated Fixscreen®	-	-	✓	-	-	-	-	-	-	-	-	-	-
Loggiascreen®	-	-	✓	✓	✓	✓	-	-	-	✓	-	-	-
Loggiascreen® 4FIX	-	-	-	✓	✓	✓	-	-	-	✓	-	-	-
Remarks: Applicable screens, see price list.													
(*) Exclusively for interior use.													
(**) Max width 2500 mm & max surface 7m ²													

Overview top 20 RAL

All our fixscreens are manufactured from anodised aluminium profiles or in all standard RAL colours available

RAL 1013



RAL 1015



RAL 7016



RAL 7021



RAL 7030



RAL 7039



RAL 8019



RAL 9001

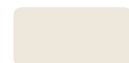

RAL 9007



RAL 9010



RAL 9016



MAT 7016



MAT 7021



MAT 7030



MAT 7039



MAT 9001

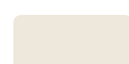

MAT 9006



MAT 9007



RYD 7M16



RYD 7M21



* Printed colours may deviate slightly, from real RAL colours. Use this scheme only as a reference.



Maintenance

The system requires little maintenance, but we do advise the following to ensure years of sun-protection enjoyment.

- If the fabric gets wet in an unexpected shower, you can roll it up without problems and then roll it out later to allow it to dry. Do not allow the fabric to stay rolled up wet for longer than three days; that will help prevent mould and stains.
- Before cleaning, remove loose dirt with a brush or vacuum cleaner. You can then remove the remaining dirt with a cleaning product and warm water (special cleaning products are available from the installer). Always rinse the fabric after cleaning. Avoid cleaning in full sunlight: if the soapy water dries quickly, it can leave stains on the fabric. Do not use abrasive products to clean.
- The hinges and moving parts should be lubricated at least annually. A dry lubricant (Teflon) should be used to do so.
- As the manufacturer, we recommend having a technical inspection of your installation carried out regularly by the installer.
 - Annually for utilities buildings.
 - Every 4 years for residential sun protection.
- Always use original parts for maintenance.
- See our user manual for more information.



Guarantee

All of the materials we use are of high quality and have been modified for the purposes used.

As manufacturer, we guarantee:

- 5 year guarantee on all defects arising from normal use and maintenance.
- 7 year guarantee on the Fixscreen® technology*:
 - zip remains in side channel
 - optimal adhesion of zip to fabric

The warranty covers the delivery of replacement parts, assembly on site by an installer (possibly assisted by a technical employee from RENSON® Sunprotection-Screens) or a complete revision of the system by the manufacturer at our location. The assembly costs (travel + hourly rate) are not covered by this guarantee.

The guarantee period starts on the date of production and applies only to the product itself, and not to the installation of it.

The warranty can only apply if the product is used and maintained in accordance with the instructions contained in this manual. The guarantee lapses if the product is used incorrectly or abnormally.

When reporting a problem, please tell the installer the serial number.

* See our guarantee terms and conditions.

1 January 2005

EC Declaration of Conformity

Manufac RENSON® Sunprotection-Screens
IZ 1 Flanders Field
Kalkhoevestraat 45
B-8790 Waregem
Belgium

The undersigned,
Hereby declares that the product:

“Fixscreen®, Outdoor Sun Protection System” with CE certification:



RENSON® Sunprotection-Screens,
IZ 1 Flanders Field, Kalkhoevestraat 45,
Waregem, B-8790

Is compliant with annex ZA.1 of the European standard EN13561:2004

EN 13561
Blind for external use
Conform wind class 3

Paul Renson,

A handwritten signature in black ink, appearing to read 'P. Renson', written over a horizontal line.

Managing Director







Cherfan Draperies S.A.R.L., Jal El Dib Main Roan, P.O.Box 60-367 Beirut Lebanon

T + 961 4 710061 F + 961 4 719061 E info@creashade.com W www.creashade.com

Canada Branch: Creashade Canada Inc., 505 Industrial, Road Unit B2, Ottawa, Ontario K1G OZ1

T + 1 613 627 3959 M + 1 613 794 0097